

# We are Changing the Parameters

*Annual Report 2014 of H&R AG*

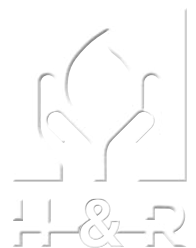

---

## Profile

As an internationally established specialist chemicals company, we process crude oil derivatives into high-quality products for a large variety of industries. With more than 1,550 employees, we generated €1.0 billion in sales revenues in 2014. In the years ahead we intend to further increase the value added by our refineries by means of targeted efficiency increase measures and continuous improvements in our processes. At the same time, we intend to expand internationally and to benefit from growth in the world's key economic regions.

## Our financial year 2014

During the financial year, we generated decent sales revenues of €1.0 billion. Nevertheless, the sudden drop in crude-oil prices at year-end prevented us from posting better operating earnings. Still, we accomplished a lot in 2014 and laid the groundwork for stabilizing and expanding the company internationally by integrating the Chinese businesses.

### T. 01 THE H&R GROUP IN FIGURES

IN € MILLION	2014	2013	Change in absolute terms
Sales revenue	1,058.6	1,214.4	-155.8
Operating result (EBITDA)	31.5	32.6	-1.1
EBIT	5.8	-4.1	9.9
Earnings before taxes	-7.8	-16.8	9.0
Consolidated earnings (before minority interests)	-15.6	-14.0	-1.6
Consolidated earnings (after minority interests)	-15.4	-14.0	-1.4
Consolidated earnings per share (undiluted, in €)	-0.49	-0.47	-0.02
Dividend per share (in €)	-	-	-
Operating cash flow	-0.4	88.9	-89.3
Equity ratio (in %)	35.2	31.8	3.4
Employees as of 31 December (absolute)	1,553	1,405	-148

### T. 02 THE SEGMENTS IN FIGURES

IN € MILLION	Revenue 2014	Revenue 2013	EBITDA 2014	EBITDA 2013
<b>Chemical and Pharmaceutical Raw Materials Refining</b> The ChemPharm Refining Segment produces speciality products from crude oil in the two domestic refineries in Hamburg and Salzbergen.	768.7	941.0	18.2	20.6
<b>Chemical-Pharmaceutical Raw Materials Sales</b> Our ChemPharm Sales Segment comprises the mixing and conversion plants abroad and our international sales activities.	244.7	231.7	18.8	16.5
<b>Plastics</b> Our Plastics Segment manufactures high-precision plastic parts along with the associated tools and moulds.	56.5	62.7	-1.5	0.7
<b>Transfer</b>	-11.3	-21.0	-3.9	-5.1

## Our sites

Together with our subsidiaries, we form a global conglomerate of refineries, speciality production plants and sales companies that meet customers' requirements for white oils, wax emulsions, paraffins, plasticisers and many other products.



### ○ CHEMICAL-PHARMACEUTICAL RAW MATERIALS

Hamburg/Salzbergen (Germany) // Laverton (Australia) // Tipton (Great Britain) // Mumbai (India) // Port Klang/Batu Caves (Malaysia) // Auckland (New Zealand) // Nuth (The Netherlands) // Singapore (Singapore) // Durban (South Africa) // Bangkok/Si Racha (Thailand) // Prague (Czech Republic) // Ningbo/Daixi/Fushun/Hong Kong (China)

### ○ PLASTICS

Coburg (Germany) // Wuxi (China) // Dačice (Czech Republic)

## Our business model

We take a product of crude oil distillation and apply intelligent processes to obtain more than 800 innovative, environmentally friendly and high-quality products such as plasticisers, white oils and paraffins. High-precision plastic parts complete our product portfolio. Our input material has an almost inexhaustible potential, and our products are an important building block in the processes and products of a great number of industries. These are excellent conditions that promise success also for the future.

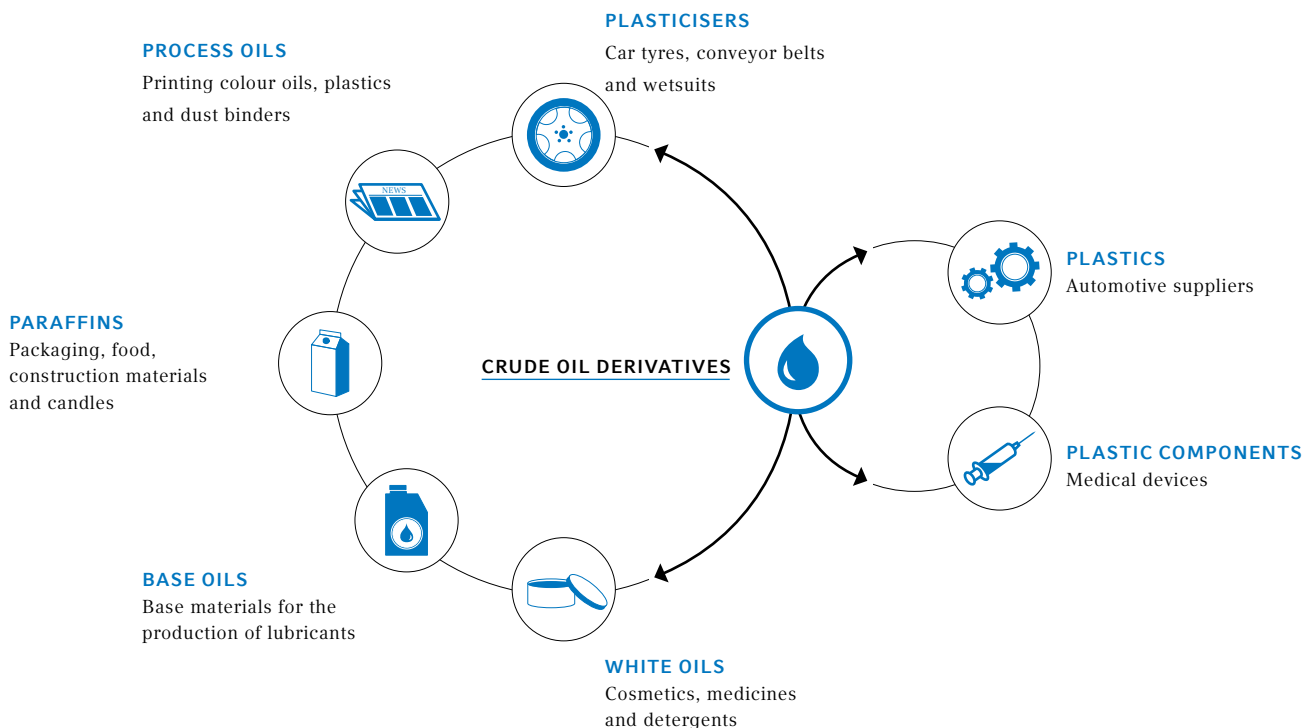

# We are Changing the Parameters

## Contents

<b>2 TO THE SHAREHOLDERS</b>	<b>44 GROUP MANAGEMENT REPORT<sup>2)</sup></b>	<b>96 CONSOLIDATED FINANCIAL STATEMENTS</b>	<b>158 ADDITIONAL INFORMATION</b>
4 Letter from the Executive Board	46 Group fundamentals	98 Consolidated balance sheet	160 Glossary
12 Company representative bodies	53 Financial report	100 Consolidated income statement	162 List of graphics and tables
14 We are Changing the Parameters	64 Non-financial performance indicators	101 Consolidated statement of comprehensive income	163 Six-year overview
24 Supervisory Board report	70 Earnings, financial and asset position of H&R AG	102 Consolidated statement of changes in shareholders' equity	164 Financial calendar
29 Corporate governance report <sup>1)</sup>	73 Other statutory disclosures	104 Consolidated cash flow statement	165 Contact details
40 H&R on the capital market	76 Key events following the balance sheet date	105 Notes	
	77 Forecast report	156 Attestation by the legal representatives	
	83 Risk report	157 Auditor's report	

<sup>1)</sup> Includes the remuneration report and the declaration on corporate governance in line with Art. 289a of the German Commercial Code (HGB), which both form part of the Group management report.

<sup>2)</sup> Combined management report for H&R AG and the H&R Group.

## Further information



Informative notes



Information on sustainability



Link to the H&R homepage



Useful information



***In 2014, the markets once again presented the company with challenges. But the H&R that emerged is more flexible, more stable and more diversified.***

*Financial year 2014 proved to be full of challenges for H&R AG. Geopolitical crises, the economic situation in the Eurozone, the fall in the price of crude oil at year-end, industry issues – business conditions were anything but ideal for H&R AG.*

*Nevertheless, during the past year, we focused and worked especially hard. For most of the year, we accomplished a great deal. Greater flexibility in managing raw materials positively affected our allocation ratio of primary products to by-products. The takeover of the important business activities in China will enhance our position in international business in the future and it gave us added stability at year-end 2014.*

## Key Topics in Financial Year 2014

- Significant increase in the percentage of primary products processed at our refineries
- Operating income on track for almost ten months, but full-year EBITDA nevertheless unsatisfactory due to the drop in the price of crude oil
- Integration of the Chinese businesses allows H&R AG to start the new financial year in a stronger position





## Dear Shareholders, dear Partners of H&R AG,

H&R AG focused and worked hard throughout the past financial year and accomplished a lot during most of the year.

As an economic region, Europe faced some major challenges right at the beginning of the year due to the geopolitical situation involving the trouble spot of Ukraine. The impact of the sanctions against Russia, the risk of rising energy prices and the discussion about the continuing crisis in the Eurozone were just three of the issues German companies had to deal with during the spring.

For us, in particular, additional industry concerns were added to the mix during the course of the year. Market conditions for lubricant refineries forced many operators in Western Europe to reduce capacity. However, this did not automatically lead directly to improved earnings at the remaining refineries – including H&R's refineries in Hamburg and Salzbergen. To an extent, producers in Eastern Europe competed for the remaining market share, thereby substantially increasing competitive pressure.

H&R AG had already made the conscious decision the previous year to avoid placing its hopes solely on a recovery of the global economy and its industry partners and instead to rely on its own efforts. This meant that the management of raw materials and energy took on special importance when the company was compelled to address the price war over by-products. By using more expensive, but at the same time higher-quality raw materials and by changing the way the Hamburg refinery operates, we positively affected our ratio of primary products to by-products for the long term.

In the third quarter in particular, we gained momentum with improved earnings, despite lower sales revenues. Although sales revenues were lower, this was attributable exclusively to the lower raw material prices, which as a component of material costs affected revenues; the order book and customer demand remained strong. At the same time, the fact that commodity purchases were cheaper overall, combined with a noticeable recovery in ICIS pricing for base oils from mid-year, had a positive impact on our results.

By integrating the Chinese specialty business of the Hansen & Rosenthal Group into H&R AG, we completed yet another ad-hoc project that has enabled us to systematically focus on our business model while enhancing our international presence.



Until shortly before the end of 2014, the company was therefore well on the way to achieving, and perhaps even surpassing, its earnings targets.

However, the rapid drop in the price of crude oil at year-end 2014 once again put pressure on H&R AG. As part of its refining process, the company buys raw materials that can only be utilized over the course of a production run that lasts several weeks. As a result of the sudden drop in price, high levels of inventories that had not yet been processed were bought at prices that were significantly more expensive than current market prices. The manufacturing costs of our primary and by-products are also largely driven by raw materials. Thus, also because of the length of the production run, products stored in the warehouses could have been produced with raw materials costing less than on the date when the production was scheduled.

All in all, this effect lowered operating income by around €-13.4 million in the fourth quarter of 2014, despite good sales figures and acceptable margins for the products already sold.

The Group's operating income (EBITDA) of €31.5 million for the entire year of 2014 was below the prior-year level. Sales revenues totaled €1.06 billion. Ultimately, though, H&R AG posted a consolidated net loss of €-15.4 million, a worse showing than in the previous year.

A look at the figures alone would therefore indicate that our performance in 2014 was worse than in 2013 and fell short of achieving a positive result, mainly due to the crude oil price situation. However, there are several good reasons for looking ahead with confidence:

The measures successfully implemented in previous years are a positive factor. They form the basis for a more stable corporate earnings trend. The conversion of the Salzbergen refinery to contract production and the resulting reduction in capital requirements has given us the room to maneuver and flexibility we need to efficiently manage raw materials. If the oil price stabilizes, this will eliminate the need for further revaluations on the inventory side.

Moreover, our company begins the new financial year in a significantly stronger position, both regionally and operationally. The new sites in Ningbo, Daixi, Fushun and Hong Kong enhance the position of H&R AG in the specialty-products business, which is enjoying strong growth internationally, and for the first time their sales revenues and earnings will be included in the Group's results for the entire year.

Finally, we will analyze further opportunities to optimize our organization in order to identify areas of overlap that may yield additional synergies for the H&R Group.



We would like to thank our customers, suppliers and investors for the excellent level of cooperation during the past year. We consider the constructive collaboration to be an excellent foundation on which we can all build to further expand our relationships over the long term.

We would also like to express our sincere gratitude to our employees. Their great commitment has made an important contribution to our joint efforts to further improve the efficiency of our organization. Thanks to their dedication, our company is an established global player in the market for crude-oil-based specialty products and high-precision plastic components.

In particular we thank you, our shareholders, for your trust in our shares. Your capital contribution provides the vital economic basis that empowers us to implement our strategy of sustainably increasing the enterprise value of H&R AG.

Together, we will gradually succeed in further stabilizing H&R AG and developing it so that it will once again generate positive, sustainable earnings in the years to come.

Best regards,

Your H&R AG Executive Board

Niels H. Hansen  
Chairman of the Executive Board

Detlev Wösten  
Member of the Executive Board

Wolfgang Hartwig  
Head of Finance

Salzbergen, March 2015





## Company representative bodies

*The representative bodies of H&R AG consist of personalities characterised by a combination of entrepreneurial thinking and professional competence. They complement one another by their individual skills, capabilities and varied expertise, which they contribute to the achievement of our common corporate goals.*

### Corporate Management

H&R AG's corporate management currently consists of three members. Each member of the Executive Board is responsible for one or more functions within the H&R Group.

#### Niels H. Hansen

Chairman of the Executive Board

#### Detlev Wösten

Member of the Executive Board  
Refineries, Production and Technology

#### Wolfgang Hartwig

Chief Financial Officer

### The Supervisory Board

The Supervisory Board of H&R AG is responsible for the appointment and supervision of the Executive Board as well as for the approval of significant corporate procedures. The Supervisory Board of H&R AG comprises the members set forth below. The Chairman of the Supervisory Board of H&R AG is Dr Joachim Girg.

#### Chairman of the Supervisory Board:

#### Dr Joachim Girg

Managing Director of H&R Beteiligung GmbH

#### Members of the Supervisory Board:

#### Roland Chmiel

Public Certified/Chartered Accountant,  
Partner in the law and accountancy firm  
Weiss Walter Fischer-Zernin

#### Nils Hansen

Personally liable member of the H&R Group

#### Anja Krusel

CFO, Microsoft Deutschland GmbH

#### Dr Eng. Hartmut Schütter

Consulting Engineer

#### Dr jur. Rolf Schwedhelm

Tax attorney and partner of the law firm  
Streck Mack Schwedhelm



## The Advisory Board

The Advisory Board of H&R AG consists of experts who contribute their expertise in the areas of finance and economics, industrial management and refinery technology on an advisory basis.

### Reinhold Grothus

Works Council Chairman of  
H&R ChemPharm GmbH

### Harald Januszewski

Thermoplast Work Preparation  
at GAUDLITZ GmbH

### Rainer Metzner

Sales Manager Medical Devices  
at GAUDLITZ GmbH

### Honorary Chairman of the Supervisory Board:

#### Bernd Günther

Honorary Chairman of the Supervisory Board  
of H&R AG since June of 2012.

### Harald Baumgart

Managing Director of KG Deutsche Gasrußwerke  
GmbH & Co

### Eckbert von Bohlen und Halbach

Managing Director of Bohlen Industrie GmbH

### Sabine Dietrich

Member of the Board of Directors of BP Europa SE

### Dr Eng. Bernd Drouven

Chairman of the Executive Board of Aurubis AG

### Dr Erwin Grandinger

Businessman

### Dr Bernd Pfaffenbach

Secretary of State in the German Federal  
Ministry of Economics and Technology, retired

### Wilhelm Scholten

Managing Director of Ölfabrik Wilhelm Scholten  
GmbH

### Dr Gertrud Rosa Traud

Chief Economist of  
Helaba Landesbank Hessen-Thüringen



# We are Changing the Parameters

*Markets are changing. And we are changing with them, to ensure that we will continue to be successful in the future. We are making adjustments at every level, refining our business model and optimizing the organizational structure. We are reworking our processes and improving our key performance indicators. Our focus on optimizing everything we do extends to our purchases of raw materials: here, too, we are changing the basic premises and requirements, so that at the end of the process we can deliver a level of quality that enables us to achieve the best possible market success.*

*Improved approach to managing raw materials*

**1:800**

---

*We extract more than 800 products from a single raw material. At the same time, we are constantly working on innovative process improvements that enable us to offer our customers not only products that satisfy their current specifications, but also specialty products with improved features and genuine added value. Our significantly improved approach to managing raw materials plays a decisive role in ensuring an optimal yield of high-value oil and wax specialty products: we analyze samples of raw materials virtually overnight, determining the “intrinsic value” and adjusting our refineries accordingly to respond to market conditions.*

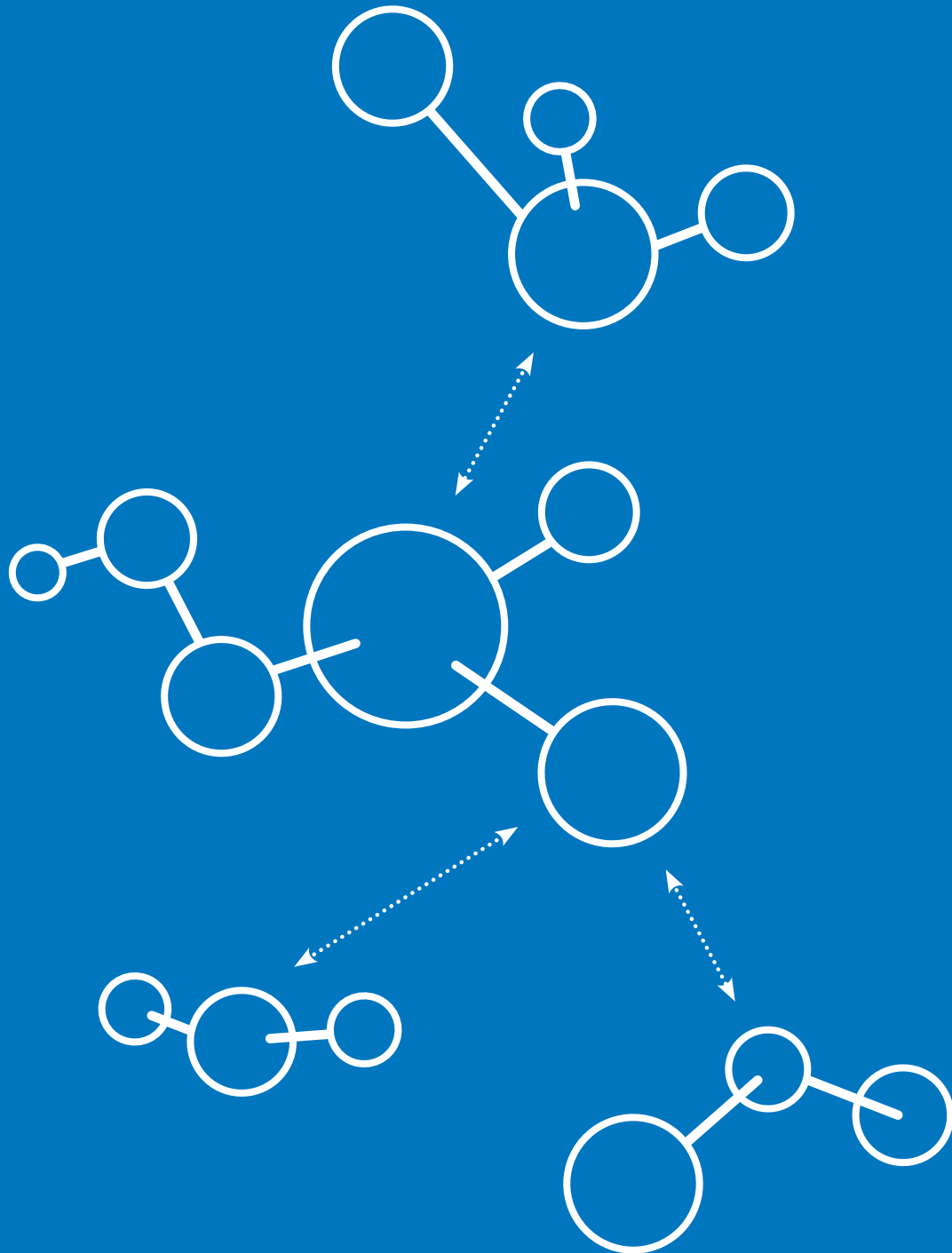

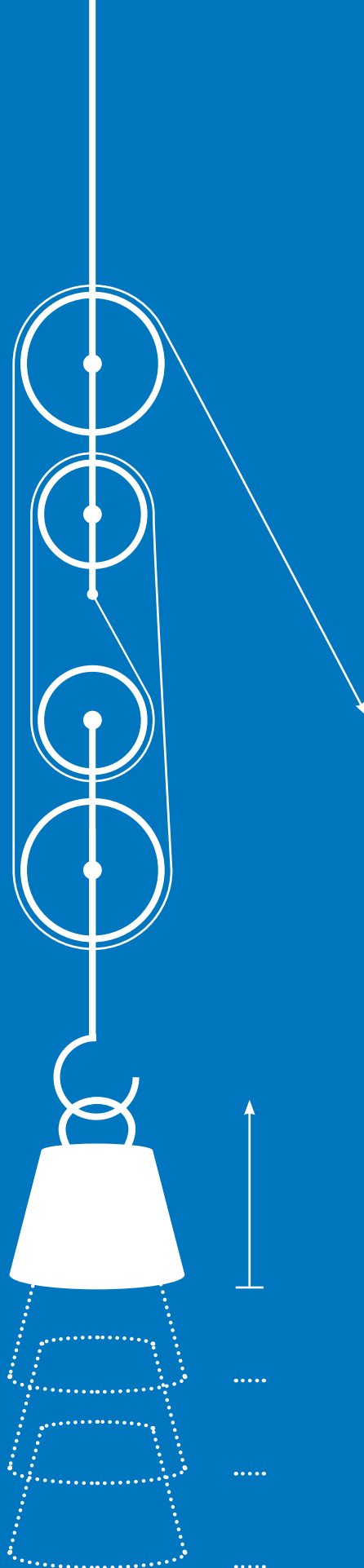

*Locations in China*

## ADDING FOUR TIMES THE POWER

---

*In 2014, we transferred 51% of the Hansen & Rosenthal Group's Chinese businesses to H&R AG. In the process, we gained the sites in Ningbo, Daixi, Fushun and Hong Kong. This has allowed us to improve our position in the high-growth international specialty-products business.*

*Decoupling from oil price volatility*

## MORE STABLE RESULTS

---

*In order to become less dependent on fluctuations in the oil price, we have revamped our business model in recent years and converted our Salzbergen refinery to contract production. By doing so, we are stabilizing the quality of our results, lowering our capital requirements and increasing our financial and economic flexibility.*



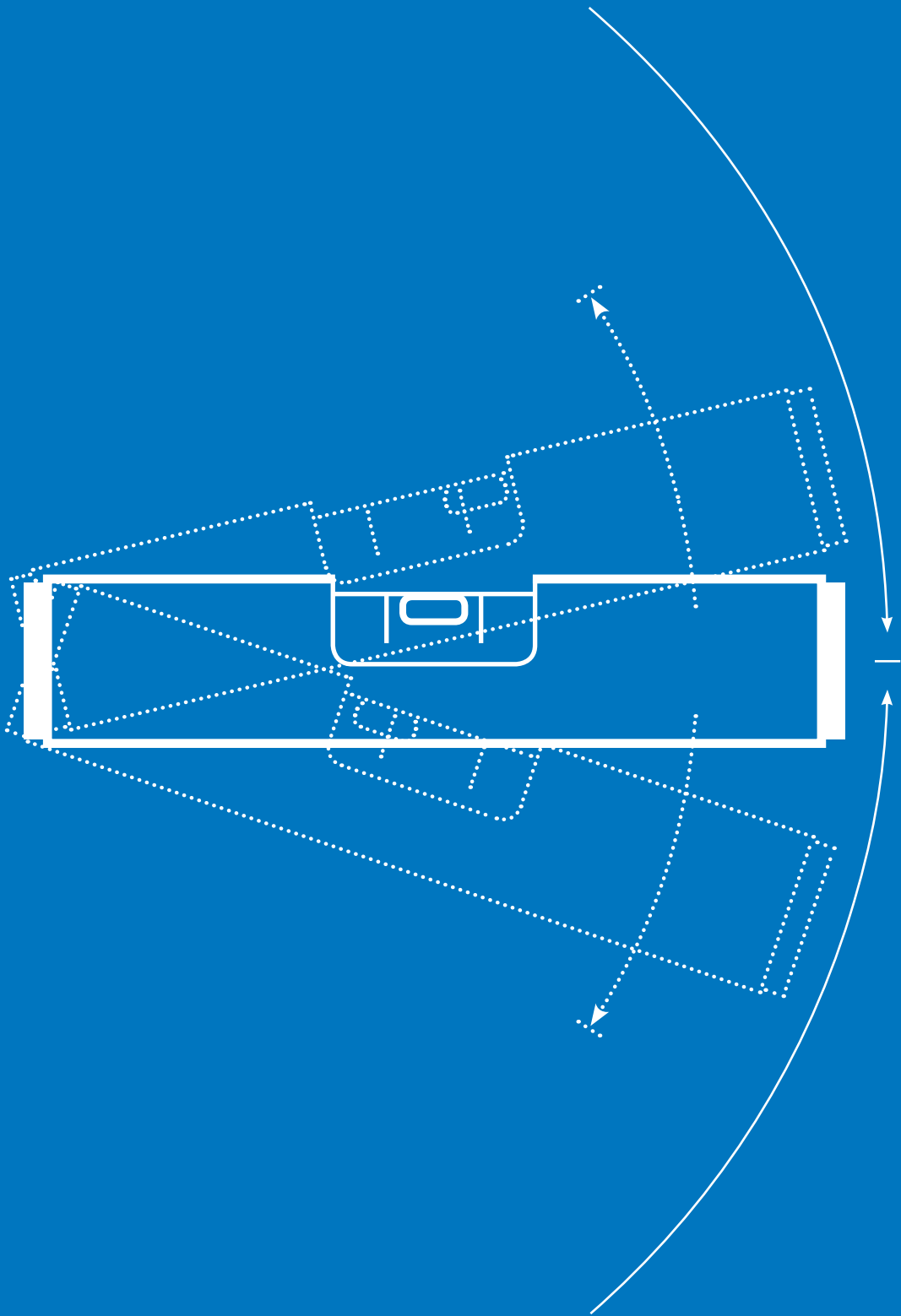

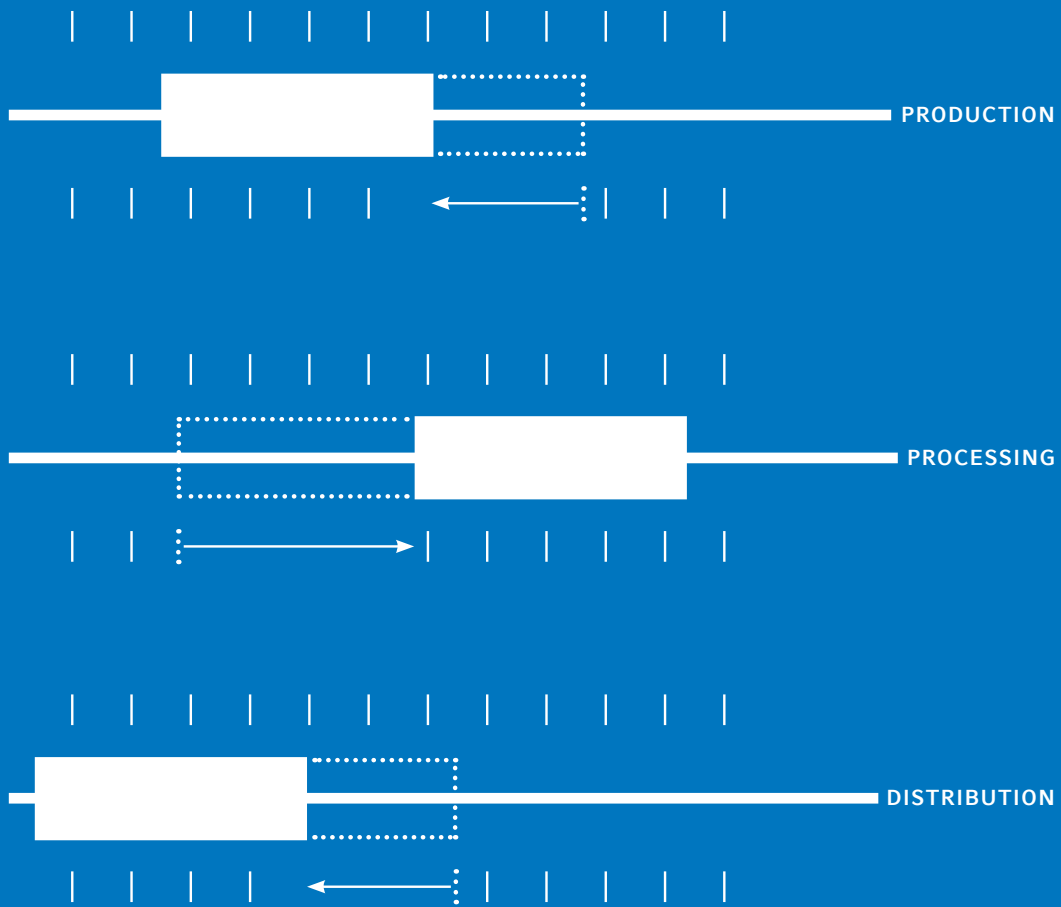

*Greater Flexibility*

## MORE ADDED VALUE

---

*Today, we have the flexibility to adapt to market conditions at every level of the value chain: as a refinery operator and producer, in further processing and in distribution. Whenever there is a need for external capacity beyond our in-house expertise, we can call on a network of efficient and high-performing partners.*

## Supervisory Board report

Dear Shareholders,

H&R AG once again faced a challenging year in 2014. The difficulties in the market environment for European lubricant refineries, which have persisted since the end of 2012, continued unabated – as evidenced by the numerous closings, or announced closings, of refineries.

If the main focus in 2013 was on quickly adapting H&R AG's financing needs to the new market conditions, the Executive Board and Supervisory Board concentrated on structural and strategic issues in 2014. The main result, and the one most evident to the outside world, of the structural and strategic project referred by the name "TIME" was the contribution of 51% of the Hansen & Rosenthal Group's Chinese businesses to H&R AG. Through this step, H&R AG brought the main international processing and marketing activities under the same umbrella as refinery production.

Consequently, at year-end 2014, H&R AG was better positioned and structurally more diversified than at the beginning of the year. Although some of the work in this regard is still ongoing, our earnings performance – until the drop in the crude-oil price shortly before the end of 2014 – confirmed that we are on the right path. The Supervisory Board and the Executive Board must and shall resolutely continue on this path, so that H&R AG can emerge stronger from the long-term changes taking place in the European refinery landscape. At the same time, we intend to provide new momentum that will once again make H&R's share an attractive investment for our shareholders in the foreseeable future.

**WORK OF THE EXECUTIVE BOARD AND THE SUPERVISORY BOARD.** The Supervisory Board diligently and conscientiously performed the supervisory and advisory duties required by law, the Articles of Association and internal rules of procedure.

During financial year 2014, the Supervisory Board and the Executive Board had a good, intensive working relationship. The Chairman of the Executive Board kept the Chairman of the Supervisory Board informed about all important issues on a regular basis and in a timely manner. Outside of

meetings, the Supervisory Board and the Executive Board also stayed in close contact in order to ensure a constant flow of information and an exchange of opinions.

An all-day training session for the Supervisory Board was held on 31 January 2014. The training course introduced and discussed Supervisory Board members' duties in light of current developments in legislation and case law. At its November meeting, after reviewing its own activities, the Supervisory Board did not identify any pressing need to improve its efficiency. The body has four independent members – a sufficient number of independent members.

There were no changes in the composition of the Executive Board or Supervisory Board in financial year 2014.

**WORK OF THE MEETINGS.** During 2014, a total of 8 Supervisory Board meetings and one teleconference were held. The attendance rate was 91%.

Pursuant to the obligations laid down in the internal rules of procedure, the Supervisory Board was regularly informed about the company's situation, both verbally and in writing. Aside from the TIME Project, special attention was paid to the developments at the refinery in Hamburg (Oelwerke Schindler – OWS) and to the Plastics segment that is part of GAUDLITZ GmbH. At each meeting, the Supervisory Board members also received information about the work of the committees. To the extent required by law or the Articles of Association, the Supervisory Board approved the proposed resolutions after thoroughly reviewing them.

At the meeting held on 18 February 2014, the Executive Board reported on the general business situation at the beginning of the year. In addition, two action plans were introduced and discussed. The first involved measures to sustainably improve and increase earnings at the Hamburg refinery; the second focused on the strategic development of GAUDLITZ GmbH. The Supervisory Board had particularly intensive deliberations regarding sup-

port for the measures in the first action plan. In preparation for the 2014 Annual Shareholders' Meeting, necessary amendments to the Articles of Association were discussed and adopted.

At the financial statements meeting held on 11 March 2014, the separate financial statements and the consolidated financial statements of H&R AG and the report on the company's ties to affiliated companies were audited, discussed and adopted in the presence of the auditors. At that meeting, the Supervisory Board also discussed and adopted the agenda for H&R AG's Annual Shareholders' Meeting and the Supervisory Board's report on financial year 2013. Moreover, the Supervisory Board received a status report on the TIME Project and discussed various options. As a further agenda item, a new internal reporting system was presented that also considers recommendations of the Supervisory Board.

At the meeting held on 12 May 2014, directly before the Annual Shareholders' Meeting, the Supervisory Board considered the current business situation and the status of preparations for the Annual Shareholders' Meeting. Other issues discussed included Executive Board matters and reports by the committees. The Executive Board was not present at the meeting.

The meeting held on 17 July 2014 focused on the TIME Project and in this regard, in particular, the presentation and discussion of the planned increase in capital through a contribution-in-kind, which in September 2014 ultimately led to the contribution of 51% of the Hansen & Rosenthal Group's Chinese businesses to H&R AG. This was followed by status reports on the ad-hoc projects involving OWS, GAUDLITZ and various sales/distribution issues, which were discussed in detail. Finally, the body debated how to proceed with the quartz sand reserves of the Sythengrund subsidiary in Haltern, which are owned by H&R AG.

The planned capital increase via a contribution-in-kind once again dominated discussions at the 28 August 2014 meeting. The Executive Board presented the current status of the Contribution Agreement, including its annexes, along with the current timetable for future actions. Another central issue was how to use or dispose of the re-

maining operations from the explosives division, which was sold back in 2007. The Executive Board reported on the planned sale of the quartz sand deposits at the former Sythengrund explosives production site to Quarzwerke GmbH and the sale of the marshlands to B.U.N.D. (the Association for the Environment and the Protection of Nature in Germany). The Supervisory Board was also notified that the lease agreement concluded with MAXAM Europe for continued use of the former production facilities should be renewed. The Supervisory Board approved these plans.

On 12 September 2014, the Supervisory Board dealt with the final documents concerning the contribution of 51% of the Hansen & Rosenthal Group's Chinese businesses to H&R AG. The Executive Board presented the necessary documentation in the presence of H&R AG's advisors. Particularly intense discussions were held on the Executive Board's report and the Contribution Agreement, the tax review of the transaction and the Fairness Opinion of the value of the property being contributed. Unanswered questions were sent back to the Executive Board for an answer by 17 September 2014. On that date, the Supervisory Board passed the necessary resolution on the contribution, plus the annexes – the Contribution Agreement, the Executive Board report and the Executive Board resolution – in a teleconference. The two dependent Supervisory Board members, Nils Hansen and Dr Joachim Girg, abstained.

At the 28 October 2014 meeting, the Executive Board reported on the company's business situation following the end of the third quarter. In addition, a progress report was provided on the separate financial statements for 2014 and the budget process for 2015. Additional agenda items included the status of preparation of the prospectus for admission of the shares issued as part of the increase in capital via a contribution-in-kind and other possible measures relating to the TIME Project.

The focus of the 25 November 2014 meeting was the 2015 budget. The Supervisory Board also worked on a revised version of the Statement of Compliance for 2014/2015. The Executive Board reported news about the compilation of the prospectus and the current status of the ad-hoc pro-

jects involving OWS and GAUDLITZ. At the same time, it provided an update on various sales/distribution issues. Finally, the Supervisory Board discussed the future structure of the Executive Board and, as recommended by the Steering Committee, renewed the agreements with Executive Board members Niels H. Hansen and Detlev Wösten and reappointed Mr Thierry Chevrier as Chief Operating Officer and Executive Board member from 1 January 2015.

**THE WORK OF THE SUPERVISORY BOARD COMMITTEES.** The Supervisory Board has established five committees: the Steering Committee, the Audit Committee, the Corporate Actions Committee, the Refinery Technology and Strategy Committee and the Nomination Committee. It is also empowered to set up ad-hoc committees. At subsequent Supervisory Board meetings, reports were given of the committees' work. All committee members attended the committee meetings. The composition of the committees is shown on page 35.

The Steering Committee helps the Supervisory Board to make personnel decisions. It held two meetings during the year under review. In making recommendations, the Steering Committee thoroughly discusses issues of diversity and the appropriate involvement of women in leadership positions. The committee also prepares decisions on remuneration issues for the Executive Board, the allocation of responsibilities, the conclusion of new Executive Board contracts and the renewal of existing ones.

The Audit Committee held four meetings during the reporting year. In the presence of the auditors and the Executive Board, it dealt with the financial statements and combined management report for H&R AG and the Group, the subordinate status report and the appropriation of net income. Further, the Audit Committee provided the Supervisory Board with a recommendation on the Supervisory Board's proposal for appointing a statutory auditor at the Annual Shareholders' Meeting. In addition, the following topics were discussed in detail: the issuance of the audit engagement to the auditors for financial year 2014, the monitoring of the auditors' independence and qualifications, as well as the additional work carried out by the auditors and the establishment of the auditing firm's

fees. At two further meetings, the Board worked intensively on the increase in capital via a contribution-in-kind of the Hansen & Rosenthal Group's Chinese business, the current situation and future prospects of the Plastics segment and sales/distribution agreements with the H&R Group. In addition, the Audit Committee examined the Group's accounting process, internal control system and risk management system and received reports on the results, work and audit plan of the internal audit function. In addition to the committee meetings, the Chairman of the Audit Committee, the auditors, the Executive Board and the Head of Finance held regular meetings to exchange information and coordinate their work.

The Corporate Actions Committee provides support to the Supervisory Board on corporate actions. Its responsibilities include negotiations on approval for corporate actions, obtaining expert opinions and issuing recommendations on resolutions to the Supervisory Board. The committee held two meetings during the reporting year. Because the same people serve on the Audit Committee and the Corporate Actions Committee, the latter also dealt with corporate action issues at its last two meetings. These are not reported separately.

The Committee for Refinery Technology and Strategy (RTS) met five times last year. The committee's work focused primarily on strategic issues, such as the optimal use of certain raw material qualities, the implementation of partner projects and the optimization of production results by converting what formerly were by-products into higher-quality products. Other important recurring themes involved security issues and facility availability, as well as the potential for expanding capacity. The committee's agenda in 2014 also included energy issues at the refinery sites.

The Nomination Committee – which nominates suitable Supervisory Board candidates to the Annual Shareholders' Meeting – did not meet during the year under review.

**T.03 COMPOSITION OF THE COMMITTEES**

Committee	Participants
Steering Committee	Supervisory Board: Dr Joachim Girg, Roland Chmiel, Nils Hansen, Reinhold Grothus
Audit Committee	Supervisory Board: Roland Chmiel, Dr Joachim Girg, Anja Krusel
Corporate Actions Committee	Supervisory Board: Dr Joachim Girg, Roland Chmiel, Anja Krusel
Refinery Technology and Strategy Committee	Supervisory Board: Dr Hartmut Schütter, Dr Joachim Girg, Nils Hansen
Nomination Committee	Supervisory Board: Nils Hansen, Dr Joachim Girg, Dr Rolf Schwedhelm

### Audit of the separate and consolidated financial statements

PricewaterhouseCoopers Aktiengesellschaft Wirtschaftsprüfungsgesellschaft, Hamburg, (PwC) audited the separate and consolidated financial statements and the combined management report for H&R AG and the Group for the financial year 2014 and issued an unqualified audit certificate for each. The separate financial statements for H&R AG and the combined management report for H&R AG and the Group were prepared in accordance with the requirements of the German Commercial Code (HGB).

The consolidated financial statements were prepared in accordance with International Financial Reporting Standards (IFRS) as applicable in the European Union (EU) and the supplementary provisions of German commercial law required by Article 315 (1) of the HGB. The auditor carried out the audit in accordance with Article 317 of the HGB and the generally accepted auditing principles promulgated by the Institute of Public Auditors in Germany (IDW). The Executive Board distributed the aforementioned documents to the Supervisory Board in good time. The separate and consolidated financial statements and the combined management report were also dealt with in depth at the Audit Committee meeting on 13 February 2015.

PwC's audit reports were distributed to all Supervisory Board members and were reviewed thoroughly in the presence of the auditors at the Supervisory Board meeting held on 20 February 2015 to discuss the financial statements. The auditors reported on the main findings of their audit and confirmed that the internal control and risk management system had no major weaknesses

as far as the accounting process was concerned. In addition, the auditors talked about significant transactions and decisions that had been taken concerning accounting policies. The Chairman of the Audit Committee gave an extensive report to the full Supervisory Board on the Audit Committee's review of the separate and consolidated financial statements.

At another meeting held via teleconference on 27 February 2015, the Supervisory Board again reviewed and discussed the separate financial statements, the consolidated financial statements and the combined management report. Based on the recommendation by the Audit Committee, we accepted the results of the audit conducted by the auditors and approved both the separate and the consolidated financial statements. The separate financial statements were thereby adopted. Because the separate financial statements did not report a distributable profit for the reporting year, the Executive Board did not present any proposal for the appropriation of net income to the Supervisory Board.

The report on relations with affiliated companies prepared by the Executive Board in accordance with Article 312 of the German Stock Corporation Act (AktG) was also examined by the auditors. The auditors informed the Supervisory Board of the outcome of the audit and issued the following auditors' opinion:

"Having carried out the audit and assessment in accordance with our professional duties, we confirm that

1. the factual information provided in the report is correct,

2. the payments made by the company for the legal transactions listed in the report were not inappropriately high,

3. there are no grounds for a significantly different assessment of the measures listed in the report to that made by the Executive Board.”

This report by the auditors was also reviewed by the Supervisory Board. The Supervisory Board endorses the closing statement made by the Executive Board in the report and has no objections to raise.

The Supervisory Board thanks the members of the Executive Board, all employees worldwide and the employee representatives for their hard work, their personal contributions and the constructive collaboration for the good of the company.

Signing for the Supervisory Board



Dr Joachim Girg  
Chairman

**T. 04 MEETINGS AND TELEPHONE CONFERENCES**

Date	Type	Focus	Relevant Resolutions
18 Feb. 2014	Meeting in Hamburg	– Business situation at beginning of year – Action plans for OWS and GAUDLITZ	– Amendments to Articles of Association regarding 2014 Annual Shareholders' Meeting
11 Mar. 2014	Meeting in Hamburg	– Meeting on the financial statements	– Adoption of 2013 separate financial statements
12 May 2014	Meeting in Hamburg	– Business performance – Executive Board issues	
17 July 2014	Meeting in Hamburg	– Presentation on and discussion of increase in capital via contribution-in-kind – Status reports on OWS and GAUDLITZ – Quartz sand reserves	
28 Aug. 2014	Meeting in Hamburg	– Increase in capital via contribution-in-kind – Use or disposal of quartz sand reserves – Use or disposal of Sythengrund subsidiary	– Approval of negotiations to sell Sythengrund
12 Sep. 2014	Meeting in Hamburg	– Increase in capital via contribution-in-kind, plus contractual bases and expert opinion	
17 Sep. 2014	Teleconference	– Increase in capital via contribution-in-kind	– Approval of the contribution, plus annexes (Contribution Agreement, Executive Board report, Executive Board resolution)
28 Oct. 2014	Meeting in Hamburg	– Business performance – Status of budget process – Progress report on separate financial statements and preparation of prospectus for the increase in capital via contribution-in-kind – Composition of Executive Board	
25 Nov. 2014	Meeting in Hamburg	– 2015 Budget – Progress report on prospectus – Status reports on OWS and GAUDLITZ – Sales/distribution issues – Composition of Executive Board	– Approval of 2014 budget – Executive Board agreements – Approval of Statement of Compliance



## Corporate Governance

### Declaration on Corporate Governance and Corporate Governance Report

Corporate governance refers to a company's decision-making and control processes. Good corporate governance means making decisions based on long-term value creation, ensuring that a company's Executive Board and Supervisory Board work together effectively, and demonstrating a high level of transparency in corporate communications. These factors are the key guiding principles when it comes to the management and supervision of H&R AG.

The Executive Board hereby issues the following Statement on Corporate Governance, in accordance with article 289a of the German Commercial Code (HGB), which is an integral part of the summarized Management Report, thereby also fulfilling Recommendation Number 3.10 of the current German Corporate Governance Code (Preparation of the Corporate Governance Report).

#### Updated Statement of Compliance 2015

The Executive Board and Supervisory Board issued the last Statement of Compliance pursuant to Article 161 of the German Stock Corporation Act (AktG) on 27 November 2014. The following updated statement refers to the recommendations of the Code as updated on 24 June 2014, which was published in the electronic version of the Federal Gazette (Bundesanzeiger) on 30 September 2014.

The Executive Board and Supervisory Board of H&R AG hereby declare that the recommendations of the Government Commission on the German Corporate Governance Code have been and are being complied with, with the following exceptions:

- Section 4.2.3, paragraph 2 of the Code: The variable remuneration components paid to Detlev Wösten, member of the Executive Board, are made up equally of the annual consolidated operating result (EBITDA), adjusted for any extraordinary result within the meaning of Article 275, paragraph 2, no. 16 of the German Commercial Code (HGB), and personal targets (so-called earnings component). Beginning with the

company's 2013 financial year, this is capped at 100% of the fixed annual remuneration. When this form of variable remuneration was selected, Detlev Wösten's position on the Executive Board was initially scheduled to terminate at the end of 2013.

In November 2014, this contract was renewed until the end of 2016 without any adjustments to the remuneration arrangement. Although a long-term basis theoretically exists for calculating the amount of variable remuneration over several years, it is not used to measure variable remuneration for two additional years; nor are possible negative developments taken into account. The Executive Board and the Supervisory Board are nonetheless certain that this form of variable remuneration sets no incentive that would be contrary to the company's sustainable development, since the variable remuneration components will be capped at 100% of the fixed annual remuneration from financial year 2013. If Mr Detlev Wösten's Executive Board appointment is renewed again after 2016, the Supervisory Board will once again review whether the variable remuneration should be adjusted to the Code recommendations in effect at that time.

- Section 5.1.2, paragraph 2 of the Code: Currently, only the executive employment contract with Mr Detlev Wösten stipulates a general age limit of 65. Neither the remaining executive employment contracts currently in force nor the rules of procedure for the Executive Board stipulate a general age limit for members of H&R AG's Executive Board. In view of the current age structure of the company's Executive Board, the Executive and Supervisory Boards to date have seen no reason for such a provision, because a formal age limit would unnecessarily complicate the search for suitable Executive Board members. However, the Supervisory Board intends to set a general age limit of 65 when concluding new executive employment contracts and in the event of any amendments to existing executive employment contracts.
- Section 5.4.6, paragraph 2 of the Code: The variable annual remuneration for Supervisory Board members according to Article 15, para-

graph 1 of the Articles of Association is linked to the return on capital employed (ROCE), which is calculated on the basis of the audited and approved consolidated financial statements by dividing earnings before interest and taxes (EBIT) by the interest-bearing capital (capital employed, i. e. the sum of net financial debt, equity and pension provisions). This variable remuneration for the financial year is not geared to sustainable business performance over a pe-

riod spanning several years, as Article 87, paragraph 1, sentences 2 and 3 of the German Stock Corporation Act (AktG) stipulate for Executive Board remuneration. The Executive Board and the Supervisory Board are currently deciding whether to propose to the Annual Shareholders' Meeting an adjustment to the Supervisory Board's variable remuneration in light of the new Code recommendations.

Salzbergen, 20 February 2014

Niels H. Hansen  
Chairman of the Executive Board

Detlev Wösten  
Member of the Executive Board

Dr Joachim Girg  
Chairman of the Supervisory Board

## Corporate Governance Report

In the following section, the Executive and Supervisory Boards report on Corporate Governance at H&R AG pursuant to Section 3.10 of the German Corporate Governance Code. The section also includes the Executive Board Remuneration Report.

**Corporate Governance Practices and Compliance**  
Management and control at H&R AG are based on the Articles of Association, the rules of procedure for the Supervisory Board and Executive Board, the German Corporate Governance Code and the relevant national legislation. Corporate management practices going above and beyond the statutory requirements are summarized in a Group-wide Code of Conduct. This Code defines binding rules of conduct derived from our corporate policy. Our values and the resulting corporate policy can be consulted online at [www.hur.com](http://www.hur.com) under the heading "About H&R". We work continuously to make our employees aware of the need to behave in accordance with the Code of Conduct when carrying out their jobs. We also hold extensive training sessions on special issues, depending on the area of responsibility. These courses at H&R focus on topics relating to occupational health and safety, environmental protection and anti-trust legislation.

Compliance infringements are systematically tracked and consistently subjected to disciplinary actions. Compliance with the requirements of the Group-wide Code of Conduct is regularly the subject of deliberations by the Supervisory Board.

### Shareholders and Annual Shareholders' Meeting

Our shareholders decide on company matters by exercising their voting rights at a General Shareholders' Meeting, which is held at least once a year. The shareholders entitled to attend and vote are those who on the 21st day before the Shareholders' Meeting (Record Date) hold H&R shares and correctly register to attend the Shareholders' Meeting. Each share entitles its holder to cast one vote (one-share-one-vote rule). Every shareholder who is entitled to vote has the option of exercising his voting right in person, appointing a proxy or abstaining from the vote. In addition, we offer shareholders the option to pool their votes

through our company's instruction-bound voting-rights representative.

Shareholders have the right to speak at the Annual Shareholders' Meeting, submit motions and request information about matters concerning the company and its affiliated companies insofar as is necessary to reach a constructive assessment of an item on the agenda. Our Annual Shareholders' Meeting elects six of the nine members of the Supervisory Board by rotation. Among other things, it also makes decisions on the appropriation of distributable profit, the formal approval of the activities of the Supervisory and Executive Boards, the appointment of the (Group) auditors, corporate actions and amendments to the Articles of Association. The invitation and all documents to be made accessible to the Annual Shareholders' Meeting are published on the H&R AG section of our website, [www.hur.com](http://www.hur.com), in a timely manner. After the Annual Shareholders' Meeting, the results of voting and attendance figures can also be found in this section of the website.

### Executive and Supervisory Board cooperation

In accordance with statutory requirements, we have implemented a dual management system with a strict separation between corporate management and control functions: The Executive Board manages the company independently and under its own responsibility. The Supervisory Board appoints, supervises and controls the Executive Board on the basis of rules of procedure for the Executive Board adopted by the Supervisory Board which, inter alia, regulate Executive Board reporting to the Supervisory Board. It is directly consulted and involved in decisions of fundamental importance for our company. Pursuant to Article 111, paragraph 4, sentence 2 AktG, the Supervisory Board has also issued to the Executive Board a list of transactions that require approval.

### Supervisory Board

In accordance with Article 8, paragraph 1 of the Articles of Association, in conjunction with Article 96, paragraph 1, alt. 4; Article 101, paragraph 1, sentence 1 AktG; in conjunction with Article 1, paragraph 1, sentence 1, no. 1; paragraph 2, sentence 1, no. 1, Article 4, paragraph 1 of the German One-Third Employee Participation Act (DrittelbG), our Supervisory Board is composed of



[www.hur.com](http://www.hur.com)

nine members in total, of whom six are appointed by the Annual Shareholders' Meeting, with no obligation to follow proposals made by the company, and three by the employees in accordance with the regulations on co-determination. The body is therefore subject to co-determination in accordance with the DrittelbG.

Dr Joachim Girg, Mr Nils Hansen and Ms Anja Krusel have been elected to the Supervisory Board as shareholder representatives for the period up to the close of the 2017 Annual Shareholders' Meeting, which will formally approve the activities of the members of the Supervisory Board for financial year 2016. Mr Sven Hansen was elected as a substitute member for Supervisory Board member Nils Hansen, on condition that he will become a member of the Supervisory Board if Mr Nils Hansen should leave the Supervisory Board before his regular term of office expires. The 2013 Annual Shareholders' Meeting elected Dr Hartmut Schütter to the Supervisory Board. His term of office will end at the close of the 2018 Annual Shareholders' Meeting. The term of office of the Supervisory Board members elected by the 2011 Annual Shareholders' Meeting, Mr Roland Chmiel and Dr Rolf Schwedhelm, will end at the close of the 2016 Annual Shareholders' Meeting. The Supervisory Board has been chaired by Dr Joachim Girg since his election to the Supervisory Board at the 2012 Annual Shareholders' Meeting.

The term of office of the three employee representatives on the Supervisory Board, Mr Reinhold Grothus, Mr Harald Januszewski and Mr Rainer Metzner, will also end at the close of the 2017 Annual Shareholders' Meeting.

The Supervisory Board oversees the Executive Board and advises its members on their management of the company. Executive Board members are appointed and dismissed by the Supervisory Board in line with Articles 84 and 85 of the German Stock Corporation Act (AktG) or, in exceptional cases, by the court. Amendments to the Articles of Association are made on the basis of Articles 133 and 179 AktG and Article 20, paragraph 2 of the Articles of Association. The Supervisory Board is nevertheless entitled to adopt amendments to the Articles of Association that

only affect their wording without the approval of the Annual Shareholders' Meeting. Article 13 of the Articles of Association defines further circumstances, in addition to those defined by statute, where the Supervisory Board's approval is required. Specifically, these are: entering into long-term liabilities, establishing and dissolving branch offices and establishing, liquidating, merging or converting subsidiaries. The Supervisory Board has also adopted rules of procedure as recommended in Section 5.1.3 of the German Corporate Governance Code.

Five committees have been formed from among its members:

- A Steering Committee chaired by Dr Joachim Girg; the other committee members are Mr Roland Chmiel, Mr Reinhold Grothus and Mr Nils Hansen. This committee is responsible for making preparations for the appointment of Executive Board members and carries out long-term succession planning. In addition, the committee is expected to propose resolutions regarding Executive Board remuneration to the Supervisory Board plenum.
- A Committee on Corporate Actions and Investments chaired by Dr Joachim Girg; the other committee members are Mr Roland Chmiel and Ms Anja Krusel. This committee prepares Supervisory Board votes on corporate actions.
- An Audit Committee chaired by Mr Roland Chmiel; the other committee members are Dr Joachim Girg and Ms Anja Krusel. As an auditor, Mr Chmiel has specialist knowledge and experience applying accounting principles and internal control procedures. This is a requirement for chairing this committee under Section 5.3.2 of the German Corporate Governance Code. Moreover, in the opinion of the Supervisory Board, he is qualified as an independent financial expert within the meaning of Article 100, paragraph 5 AktG. The Audit Committee's responsibilities include supervising the accounting process, monitoring the effectiveness of the risk management system and overseeing the audit of the financial statements, in addition to other responsibilities.

- A Nomination Committee chaired by Mr Nils Hansen; the other members are Dr Joachim Girg and Dr Rolf Schwedhelm. This committee's remit is to identify suitable Supervisory Board candidates who are then nominated by the Supervisory Board plenum at the Annual Shareholders' Meeting. Here, the committee is guided – apart from qualifications relating entirely to professional background – by the principle of diversity and it has set a target for women to occupy one-fifth of all positions on the Supervisory Board which are up for election.
- A Refinery Technology and Strategy Committee chaired by Dr Hartmut Schütter (since July 2013); the other committee members are Dr Joachim Girg and Nils Hansen. The Committee's purpose is to advise and supervise the Executive Board on the strategic future development of the H&R Group's refinery sites.

As individuals may not be members of the Executive Board and the Supervisory Board at the same time, the two management bodies have a high degree of independence. There are currently no former members of the Executive Board serving as members of the Supervisory Board.

To enable the members of the Supervisory Board to diligently prepare for meetings, the Executive Board informs them in advance of the topics to be addressed.

Pursuant to Section 5.4.1 of the Code, the Supervisory Board has set concrete objectives regarding its composition. These objectives are as follows:

- Maintain a share of women employees of at least 10% until the election of shareholder representatives in 2017; further increase the participation of women on the Supervisory Board at the next regular election of shareholder and employee representatives. The percentage of women shall reach at least 20%, with the proportion being uniform among both shareholders and employees.
- Maintain the composition of the Supervisory Board members with an international background at least at current levels.

- Consider special knowledge and experience applying accounting principles and internal control procedures.
- Consider technical expertise, particularly in the field of refining technology.
- Consider knowledge of the company.
- Independence of Supervisory Board members.
- Avoid conflicts of interest.
- Consider the age limit of 70 years at the time of the election.

With regard to the criterion of independence of the Supervisory Board members, the Supervisory Board plenum believes that, based on a Supervisory Board consisting of nine members, the number of independent board members should be at least six, taking into account the employee representatives. The Supervisory Board considers the employee representatives in connection with Annex II, Section 1 b) of the Commission Recommendation of 15 February 2005 on the role of non-executive directors/Supervisory Board members of listed companies and on the committees of the Management/Supervisory Board (OJ L 52, 25 February 2005, p.51) to be independent. By separate resolution of the shareholder representatives on the Supervisory Board, these have set the number of independent shareholder representatives to at least three.

The current composition of the Supervisory Board of H&R AG at present complies fully with the aforementioned specific objectives. From the perspective of the Supervisory Board, the Board includes four independent shareholder representatives, Ms Anja Krusel, Mr Roland Chmiel, Dr Rolf Schwedhelm and Dr Hartmut Schütter. Thus, taking into account the employee representatives on the Supervisory Board, the total number of independent Supervisory Board members is seven.

  
For further  
information  
see page 24–28

Further details concerning the work of the Supervisory Board during the reporting period can be found in the [Supervisory Board report](#) on pages 24 to 28 of this Annual Report.

#### Executive Board

The Executive Board manages the business of H&R AG independently and under its own responsibility, guided by statutory provisions, the Articles of Association and the resolutions adopted by the Annual Shareholders' Meeting. Its actions are always directed at generating a sustainable increase in the value of the company. In financial year 2014, the Executive Board on a continuous basis consisted of two people with the following responsibilities:

Niels H. Hansen,  
Chairman of the Executive Board:  
Corporate Strategy, Research & Technology,  
Capital Market Communications, Sales and  
Distribution Companies, International Business  
and IT

Detlev Wösten,  
Member of the Executive Board:  
Refineries, Production and Technology

On 25 November 2014, the Supervisory Board appointed Mr Thierry Chevrier as a member of the Executive Board, effective 1 January 2015. This Executive Board employment contract was rescinded by mutual agreement on 29 January 2015 to enable Mr Chevrier to assume new responsibilities at Hansen & Rosenthal KG.

  
For further  
information  
see page 83ff.

On the Executive Board, cooperation is regulated in detail by rules of procedures issued by the Supervisory Board. Each Board member is required, without first being asked, to inform the other Executive Board members of all significant events in the areas under his responsibility. The rules of procedure also stipulate circumstances which require a unanimous decision by the Executive Board plenum. As the Executive Board is relatively small, it has not formed any committees.

  
For further  
information  
see pages  
150 f.

#### Audit of the financial statements by PwC

Both the consolidated financial statements of H&R and the quarterly reports were prepared in accordance with International Financial Reporting Standards (IFRS). The separate financial statements for H&R AG were drawn up in accordance with the requirements of the German Commercial Code (HGB). The separate and consolidated financial statements of H&R AG for the 2014 financial year have been audited by PricewaterhouseCoopers AG Wirtschaftsprüfungsgesellschaft, Hamburg, (PwC) which has declared itself to be independent as required by Section 7.2.1 of the German Corporate Governance Code. It was agreed with PwC that the Supervisory Board Chairman would be notified immediately of any grounds for disqualification or conflicts of interest which may arise during the audit, unless these are resolved immediately. It was also agreed that the Supervisory Board would be notified immediately of any findings and events arising during the audit that are significant to the duties of the Supervisory Board. Finally, PwC is obliged to inform the Supervisory Board should any facts be identified during the audit which would render incorrect the Statement of Compliance issued by the Executive and Supervisory Boards in accordance with Article 161 of the German Stock Corporation Act (AktG).

#### Risk management

We have an early-warning system for risks that is reviewed by the auditor. For a detailed description of the system, please refer to the section of the [Management Report](#) entitled “Risk report”.

#### Avoiding conflicts of interest

There were no consulting or other service agreements or contracts between the Supervisory Board and the company during the year under review. There were no conflicts of interest of Executive or Supervisory Board members that had to be disclosed to the Supervisory Board without delay. Seats on supervisory boards and/or comparable German and foreign control bodies of business enterprises that had to be set up by law which are held by Executive Board and Supervisory Board members can be found on page 150 of this report in the section entitled “(41) Management bodies of the company”. Relations with related parties



are given in the [notes to the consolidated financial statements](#) beginning on page 105.

#### Deductible for D&O insurance

The company has taken out property damage liability insurance (D&O) for the members of the Executive Board and the Supervisory Board with an appropriate deductible in accordance with Article 93, section 2, sentence 3 AktG (Executive Board members) or in accordance with the German Corporate Governance Code (Supervisory Board members).

#### Shares held by members of the Supervisory Board and Executive Board

As of 31 December 2014, members of our Supervisory Board held a total of 21,598,429 shares and therefore an interest of considerably more than 1% of the share capital of H&R AG.

According to the last informal notification received from him, Mr Nils Hansen privately held a total of 344,279 H&R shares (0.96% of share capital) as of year-end 2014. In addition, another 15,405,213 H&R shares were attributable to Mr Hansen via H&R Holding GmbH (stake in

the share capital: 43.00%) and another 5,847,042 H&R shares were attributable to Mr Hansen via H&R Internationale Beteiligung GmbH (stake in the share capital: 16.32%).

Mr Nils Hansen therefore held a total of 21,596,534 H&R shares as of 31 December 2014, corresponding to 60.28% of the share capital.

As of 31 December 2014, members of our Executive Board held a total of 1,100 shares and therefore an interest of less than 1% of the share capital of H&R AG.

#### Directors' dealings

In accordance with Article 15a of the German Securities Trading Act (WpHG), management bodies and related individuals are obliged to disclose transactions involving H&R AG shares with a trading volume exceeding €5,000 in the course of a calendar year.

The regulation also includes financial instruments such as derivatives based on H&R shares. The following transactions have been reported to H&R AG for financial year 2014:



For further information see pages 105 f.

#### T.05 DIRECTORS' DEALINGS 2014

Date	Place	Name	Function	Denomination of the financial instrument	Type of transaction	Number	Price per unit	Transaction volume
10/1/2014	XETRA	Nils Hansen	Supervisory Board	H&R share	Purchase	2,000	8.99	17,980.00
12/3/2014	XETRA	Nils Hansen	Supervisory Board	H&R share	Purchase	2,000	7.69	15,380.00
25/4/2014	XETRA	Nils Hansen	Supervisory Board	H&R share	Purchase	5,000	7.24	36,185.00
13/5/2014	XETRA	Nils Hansen	Supervisory Board	H&R share	Purchase	10,000	7.85	78,506.00
14/8/2014	XETRA	Nils Hansen	Supervisory Board	H&R share	Purchase	10,000	6.90	69,013.00
15/8/2014	XETRA	Nils Hansen	Supervisory Board	H&R share	Purchase	10,000	6.84	68,447.00
25/9/2014	OTC	H&R Int. Op.	Related Parties	H&R share	Capital Increase	5,847,042	7.10	41,513,998
30/9/2014	XETRA	Nils Hansen	Supervisory Board	H&R share	Purchase	15,000	6.69	100,327.50
2/10/2014	XETRA	Nils Hansen	Supervisory Board	H&R share	Purchase	5,890	6.94	40,892.20
2/10/2014	Frankf.	Nils Hansen	Supervisory Board	H&R share	Purchase	2,000	6.99	13,984.00
7/10/2014	XETRA	Nils Hansen	Supervisory Board	H&R share	Purchase	10,000	6.70	67,047.50
16/10/2014	XETRA	Nils Hansen	Supervisory Board	H&R share	Purchase	6,000	6.68	40,107.00
27/10/2014	XETRA	Nils Hansen	Supervisory Board	H&R share	Purchase	10,000	6.79	67,875.00
29/10/2014	XETRA	Nils Hansen	Supervisory Board	H&R share	Purchase	10,000	6.78	67,849.00
4/11/2014	XETRA	Nils Hansen	Supervisory Board	H&R share	Purchase	5,000	6.93	34,637.00
5/11/2014	XETRA	Nils Hansen	Supervisory Board	H&R share	Purchase	5,000	7.33	36,645.00
6/11/2014	XETRA	Nils Hansen	Supervisory Board	H&R share	Purchase	5,000	7.45	37,268.00
11/11/2014	XETRA	Nils Hansen	Supervisory Board	H&R share	Purchase	5,000	7.53	37,658.50
27/11/2014	XETRA	Nils Hansen	Supervisory Board	H&R share	Purchase	10,000	7.99	79,868.00
11/12/2014	OTC	H&R Bet. GmbH	Related Parties	H&RAktie	Purchase	400,555	7.60	3,044,218
17/12/2014	Xetra	Nils Hansen	Supervisory Board	H&RAktie	Purchase	10,000	7.07	70,775

### Transparency

The prime objective of our communications is to provide comprehensive, prompt and equal information to shareholders, financial analysts, journalists, staff and interested members of the public.

For this purpose, important documents – such as quarterly and annual reports, ad-hoc statements and press releases, the Statement of Compliance with the German Corporate Governance Code, the Articles of Association, the invitation to the Annual Shareholders' Meeting and the financial calendar – are all published in the Investor Relations section of the H&R AG website. Interested parties can also register to receive the latest company news automatically via an e-mail newsletter. We also send out free copies of the reports upon request. The Executive Board and the Investor Relations team are in regular contact with both institutional and private investors at capital market conferences and shareholder events. For a detailed description of our capital market activities, please consult the section entitled “H&R on the capital market” on pages 40 to 43 of this Report).

  
For further  
information  
see page 40–43

## Remuneration Report

The following remuneration report is an integral part of the Management Report. It describes the system of remuneration for the Executive Board and the Supervisory Board at H&R AG.

### Remuneration of the Executive Board

The Executive Board of H&R AG consists of up to three members. The Supervisory Board plenum establishes and reviews the remuneration system for the Executive Board and the total remuneration paid to individual Executive Board members on the basis of discussions by the Personnel Committee. In accordance with the German Act on the Appropriate Remuneration of Executives (VorstAG), which came into effect on 5 August 2009, the Supervisory Board must ensure that the individual Executive Board members' total remuneration is commensurate with their responsibilities and performance. It must also be appropriate in the light of the company's position and should not exceed standard remuneration levels except in special cases. At publicly listed compa-

nies such as H&R AG, the remuneration structure must also be geared towards sustainable company performance.

Following these requirements, the total remuneration of the Directors of H&R AG consists of both non-performance-related and performance-related components. The non-performance-related portions consist of a fixed salary and benefits, while the performance-related components consist of a two-step variable remuneration with a sustainability component and an annual special or recognition bonus determined at the discretion of the Supervisory Board that is limited to a maximum of €100,000.

Special arrangements apply to the variable remuneration components paid to the deputy member of the Executive Board, Detlev Wösten, whose term of office was extended for another two years in 2014; his variable remuneration is derived in equal parts from the annual consolidated operating profit (EBITDA), adjusted by any extraordinary result within the meaning of Article 275, paragraph 2, no. 17 HGB, and from his personal targets.

The criteria for measurement of the Board members' remuneration include the economic situation, the company's performance and its future prospects. In addition, individual remuneration is dependent on the different duties of the members of the Executive Board and on their individual performance. The amount and structure of the remuneration paid to the Executive Board is reviewed regularly and adjusted as necessary by the Supervisory Board. To evaluate appropriateness, the Directors' remuneration is compared to that of other listed companies in similar industries of a similar size and complexity, as well as with the remuneration structure within the company itself. Moreover, it is also set at a level that ensures the company is in a position to compete for highly qualified top managers.

### Fixed remuneration

The fixed remuneration consists of a non-performance-related basic remuneration – which is paid pro-rata each month as a salary – plus various fringe benefits and non-monetary remuneration. At present, this primarily comprises insurance



premiums for private life and disability insurance policies; contributions to pension, health and long-term-care insurance policies corresponding to the amount payable by an employer if social insurance contributions were payable in full; and the private use of a company car. The Executive Board members pay tax on non-monetary remuneration based on the amounts reportable under tax guidelines.

The fixed salary is reviewed regularly (every two years).

#### Variable remuneration

The variable remuneration paid to Executive Board members, apart from Mr Detlev Wösten, is based on a hurdle system with a target range determined using the Group's operating income for the year (EBITDA) and certain long-term objectives for a rolling three-year period. In the case of Mr Niels H. Hansen, the maximum annual bonus is limited to 100% of the respective gross annual salary.

One-half of the variable remuneration consists of a component with a short-term incentive effect (referred to as the "earnings component") based on the annual operating group profit (EBITDA), adjusted by any extraordinary result within the meaning of Article 275, Section 2, No. 16 HGB, with the other half being a component with a long-term incentive effect (referred to as the "sustainability component").

The earnings component can be up to 50% of the annual target bonus and depends on whether the EBITDA defined in the business plan is achieved. If EBITDA is 110% or more of the plan, the Executive Board member is entitled to 100% of the earnings component (50% of the annual target bonus). The maximum entitlement to the earnings component is reduced on a straight-line basis by the percentage by which EBITDA is below plan. The sustainability component provides for a variable bonus based on the average return on capital employed (ROCE) over a rolling three-year period. The return is calculated as the ratio of EBIT to average capital employed (equity plus net financial debt, pension provisions and other non-current provisions). A maximum of 50% of the annual target bonus is paid if the average an-

nual ROCE reaches 20% or more. The maximum entitlement to the sustainability component is reduced pro-rata to 0% for a ROCE of up to 5%. By including this component, we satisfy the requirements of Article 87, paragraph 1, sentence 3 AktG, which stipulates that variable remuneration components must be calculated based on a time-frame spanning several years.

Should an Executive Board member's term of office end prematurely, any payments agreed for the departing Executive Board member – including fringe benefits – should not exceed the value of twice the annual salary (severance pay cap) or the value of the remuneration that would be payable for the remaining term of the executive employment contract. This is stipulated in Recommendation Number 4.2.3, paragraph 4 of the German Corporate Governance Code as amended on 24 June 2014. The company has followed this recommendation to the extent legally possible by including what are known as "coupling clauses" in executive employment contracts. These stipulate that, if the appointment is revoked, the Board member resigns for good cause or the Board position is otherwise terminated by the company, the employment contracts of Executive Board members will terminate two years after the term of office ends, but no later than the planned end of the appointment period.

The executive employment contracts of all Executive Board members ensure that the variable remuneration is limited in case of extraordinary developments in the company that could not have been foreseen at the time the executive employment contract was signed or at the time that targets were defined and which are deemed to render unreasonable for the company adherence to the payment of the agreed variable remuneration or to the defined targets. This could also be dealt with by appropriate adjustment of the targets already defined for the payment of variable remuneration. The company does not use securities-based incentive systems such as stock-option programs. No loans or advances were granted to members of the Executive Board.

**T. 06 EXECUTIVE BOARD REMUNERATION (GRANTED)**

Allocation granted	Niels H. Hansen				Detlev Wösten				Luis Rauch***	
	Chairman of the Executive Board				Member of the Executive Board – Refineries				Chief Financial Officer	
	Chairman of the Executive Board since 1 January 2012				Member of the Executive Board since 1 August 2011				Member of the Executive Board 1 January 2012 to 31 August 2013	
IN €	2013	2014	2014 (Min)	2014 (Max)	2013	2014	2014 (Min)	2014 (Max)	2013	2014
Fixed remuneration*	284,702*	356,747	356,747	356,747	194,077*	231,747	231,747	231,747	294,933*	–
Fringe benefits**	251	251	251	251	14,741	16,478	16,478	16,478	337,770	–
<b>Total</b>	<b>284,953</b>	<b>356,998</b>	<b>356,998</b>	<b>356,998</b>	<b>208,818</b>	<b>248,226</b>	<b>248,226</b>	<b>248,226</b>	<b>632,703</b>	<b>–</b>
One-year variable remuneration	74,375	92,750	–	356,747	126,500	141,750	–	231,747	75,000	–
Multiple-year variable remuneration	–	–	–	–	–	–	–	–	–	–
Plan name (Plan term)	–	–	–	–	–	–	–	–	–	–
<b>Total</b>	<b>359,328</b>	<b>449,748</b>	<b>356,998</b>	<b>713,745</b>	<b>335,318</b>	<b>389,976</b>	<b>248,226</b>	<b>479,973</b>	<b>707,703</b>	<b>–</b>
Pension expenses	–	–	–	–	–	–	–	–	–	–
<b>Total compensation</b>	<b>359,328</b>	<b>449,748</b>	<b>356,998</b>	<b>713,745</b>	<b>335,318</b>	<b>389,976</b>	<b>248,226</b>	<b>479,973</b>	<b>707,703</b>	<b>–</b>

\* Pursuant to the resolution of the meeting of the Supervisory Board held on 22 August 2013, the Executive Board waived 15% of its fixed remuneration for the months from August up to and including December 2013.

\*\* Inter alia, this item includes the use of a car and accident-insurance premiums

\*\*\* Due to the departure during 2013 of Executive Board member Luis Rauch, the amounts granted and received for 2013 are identical.

**T. 07 EXECUTIVE BOARD REMUNERATION (ACCRUED)**

Accrual	Niels H. Hansen		Detlev Wösten		Luis Rauch***	
	Chairman of the Executive Board		Member of the Executive Board – Refineries		Chief Financial Officer	
	Chairman of the Executive Board since 1 January 2012		Member of the Executive Board since 1 August 2011		Member of the Executive Board 1 January 2012 to 31 August 2013	
IN €	2013	2014	2013	2014	2013	2014
Fixed remuneration	284,702*	356,747	194,077*	231,747	294,933*	–
Fringe benefits	251	251	14,741	16,478	337,770	–
<b>Total</b>	<b>284,953</b>	<b>356,998</b>	<b>208,818</b>	<b>248,226</b>	<b>632,703</b>	<b>–</b>
One-year variable remuneration	80,763	74,375	43,601	126,500	75,000	–
Multiple-year variable remuneration	–	–	–	–	–	–
Plan name (Plan term)	–	–	–	–	–	–
Other	–	–	–	–	–	–
<b>Total</b>	<b>365,716</b>	<b>431,373</b>	<b>252,419</b>	<b>374,726</b>	<b>707,703</b>	<b>–</b>
Pension expenses	–	–	–	–	–	–
<b>Total remuneration</b>	<b>365,716</b>	<b>431,373</b>	<b>252,419</b>	<b>374,726</b>	<b>707,703</b>	<b>–</b>

### Supervisory Board remuneration

Supervisory Board remuneration is governed by Article 15 of our Articles of Association and primarily comprises the following elements:

Every member of the Supervisory Board receives a fixed annual payment of €20,000.00 in addition to the reimbursement of out-of-pocket expenses. The Chairman of the Supervisory Board receives three times and his deputy one and a half times this amount. In addition to this, every member of the Supervisory Board receives variable annual remuneration linked to the return on capital employed (ROCE), which is calculated on the basis of the audited and approved consolidated financial statements for the respective financial year. The return is calculated by dividing earnings before interest and taxes (EBIT) by the interest-bearing capital (capital employed, i. e. the sum of net financial debt, equity, pension provisions and non-current provisions). A minimum return of 10% must be achieved in order for variable remuneration to be paid. If the minimum return is achieved, €10,000.00 is paid to each Supervisory Board member per financial year. For each

percentage point over the 10% minimum return, the variable remuneration increases by €1,500.00 for each Supervisory Board member per financial year. The variable remuneration is limited to a total of €32,500.00 per Supervisory Board member and financial year.

Supervisory Board members who belong to one of the Supervisory Board's committees receive an additional 1/8 of the fixed annual remuneration per committee. Members of the company's Audit Committee receive 1/4 of the fixed annual remuneration. Supervisory Board members who chair one of the committees receive twice the remuneration payable for membership of the committee in question. The members of the Supervisory Board receive an attendance fee of €200.00 for each Supervisory Board or committee meeting they attend.

The fees paid in 2014 under a consulting contract with the company controlled by the former Chairman of the Supervisory Board, Mr Bernd Günther, i.e. Idunahall Verwaltungs-Gesellschaft m.b.H., amounted to €102,000 (prior year: €75,000).

#### T.08 SUPERVISORY BOARD REMUNERATION

IN €	Fixed remuneration*		Remuneration for Supervisory Board activities		Variable remuneration		Total	
	2014	2013	2014	2013	2014	2013	2014	2013
Dr Joachim Girg (Chairman)	60,000	56,250	20,000	20,000	–	–	80,000	76,250
Roland Chmiel	30,000	28,125	15,000	15,000	–	–	45,000	43,125
Anja Krusel	20,000	18,750	7,500	7,500	–	–	27,500	26,250
Dr Rolf Schwedhelm	20,000	18,750	2,500	2,500	–	–	22,500	21,250
Nils Hansen	20,000	18,750	10,000	10,000	–	–	30,000	28,750
Dr Hartmut Schütter (from 23/7/2013 onwards)	20,000	7,572	5,000	1,555	–	–	25,000	9,127
Reinhold Grothus	20,000	18,750	2,500	2,500	–	–	22,500	21,250
Harald Januszewski	20,000	18,750	–	–	–	–	20,000	21,250
Rainer Metzner	20,000	18,750	–	–	–	–	20,000	18,750
<b>Total</b>	<b>230,000</b>	<b>204,447</b>	<b>62,500</b>	<b>59,055</b>	<b>–</b>	<b>–</b>	<b>292,500</b>	<b>263,502</b>

\* Pursuant to the resolution of the meeting of the Supervisory Board held on 22 August 2013, the Executive Board waived 15% of its fixed remuneration for the months from August up to and including December 2013.

## H&R on the capital market

### Company share and share price performance

**SHARES WITHSTAND GLOBAL CRISES IN 2014.**  
The global equity markets came under pressure from many directions in 2014:

Economic problems were just as challenging as political issues such as the conflict in Ukraine and advances by the so-called Islamic State in Iraq and Syria. The rapid year-end drop in the price of oil, the smoldering European debt crisis and the expiration of the U.S. Federal Reserve's quantitative easing programs created plenty of challenges for the equity markets. Stock markets were bolstered by the European Central Bank's monetary policy, low commodity prices and the rebound in technology stocks. Whereas many had already predicted an end to China's growth, the country's economic performance was unexpectedly stable.

Against this backdrop, share indices were quite volatile in 2014. Over the year as a whole, the leading DAX index hardly advanced at all. The situation was similar on the MDAX and SDAX stock market segments, where the year-end value was only slightly above or below the level at the

beginning of the year. In view of the many uncertainties and trouble spots, this is a respectable performance for German equity investors.

**H&R SHARE PERFORMED BELOW EXPECTATIONS.**  
Following a moderate start to the year and a brief recovery to over €9.00, the shares fell to below €8.00 when the 2013 Annual Report was published. Over the following months, the price mainly trended sideways, declining slightly in the autumn. The share recovered considerably following publication of the positive figures for the third quarter of 2014, but once again came under pressure following the company's press release about the trend in crude-oil prices.

Having started financial year 2014 at an opening price of €8.77, H&R's shares ended the reporting period at a closing price of €7.54 on 30 December. By year-end, our share therefore had recovered significantly from its 2014 low of €6.45.

#### G. 01 PERFORMANCE OF THE H&R SHARE

(INDEX 2/1/2014=100)

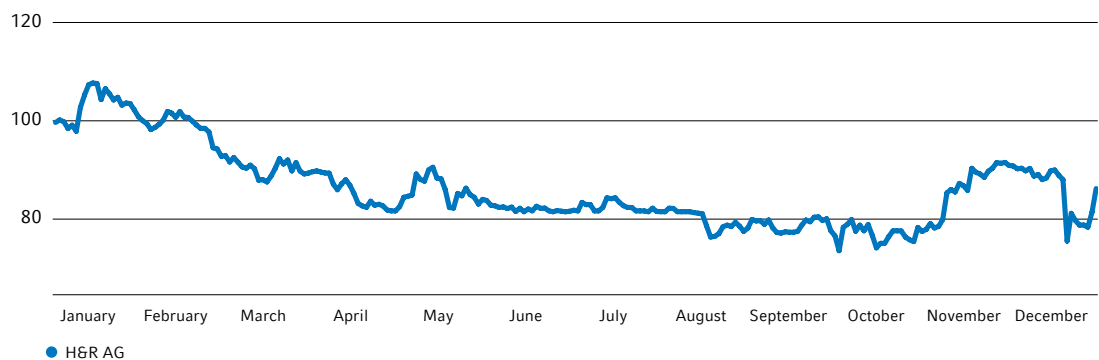

**T. 09 BASIC DATA ON THE H&R SHARE**

ISIN/WKN	DE0007757007 / 757007
Abbreviation	2HR
Type	No-par bearer shares
Listings	Official market Frankfurt (Prime Standard), Hamburg and Düsseldorf, freely traded Stuttgart and Munich
Index	Prime Standard All Share, Classic All Share, Prime Chemicals and Prime IG Chemicals Speciality, DAXPlus Family-Index
Designated Sponsor	Close Brothers Seydler Bank AG

NUMBER OF SHARES, MARKET CAPITALIZATION AND TRADING VOLUME. The number of company shares issued totaled 35,820,154 on 31 December 2014. A total of 5,847,042 new shares were added as a result of the use of approved capital on 17 September 2014. Until they have been admitted for listing, these newly issued shares cannot be traded on the stock exchange. Nevertheless, they increased our company's notional market capitalization to €270.1 million (31 December 2013: €260.7 million).

Although H&R's share satisfied the stock exchange's criteria for membership of the SDAX in terms of market capitalization and stock-ex-

change trading, the Management Board of Deutsche Börse AG followed the recommendation of the Working Committee on Equity Indices and removed H&R AG's shares from the SDAX effective 24 March 2014. Instead, as part of a reassessment of the index's composition, companies were included in the index which, due to various corporate actions, have a greater level of free float and therefore, based on the stock exchange's definition, show a higher market capitalization.

As a company in the Prime Standard segment, H&R AG continues to meet all important disclosure and transparency standards. The share price can be obtained from the trading systems and the financial press. A total of around 4.6 million shares with a total volume of almost €38.0 million were traded on the Frankfurt Stock Exchange and on Xetra.

**G. 02 HIGHEST AND LOWEST PRICES OF THE H&R SHARE, FULL YEAR 2014**

IN €

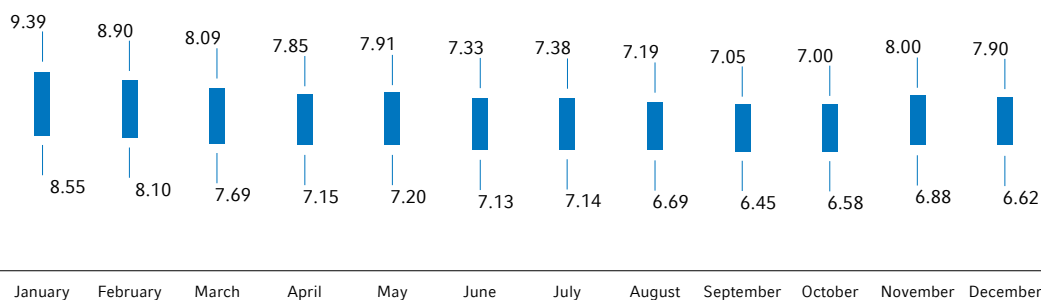

● Highest and lowest price

T. 10 KEY SHARE DATA

	2014	2013	2012	2011	2010
Number of shares on 31 December	35,820,154	29,973,112	29,973,112	29,973,112	29,973,112
Earnings per share		€-0.47	€0.02	€1.29	€1.74
Highest price for the year	€9.40	€13.03	€17.90	€21.86	€22.89
Lowest price for the year	€6.45	€8.05	€11.57	€12.98	€13.20
Price on 31 December	€7.54	€8.70	€11.83	€16.55	€21.05
Performance (excluding dividend)	-19.2%	-28.1%	-28.2%	-21.4%	40.5%
Market capitalization on 31 December	€270.1 million	€260.7 million	€354.4 million	€496.1 million	€630.9 million
Dividend	-	-	-	€0.60	€0.65
Dividend yield	-	-	-	3.6%	3.1%
Average daily trading volume	€130 thousand	€324 thousand	€522 thousand	€575 thousand	€666 thousand

BOARD MEMBERS ONCE AGAIN INCREASE STAKE IN H&R AG. In the reporting period we received notice of 21 directors' dealings in H&R shares.

The Supervisory Board member Nils Hansen increased his personal holdings of H&R shares in 19 steps by a total of 137,890 shares. Companies whose stake in H&R AG is attributable to Mr Nils Hansen (H&R Beteiligung GmbH: 400,555 shares; H&R Internationale Beteiligung GmbH: 5,847,042 shares) also increased their holdings. The individual transactions are listed in the "Directors' dealings" section on page 35 of this report.

SHAREHOLDER STRUCTURE. According to the notification from Mr Nils Hansen dated 26 September 2014, his share of voting rights, held by H&R Beteiligung GmbH and attributable to Mr Nils Hansen via H&R Holding GmbH, was 41.89% on 25 September 2014 and therefore was below the 50% threshold on that date.

According to an informal notification on 11 December 2014, H&R Beteiligung GmbH's stake rose by another 1.11%.

G. 03 SHAREHOLDER STRUCTURE AS OF 31/12/2014

IN % (VALUES AT THE END OF THE PREVIOUS YEAR)

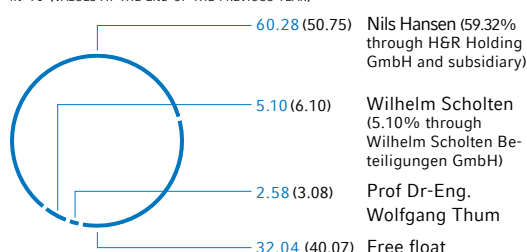

According to another notification from Mr Nils Hansen dated 26 September 2014, his share of voting rights, held by H&R Internationale Beteiligung GmbH and likewise attributable to Mr Nils Hansen, exceeded the 15% threshold on 25 September 2014 and amounted to 16.32% on that date.

According to the last informal notification received from Mr Nils Hansen, he personally held an additional 0.96% of the outstanding H&R shares as of year-end 2013.

According to a notification on 2 April 2003 pursuant to the German Securities Trading Act (WpHG), on 28 March 2003, Mr Wilhelm Scholten held 6.65% of the voting rights via the company Wilhelm Scholten Beteiligungen GmbH, which is attributable to him. Following the dilution of voting rights caused by the conversion of preferred shares into ordinary shares in 2008, this corresponded to a notional stake of 6.08%. The increase in capital resulting from the use of approved capital diluted Mr Wilhelm Scholten's share of voting rights on 25 September 2014 to 5.10%. According to an informal notification, this share was unchanged on 31 December 2014.

According to a voting-rights notification dated 26 September 2014, Prof. Dr-Eng. Wolfgang Thum held more than 2.58% of the voting rights in H&R AG on 25 September 2014. According to an informal notification, this also was equal to his share of voting rights at year-end 2014.

The remaining 32.04% of H&R shares were in free float as of 31 December 2014.



For further information see page 35

## Investor Relations

PURPOSEFUL COMMUNICATION WITH THE CAPITAL MARKET. During the 2014 reporting year, investors, analysts and private investors increasingly took advantage of the opportunity to exchange information with the company by telephone or e-mail. In addition, numerous investors visited us at our production sites in Hamburg and Salzbergen in order to see our refineries firsthand and to discuss current company developments directly with the Executive Board.

Members of the management team and employees of the IR department also represented the company at roadshows and at information events. Our quarterly reports and other important announcements were accompanied by teleconferences with our analysts. In financial year 2015, H&R AG once again plans to increase its presence significantly over 2013-14.

RESEARCH COVERAGE CONTINUES TO BE OF THE HIGHEST QUALITY. During the reporting period, the number of banks covering H&R shares has decreased. This is mainly due to adjustments on the part of the analyst firms; some of them have gone out of business while others merged their research departments over the course of the year. Overall, analysts from seven banks wrote research reports on H&R shares and informed investors with regular updates.

### T. 11 RESEARCH COVERAGE OF THE H&R SHARE

---

Bankhaus Lampe

---

Kepler Chevreux

---

Close Brothers Seydler (new in 2012)

---

Commerzbank

---

Baader Bank

---

NordLB

---

WE WOULD LIKE TO HEAR FROM YOU. Our company reports can be downloaded from the H&R AG section of our website, [www.hur.com](http://www.hur.com). We will be happy to send you a printed copy on request. We would also be glad to keep you up to date with the latest developments at the company via our e-mail newsletter. You can register for these publications in the Investor Relations section of our website.



[www.hur.com](http://www.hur.com)

Should you have any questions or comments, please contact us as follows:

H&R AG  
Investor Relations  
Am Sandtorkai 50  
20457 Hamburg  
Germany  
Phone: +49 (0) 40-43 218-321  
Fax: +49 (0) 40-43 218-390  
Email: [investor.relations@hur.com](mailto:investor.relations@hur.com)  
Internet: [www.hur.com](http://www.hur.com)





## *Key topics in 2014*

- By flexibly switching our raw-material input in response to the price war over by-products, we increased the percentage share of primary products
- Steady recovery in EBITDA from beginning of the year into the fourth quarter of 2014 is slowed by drop in the price of crude oil
- Negative effects totaled approximately EUR -13.4 million in the fourth quarter of 2014 alone (full year: EUR -16.1 million)
- Successful completion of an increase in capital through a contribution-in-kind and inclusion of the Hansen & Rosenthal Group's Chinese businesses

## Group fundamentals

### Group business model and structure

#### Sectors and organisational structure

The H&R Group organizes its operating activities into two business divisions: the large Chemical-Pharmaceutical Division and the smaller Plastics Division.

At the same time, we have three operating segments: the Chemical-Pharmaceutical Raw Materials/ChemPharm Refining segment (formerly the “Domestic” segment), the Chemical-Pharmaceutical Raw Materials/ChemPharm Sales segment (formerly the “International” segment) and the Plastics segment.

Our biggest segment (percentage of sales in 2014: 71.6%), ChemPharm Refining, includes the refineries in Hamburg-Neuhof and Salzbergen. The main products that we manufacture at these plants are crude-oil-based specialty products such as plasticizers, paraffins, white oils and base oils. Over 800 different products are created in the course of our production processes. They are used in more than 100 client industries.

 For further information see the glossary on page 160 f.

 For further information see page 105

Our ChemPharm Sales segment (percentage of total sales in 2014: 23.1%) combines numerous blending, further processing, filling and tank-farm facilities and distribution sites worldwide. The segment's main products include label-free plasticizers for the tire industry and wax emulsions for the building-materials industry.

The Plastics Division (percentage of sales in 2014: 5.3%) combines the high-precision plastic parts business with production of the molds required to manufacture them. In addition to the headquarters in Coburg, we also operate production sites in Eastern Europe and Asia. The Plastics Division's main customer is the automotive industry; in addition, we produce specialty plastic parts for the medical technology industry and other industries.

Because of our former explosives business, H&R AG owns land with quartz sand mining potential in Haltern am See. Potential options for using or disposing of the property are being reviewed or

have already been implemented (the sale of a portion of the property on 1 January 2015).

#### Group's legal structure

As the Group's holding company, H&R AG is in charge of the strategic management of our business operations. It is responsible for communicating with the public and the capital markets, and for the Group's financing. In addition, various management functions and services are provided centrally for our subsidiaries.

At the end of the reporting period, there were 34 consolidated subsidiaries (at 31 December 2013: 29); thanks to the inclusion of 51% of the business activities of the Hansen & Rosenthal Group in China under the umbrella of H&R AG, the following companies have now been added to the consolidated group in addition to H&R China Holding GmbH: H&R China (Ningbo) Co. Ltd., H&R China (Daixi) Co. Ltd., H&R China (Fushun) Co. Ltd. and H&R China (Hong Kong) Co. Ltd.

Our subsidiaries can be found in the list of shareholdings in the Group Notes under “(5) Holdings and Scope of Consolidation”.

The renaming and organization of the individual segments reflects the regional distribution of the sites and the circumstances specific to the different industries. Thus the ChemPharm Refining segment, the core of which is formed by the refineries in Hamburg and Salzbergen, uses a functional management structure owing to the similarity and regional proximity of the production sites. Managerial staff within this segment have cross-site responsibility for key functions such as raw materials purchasing, project management, accounting and sales/distribution.

In the ChemPharm Sales segment, which does not possess any refinery capacity of its own, the responsibility for all functions is held by local Managing Directors who report directly to the Group's Executive Board.

There are two management levels in the Plastics segment: managing directors at the international sites report to the divisional management team,

## G.04 PRESENTATION OF GROUP STRUCTURE

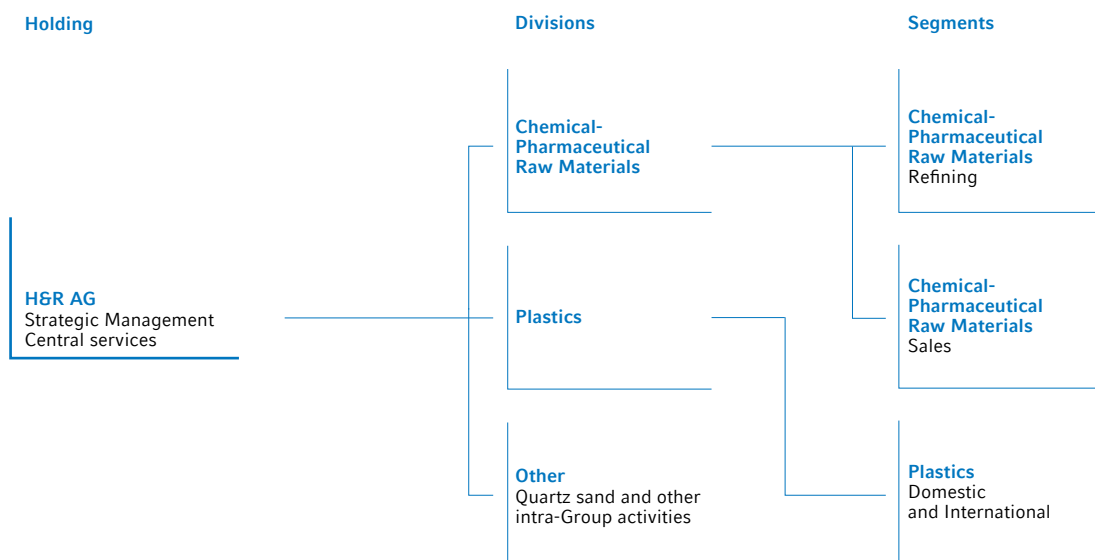

which is also responsible for managing the domestic production plant in Coburg, Germany.

## Locations

At year-end 2014, our Group employed 1,500 people worldwide. The following overview shows our most important sites with more than 20 employees:

## T.12 MAIN SITES IN THE H&amp;R GROUP

Continent	Country	City	Business Division	Employees
Africa	South Africa	Durban	Chemical-Pharmaceutical Raw Materials	33
Asia	China	Wuxi	Plastics	151
		Ningbo/Daixi	Chemical-Pharmaceutical Raw Materials	103
		Fushun	Chemical-Pharmaceutical Raw Materials	42
	Thailand	Bangkok/Si Racha	Chemical-Pharmaceutical Raw Materials	35
Australia	Australia	Laverton	Chemical-Pharmaceutical Raw Materials	22
Europe	Germany	Hamburg	Chemical-Pharmaceutical Raw Materials	259
		Salzbergen	Chemical-Pharmaceutical Raw Materials	262
		Coburg	Plastics	347
		UK	Tipton	Chemical-Pharmaceutical Raw Materials
	Czech Republic	Dačice	Plastics	92

**Group fundamentals**

Group business model and structure

**Main products, services and business processes**

So-called long residue (ATRES) and vacuum gas oil (VGO) are the primary raw materials used at our specialty refineries in Germany. More than 800 other crude-oil-based specialty products are generated in joint production processes from these derivatives obtained from distilling crude oil in fuel refineries. In addition to base oil as a raw material for lubricant production, our products can essentially be broken down into the following groups: plasticizers for the rubber industry, technical and medical white oils, and paraffin/specialty wax products. In our propane deasphalting facilities, we carry out efficient further refinement of by-products; this creates more high-grade crude-oil-based specialty products and a new by-product, bitumen, which is used in road building.

 For further information see the glossary on page 160 f.

While in Hamburg we exclusively manufacture our own specialty products, the Salzbergen production site acts as a service provider: for one of our main customers, we manufacture products to its specifications on a contract basis. At a special filling facility, we also mix lubricants based on different end customers' formulations.

 We also refine crude-oil-based feedstock at the Chemical-Pharmaceutical Raw Materials/Distribution segment's blending and conversion plants. Production here focuses on environmentally friendly, label-free plasticizers and wax emulsions. Partnerships with local producers allow us to lower our investment costs, limit risks and accelerate our growth.

In the Plastics Division, we produce high-precision, injection-molded plastic components as well as the molds required to manufacture them. This division is particularly skillful at producing complex plastic parts that require the use of different types of materials.

**Key sales markets and competitive position**

By consistently focusing on customer needs, we have established a solid market presence in the crude-oil-based specialty products business. A comparative study last published by the renowned U.S. research organization Solomon Associates in 2013 involving around 50% of the worldwide

refinery capacity in the lubricants segment evaluates H&R as being in a good competitive situation: as core elements of our ChemPharm Refining segment, our refineries rank within the first or second quartile of the refineries compared, especially in terms of their efficiency and productivity. The continued validity of this assessment is likewise supported by the fact that H&R's refineries are well established in a market environment which for years has experienced a continual shortage of generating capacity in Group 1 refineries. Thanks to their high percentage of specialty products, the refinery sites can also hold their own against bigger units owned by major oil companies.

Our environmentally friendly, label-free plasticizers are used in rubber blends for almost all well-known car tire manufacturers as well as in additional rubber and caoutchouc products. Our main competitors in this product area are the major oil companies.

Our paraffins are used for a wide variety of applications: in the food industry, for example, cheese rinds are coated with paraffin to prevent the cheese from drying out. The packaging industry has various uses for paraffin, including coating the inside of Tetra Pak containers. In the construction industry, wax emulsions are used to make construction materials water repellent. In this product segment, we and other competing companies jostle for second place behind the market leader.

Thanks to our ability to reliably satisfy high quality standards, we have also established a good reputation in the market for white oils. For instance, our technical white oils are used to clean printing presses or as plasticizers for plastic components. Our medical white oils are found, among other applications, in cosmetic products such as creams and ointments. The large oil companies are other significant producers in this field, too.

We sell the vast majority of our base oils to lubricant manufacturers as a raw material. Using additives, we further process a small quantity of these base oils into ready-made lubricants that are primarily used in agriculture.

The customers of our Plastics Division can be divided into three groups: the automotive industry continues to be the largest by far. Other customer groups are the medical technology industry and other industries. In the latter group, we primarily include products for customers in the electrical, the measuring and control technology and the mechanical engineering segments. The market for plastic components is highly fragmented and comprises several hundred competitors in Germany alone.

#### Legal and economic factors



The production process at our plants in Salzbergen and Hamburg generates residues that are used as components of a bunker fuel containing sulfur. Effective 1 January 2015, the International Maritime Organization (IMO) reduced the maximum permissible sulfur content for bunker fuel in the North and Baltic Seas from 1.0% to 0.1%. New guidelines are also expected to apply to global shipping from 2020. The maximum concentration should fall to 0.5%. Implementing this reduction in the permitted level of sulfur in shipping fuel will most likely restrict the marketing opportunities for our high-sulfur-content residue in the future. By using our propane deasphalting plants, we can convert the residue into environmentally friendly, crude-oil-based specialty products and asphalt for use in the road-building industry. Further products for alternative applications will have to be established over the next few years.

REACH (The European regulation on the Registration, Evaluation, Authorization and Restriction of Chemicals) entered into force in the EU in 2007. The main aim of REACH is to ensure a high level of protection of human health and the environment when dealing with chemical substances. In order to accomplish this goal, REACH places a special level of responsibility on the manufacturer or importer of a substance by requiring it to assess the risks of substances it has brought to market and their uses over the entire life cycle and to register as a manufacturer or importer with the European Chemicals Agency (ECHA). H&R AG has submitted the required documents for all the substances manufactured at its refineries. The assessment (evaluation) phase by ECHA and

domestic agencies is currently underway. Certain substances of very high concern require approval. H&R AG currently uses solvents for which an application must be filed by May 2016. A project team is working to ensure that the relevant documents will be compiled in a timely manner and will be ready to submit before the deadline.

At our specialty refineries in Germany, we primarily use long residue as the feedstock for our products. The price of this derivative, which is produced when crude oil is distilled at fuel refineries, generally correlates with the current price of crude oil. Product margins are usually reduced temporarily as a result of the interaction between raw materials prices and base oil prices. As rising raw materials prices can generally – if at all – only be passed on in higher product prices with a certain time lag, the price of base oil can have a disproportionate effect on margins.

Because of the fact that the production process in the ChemPharm Refining segment takes several weeks, the sharp decline in crude-oil prices may lead to a relative increase in material costs (i.e., an increase in the percentage of the product price accounted for by material costs), to lower margins and, in some cases, even to significant losses (so-called “windfall losses”). The reason for this is that, on the date of their acquisition, the market prices for petroleum-based inputs are considerably higher than the market prices on the date when the primary products manufactured from such inputs are sold.

The market mechanisms of supply and demand also have a general impact on our margins.



For further information see the glossary on page 160 f.



For further information see the glossary on page 160 f.

## Company control

### Internal management system

A value-based management system is used to guide and manage the Group. At the heart of this system is a comprehensive ratio reporting method that supports management in the monitoring of profitability, liquidity, the capital structure and operating performance. In addition to this, we monitor both company-specific and macroeconomic early indicators. At the production level, this includes data relating to plant availability, reject rates and quality fluctuations. In sales and distribution, we examine sales volume statistics, general market data and leading macroeconomic indicators.

The system also consists of monthly reports from the divisions, the management of risks and opportunities and our functional management structure, whereby responsibility is assigned for more than one site in important areas such as raw materials purchasing, project management and sales/distribution.

Over the past two years, we have shifted the focus of our control instruments to more short-term performance parameters in response to changes in the overall economic environment. We measure and control profitability, in particular, through profit contributions. Manufacturing planning is based on optimizing contribution margins; the business segments are controlled by means of EBITDA and EBT ratios.



For further information see the glossary on page 160 f.

The long-term WACC (Weighted Average Cost of Capital) ratio, which consists of the weighted capital costs of our equity and borrowed capital, once again was not taken into account as a control parameter during the course of the year; however, it was used in the medium and long-term planning. This also applies to the ROCE profitability ratio (Return On Capital Employed), which compares earnings before interest and taxes to the average committed capital necessary for operations.

LIQUIDITY. By constantly focusing on our free cash flow, we ensure that the H&R Group will continue to be financially solid in the future. Our free cash flow is essentially determined by the operating result (EBITDA), the change in net working capital (total of inventories and trade accounts receivable less trade accounts payable) and capital expenditure/investments. In general, our cash flow, which is a consequence of the business model, shows a high level of volatility due to changes in net working capital, in particular when deliveries of raw materials for our refineries occur around the same time as the balance-sheet reporting dates.

T. 13 FREE CASH FLOW

IN € MILLION	2014	2013	2012	2011	2010
Cash flow from operating activities	-0.4	88.9	84.7	-11.8	52.1
Cash flow from investing activities	-10.1	-16.2	-33.7	-42.3	-32.8
Free cash flow	-10.5	72.8	50.9	-54.2	19.3

In 2014, the change in cash flow from operating activities primarily reflected the significant changes in net working capital. A comparison of 2014 with 2013 highlights the higher value in 2013: the 2013 net working capital figure is mainly attributable to the conversion of the Salzbergen refinery to contract production as of 1 July 2013, which reduced net debt by €72.0 million. We also achieved positive effects through supplier financing (including guarantees and letters of credit) and by optimizing inventory management.

In 2014, our investment activities were limited to smaller and medium-sized replacement and modernization projects, as well as expansion work at the site in Pinthong, Thailand. Overall, they totaled €23.9 million, i.e., higher than in the previous year. As a result, after posting positive free cash flow in both 2012 and 2013, we generated negative free cash flow of €-10.5 million in 2014.

**CAPITAL STRUCTURE.** Our goal is to have a balanced capital structure that optimizes the cost of capital for our equity and debt. Under the terms of our [loan agreements](#) and our borrower's note loans, we are obliged to uphold two financial covenants relating to our equity funding and the ratio of our net debt to operating earnings (EBITDA).

Another control parameter relating to our capital structure is net gearing, which compares our net debt to equity. The increase in net debt to €107.3 million (previous year: €73.1 million) due to the contribution of the Chinese businesses and the improved equity ratio caused this ratio to change from 42.2% to 45.8%.

T. 14 CAPITAL STRUCTURE

	2014	2013	2012	2011	2010
Net debt/EBITDA	3.41	2.24	2.96	2.06	1.07
Equity ratio in %	35.2	31.8	34.2	38.0	42.5
Net gearing in %	45.8	42.2	68.6	77.5	48.8

**OPERATING PERFORMANCE.** We essentially measure our operating business based on sales and absolute earnings indicators such as [EBITDA](#), EBIT and EBT, as well as by sales volumes of our chemical-pharmaceutical specialty products. The crude-oil price trend always has a direct impact on the cost of materials, which affects H&R AG's sales revenues for reasons related to the business model. On its own, our revenue is therefore only of limited use as a performance indicator.

We calculate the sales and EBITDA figures both for the individual segments and for the Group as a whole. Together with net indebtedness, they constitute the main significant parameters for controlling and managing our company.

T. 15 EARNINGS AND VOLUME GROWTH

IN € MILLION	2014	2013	2012	2011	2010
Sales volume main products in KT <sup>1) 2)</sup>	697	734	839	872	932
EBITDA	31.5	32.6	49.4	89.1	103.4
EBIT	5.8	-4.1	25.5	68.1	82.0
EBT	-7.8	-16.8	1.6	54.5	73.6

<sup>1)</sup> Chemical and Pharmaceutical Raw Materials Division.

<sup>2)</sup> The figures only include the fourth quarter of 2014 for the Chinese operations.

## Research and development

### Focus of our R&D activities

Our crude-oil-based specialty products and plastic parts are directly incorporated into our customers' products; we cooperate closely with them to optimize the value of the components we supply for their end products. Another focus of our R&D work is on boosting the efficiency of our production processes, thereby increasing the value we add. Research activities are managed at the divisional level.

Our Chemical-Pharmaceutical Division operates R&D laboratories at its domestic refineries. In China, the focus of our labs is on paraffin. Valuable synergies are created both from communication between these areas and from exchanging ideas with other production areas. We apply a similar concept in the Plastics Division by combining our R&D work at the headquarters in Coburg.

As in prior years, in 2014 we once again collaborated closely with universities and research institutes. To the extent possible and expedient, we try to protect our own research results from external use through patents. We did not receive any subsidies or other funding for research activities.

**CHEMICAL-PHARMACEUTICAL RAW MATERIALS.** Our products, which overall total around 800, are used as inputs in more than 100 different industries. Equally large is the potential for the development of new or improved products. Our sales/distribution staff and partners are an important source of ideas for product innovations. As a result of their long-term customer relationships, they have an excellent feel for how clients' needs change over time. In particular, our research activities focus on the paraffin, plasticizer and white-oil product groups. In addition to existing patents, over the reporting period our research activities have led to further patent applications relating to alternative production methods for some of our specialty products.

We are also researching processes that could increase the yield of crude-oil-based specialty products from our raw materials and thereby further improve the level of value added at our refineries. The promising results of this research work have



For further information see the glossary on page 160 f.



For further information see the glossary on page 160 f.

**Group fundamentals**  
Research and development

influenced our investment planning: while in the past we focused mainly on expanding our production capacity, in recent years we have increased our investments in plants that can further refine our products.

The division's collaboration with the universities of Hamburg, Hanover, Magdeburg, Munich, Rostock (all Germany), Bangkok (Thailand) and Enschede (the Netherlands) forms an important part of its research activities. These partnerships give us access to the universities' research infrastructure and enable us to establish contact with high-potential R&D candidates at an early stage.

**PLASTICS.** The use of increasingly sophisticated technologies in vehicles to reduce fuel consumption and CO<sub>2</sub> emissions is leading to a growing demand for lightweight and simultaneously complex plastic parts. We often develop such parts – which consist of several different materials – in conjunction with our clients, who are direct suppliers to

automobile manufacturers. We further expanded our research and development work in the field of medical technology – an increasingly important market segment for the Plastics Division.

**R&D expenses, staff and key figures**

The importance of our research activities has for years been reflected in our consistently high spending and the increase in the number of people we employ in this area. All employees in the Research & Development department have outstanding qualifications, either in the form of technical training in a chemicals-related profession or in some cases a master's qualification. Other staff, such as engineering graduates, are as highly qualified as our employees who hold doctorates in chemistry. At nearly €1.9 million, R&D spending was roughly the same as the prior-year figure. Our R&D ratio, defined as R&D expense divided by sales revenues, increased slightly from 0.16% to 0.17% due to the decrease in revenues.

**T. 16 RESEARCH AND DEVELOPMENT COSTS**

IN € THOUSAND	2014	2013	2012	2011	2010
Research and Development costs	1,909	1,906	2,072	2,117	1,783
of which Chemical-Pharmaceutical Raw Materials Division	1,563	1,585	1,720	1,817	1,424
of which Plastics Division	346	321	352	300	359
as % of annual revenue	0.17	0.16	0.17	0.18	0.17



# Financial report

## Macroeconomic conditions

In 2014, around 66.0% of H&R AG's sales were generated in Germany. Germany's economic expansion, which initially led economic researchers to make very optimistic assumptions about expected growth for the full year, did not continue in the second half of 2014. The escalation of the conflict in Ukraine dampened export expectations and domestic companies postponed investments. Nevertheless, German economic analysts are

sticking to their forecast of a very strong recovery over the medium term, driven primarily by the extremely low interest rates. Following near stagnation in the third quarter of this year, experts expected macroeconomic output to increase in the final quarter. Overall, the experts at the Institute for the World Economy in Kiel (IfW) ultimately reckoned on an increase in the gross domestic product of 1.4% in 2014.

### G.05 EXCHANGE RATES US\$ PER € IN 2014

(CLOSING RATE US\$ PER €)



The euro, which is the functional currency used to calculate the earnings trend at H&R AG, came under much more pressure in 2014 than in the prior year. Above all, the improved American economic figures strengthened the dollar as the international reserve currency, causing it to appreciate markedly against the euro.

The global economy also benefited from economic performance in the United States, while growth continued to be subdued in the emerging markets in 2014. According to the IfW, global production probably increased by around 3.2% in 2014.

### G.06 OIL PRICES 2010-2014

(AVERAGE MONTHLY PRICES)

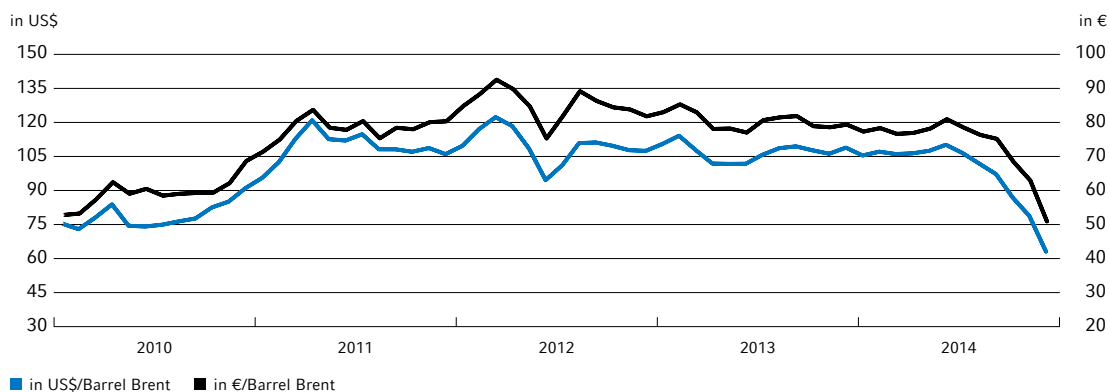

**Financial report**

Overview of business performance

**i**  
For further  
information  
see the glossary  
on page 160 f.

Crude-oil prices (all data refer to the average price of a barrel of North Sea Brent) increased moderately through mid-year, but then jumped excessively: from January to the end of December, the price of crude oil ranged from a low of US\$57.51 to the high in June of US\$115.01.

**Industry-specific climate**

Although the chemical industry association (VCI) was still in a good mood at mid-year, by the fall the news was dominated by much more negative statements. In particular, high energy prices in Germany were denounced as “poison” for the competitiveness of the chemical industry.

By contrast, at year-end, the association’s forecasts were somewhat more positive: by the late autumn, the chemical industry’s output and sales revenues had surpassed those of the previous year, with prices remaining stable. Once again, the positive performance was explained by foreign business, while business with domestic customers decreased again. The VCI therefore worded its expectations carefully and corrected the projected increase in production slightly, to 1.5%. The correction was also reflected in revenue growth, which was forecast at 1% for the industry as a whole.

**Overview of business performance**

In 2014, H&R AG sold a total of 697,000 tons of primary products in the Chemical-Pharmaceutical Raw Materials Division (2013: 734,000 tons). The conversion to contract manufacturing resulted in significant economies of scale, which were reflected in full-year figures for the first time in 2014. At the same time, the use of high-quality feedstock resulted in changes in the way the Hamburg refinery is operated, leading to slightly lower production but positively affecting the ratio of primary products to by-products for the long term. The decrease in the price of raw materials affected the cost of materials, which because of the business model in turn affects the amount of sales revenues. At the same time, the continued weakness of crude oil also had negative effects. In

particular, this impacted the raw materials stored at the Hamburg refinery (OWS). Large stocks of raw materials purchased at prices that were significantly higher than current market prices still had not been processed because of the length of the production run, which takes several weeks. At the same time, the lower price of crude oil affected primary products and by-products that had already been produced: the manufacturing and replacement costs for these products are largely commodity-driven and consequently had to be stated at amounts that were lower than on the production date, also because of the joint process. These effects, which we recognize as “windfall losses”, totaled around €-13.4 million for the fourth quarter alone (entire year of 2014: €-16.1 million), despite compensating positive effects, such as acceptable margins. The company’s consolidated operating income (EBITDA) totaled €31.5 million (2013: €32.6 million).

**Events with a major impact on the course of business**

The Group’s total sales revenues of €1.06 billion were lower than the prior-year level (2013: €1.21 billion).

During financial year 2014, the Salzbergen refinery for the first time processed third-party raw materials as a contract manufacturer for the entire year. The conversion during the summer of 2013 meant that only six months of 2013 fell under this model. To that extent, the two sales revenue figures are not directly comparable; in particular, the lower level of revenues in 2014 does not indicate any basic change in demand or production. During the past financial year, commodity prices and the way the Hamburg refinery is run were the decisive factors here.

Contract production primarily resulted in positive effects on the earnings side, because it eliminated the risk of financing and the risk of “windfall losses” for the raw material inventories at the Salzbergen site. Combined with the financing terms, which were renegotiated in early 2014, this gave H&R AG significantly more room for maneuver to take advantage of opportunities in the commod-

ities market. Actively controlling the quality of various raw materials and targeting yields have significantly affected our product mix in favor of primary products. As a result, in the spring we were able to quickly react to sudden price pressure on our by-products, considerably reducing the pressure on earnings. In order to further strengthen earnings, Management in the past has initiated wide-reaching cost-reduction projects in all Group Divisions. In the process, all the major cost areas were analyzed and sustainable steps were taken to reduce costs. However, in 2014 fixed costs reached a level of efficiency beyond which no further reductions of note will be possible. At the same time, our plants operated without disruptions and enjoyed high capacity utilization. With the exception of the scheduled shutdowns for routine tests, we were able to keep operating interruptions to a minimum. Finally, the trend in crude-oil prices and prices for the volume product – base oil – were also important to our earnings performance. Above all, from early summer on, we benefited from good prices for our base oil. At the same time, we benefited from lower crude-oil prices on the purchasing side.

However, toward the end of the year, this trend also began to have increasingly negative effects: after OPEC decided not to restrict its members' production quotas (and thereby not to transmit any signals to stabilize and/or cause the price of crude oil to recover), Brent dropped under €60.00 per barrel. As a result, the value of our existing inventories dropped considerably due to the purchase of cheaper raw materials. Because the inventories we had previously purchased at high

prices had not yet been used in the joint process, we had to recognize “windfall losses”. They totaled € -16.1 million, including € -13.4 million in the fourth quarter of 2014 alone. This one-time effect had a noticeable impact on our earnings (EBITDA), which totaled €31.5 million despite good operating performance and acceptable margins. This earnings figure also includes only one quarter of EBITDA contributions from China, which added around €2.0 million.

#### Comparison of the actual course of business with the forecast made in the previous year

The figures from the two previous years had a decisive impact on the expectations with which H&R AG started financial 2014. The business and profit projections for 2014 were more conservative than in 2013: initially, we were still expecting operating income (EBITDA) of around €40.0 million – approximately the same as for the two previous years. During the summer, we first made slight adjustments to these expectations, rating the earnings target as “ambitious”. At the same time, we expected a “noticeable improvement compared to the previous year’s results”. With the publication of the preliminary figures for the first nine months, we confirmed this expectation, but reduced the sales revenue target to around €1.1 billion, which was below 2013 sales revenues. Ultimately, we posted revenues of €1.06 billion.

Because of the aforementioned “windfall losses”, the €31.5 million of EBITDA reported on the consolidated income statement for financial year 2014 was below the level of operating income forecast in 2013.

#### T. 17 FORECAST FOR FINANCIAL YEAR 2014

Forecast date	31/3/2014	14/8/2014	14/11/2014*	17/12/2014	Actual value
Sales in the Chemical-Pharmaceutical Raw Materials Division	≈ €1.100 million to €1.200 million	not defined	€1,100 million	not defined	€1,002.1 million
Sales in the Plastics Division	≈ €55 million to €60 million	not defined	not defined	not defined	€56.5 million
EBITDA at Group level	≈ €40 million	> €32.6 million	> €32.6 million	≈ €29.0 million to €33.0 million	€31.5 million

\* Total sales proceeds were updated.

**Financial report**

Economic position of the H&amp;R Group

The Chemical-Pharmaceutical Raw Materials Division posted sales of €1,002.1 million, a figure that was both below the prior-year level (2013: €1,151.7 million) and rather significantly below the lower end of the range forecast at the beginning of the year.

The decrease in the price of raw materials had a major impact on the cost of materials, which in turn because of the business model affected the amount of sales revenues.

By contrast, the Plastics Division's sales revenues were more in line with the forecast. The segment's €56.5 million of sales came in at the lower end of the range announced in early 2014 but, as expected, still fell below the prior-year value (2013: €62.7 million).

H&R AG's mid-year correction of our operating income target was primarily attributable to the weak figures for the first two quarters of 2014, which mainly suffered from stronger pressure on prices for our by-products. Running counter to this trend, our results benefited from positive momentum over the next few months, at least initially. The lower price of raw materials, a different raw-materials mix and a marked recovery in ICIS pricing for base oils led to better operating performance in the third quarter and at the beginning of the fourth quarter, steering our results in the direction of the EBITDA forecast published during the summer. However, the aforementioned "windfall losses" prevented us from posting better EBITDA than the amount actually achieved of €31.5 million.

Overall, H&R AG certainly considers the business trend in 2014 more favorable than in 2013, with more satisfactory results. Above all, the Executive Board is proud of the way the company has tackled major organizational and structural tasks in the face of the still challenging market situation while holding its own, unlike many other lubricant manufacturers.

**Economic position of the H&R Group****Earnings position**

In financial year 2014, we posted total sales revenues of €1,058.6 million – below the prior-year level of €1,214.4 million. Sales revenues from the Chemical-Pharmaceutical businesses (which accounted for 94.7% of sales revenues in 2014) were lower mainly because of the lower cost of raw materials. In the Plastics business (which contributed 5.3% of sales revenues in 2014), by contrast, the decline in business also reflected lower demand.

Although overall revenues were lower, H&R AG's operating income reached almost the previous year's level. In addition to lower procurement prices, this was primarily due to the more favorable pricing for base oils beginning in the second quarter. The use of higher-value feedstocks benefited our product split in favor of a higher share of primary products.

The regional focus of our business activities remains on Germany, where 65.7% of sales revenues were generated. This percentage includes transactions with our sales partner – the Hansen & Rosenthal Group, which in turn generates a large proportion of its sales revenues outside of Germany. The actual percentage of products purchased by foreign end customers is therefore higher than our statistics suggest. Of the remaining 34.3% of sales revenues, other European countries account for 12.7% and the rest of the world contributes 21.6%.

H&R AG faced some challenges at the beginning of the financial year, because figures for the first quarter of 2014 were below those of the fourth quarter of financial year 2013. At the same time, it became clear early on that the conversion of the business model for the Salzbergen refinery to contract manufacturing delivers more stable earnings contributions, even when sales revenues are lower.

We also renegotiated our financing terms at the beginning of the year. As a result, the rigid covenants that still applied in 2013 were relaxed during the year, giving us more flexibility to purchase and use raw materials.

We took advantage of this new leeway and positively changed our product mix through the use of more expensive, higher-quality raw materials. The proportion of by-products, which came under price pressure at the beginning of the year, was reduced significantly during 2014.

Positive effects on the market side, such as the aforementioned trend in crude-oil and base-oil prices, resulted in additional momentum, but were more than offset by the one-time effect already described. As a result, consolidated operating income (EBITDA) fell by 3.4% to €31.5 million (previous year: €32.6 million). The EBITDA margin rose by 0.3 percentage points to 3.0% (2013: 2.7%).

Overall, the other earnings indicators improved. For example, consolidated earnings before interest and taxes (EBIT) improved considerably, from €-4.1 million in 2013 to €5.8 million.

Earnings before taxes (EBT) also increased significantly, from €-16.8 million in 2013 to €-7.8 million in 2014. Consolidated earnings/loss after minority interests stood at €-15.4 million (previous year: €-14.0 million). After a net loss per share of €-0.44 in the prior-year period, the company reported a net loss per share of € -0.49 for 2014.



For further information see the glossary on page 160 f.

#### T. 18 CHANGE IN SALES REVENUES AND EARNINGS

IN € MILLION	2014	2013	2012	2011	2010
Sales revenues	1,058.6	1,214.4	1,228.9	1,209.5	1,056.8
Operating result (EBITDA)	31.5	32.6	49.4	89.1	103.4
EBIT	5.8	-4.1	25.5	68.1	82.0
Earnings before taxes	-7.8	-16.8	1.6	54.5	73.6
Consolidated earnings before minority interests	-15.6	-14.0	0.4	38.5	52.0
Group profit/loss after minority interests	-15.4	-14.0	0.5	38.5	52.0
Earnings per share (€)	-0.49	-0.44	0.02	1.29	1.74

#### Orders trend

For 2014 as a whole, new orders for products in our Chemical-Pharmaceutical business remained at a stable level.

In a year of restructuring, figures for much of the Plastics Division remained below those of the previous year, but again ended the year at around €36.2 million, about the same level as in 2013 (31 December 2013: €36.8 million). However, considered individually, the order book in the tool-making segment is a positive indicator for the future, as it points to an increase in series-production business.

#### Trends in the main items on the income statement

Inventories of finished and unfinished products rose by €0.4 million during the reporting period. In the previous year, this income-statement item stood at €-56.5 million due to the disposal of the

Salzbergen inventories in connection with the conversion to contract production.

The change was primarily attributable to the conversion of the Salzbergen refinery site to contract production. Unlike in earlier years, since mid-2013 the raw-material inventories as well as the finished and semi-finished products manufactured there have been owned by the customer.

In financial year 2014, our cost of materials declined by 10.2% to €881.4 million (previous year: €981.3 million), as a direct result of the reduction in the cost of raw materials. The material expenditure rate decreased from 84.7% in the prior-year period to 83.2%, mainly due to the decrease in the price of raw materials and to better operating margins.

## Financial report

Economic position of the H&amp;R Group

## T.19 DEVELOPMENT OF MAIN ITEMS IN THE INCOME STATEMENT

IN € MILLION	2014	2013	2012	2011	2010
Revenue	1,058.6	1,214.4	1,228.9	1,209.5	1,056.8
Changes in inventories	0.4	-56.5	-6.4	29.0	20.3
Other operating income	18.7	22.3	19.7	21.0	21.3
Cost of materials	-881.4	-981.3	-1,017.4	-987.3	-812.8
Personnel expenses	-72.7	-71.4	-72.9	-76.2	-74.5
Depreciation and amortization	-25.6	-36.7	-23.9	-21.0	-21.4
Other operating expenses	-92.4	-95.2	-102.9	-107.2	-108.1
<b>Operating profit/(loss)</b>	<b>5.7</b>	<b>-4.5</b>	<b>25.2</b>	<b>67.8</b>	<b>81.7</b>
Financial result	-13.5	-12.4	-23.6	-13.4	-8.1
<b>Earnings before taxes</b>	<b>-7.8</b>	<b>-16.8</b>	<b>1.6</b>	<b>54.5</b>	<b>73.6</b>
<b>Consolidated earnings before minority interests</b>	<b>-15.6</b>	<b>-14.0</b>	<b>0.4</b>	<b>38.5</b>	<b>52.0</b>
<b>Group profit/(loss) after minority interests</b>	<b>-15.4</b>	<b>-14.0</b>	<b>0.5</b>	<b>38.5</b>	<b>52.0</b>

The contribution of the Hansen & Rosenthal Group's Chinese businesses to H&R AG increased the number of employees, thereby raising personnel expenses by 1.8% to €72.7 million (previous year: €71.4 million).

Depreciation and amortization decreased from €36.7 million in 2013 (when these charges still reflected unscheduled write-downs of goodwill and of property, plant and equipment at the Hamburg refinery based on the impairment test at the end of the third quarter) to €25.6 million. After adjusting for the prior-year effect, there was a relatively slight increase in depreciation and amortization related to the contribution of the Chinese businesses.

Interest expense declined again in 2014. This was attributable both to the company's lower debt,

lower waiver fees, such as the cost of updating individual covenants as a result of the contribution of the Chinese businesses, and lower expenditures for interest-rate swaps. The company reached an agreement with one of the creditors of the five-year tranche of the borrower's note loan to repay that creditor's €3.0 million share early without any additional cost, i.e., in the form of an early repayment penalty.

The financial result of €-13.5 was slightly worse than in the previous year (2013: €-12.4 million). In 2014, we had a tax expense of €7.8 million, compared to tax earnings of €2.8 million in 2013. The negative effective tax rate of 99.3% was primarily attributable to the non-recognition of deferred tax assets from loss carryforwards and provisions for deferred tax assets.

## G.07 REVENUE BY SEGMENT IN 2014

IN % (PREVIOUS YEAR'S FIGURES)

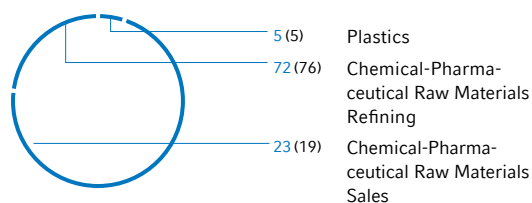

## G.08 REVENUE BY REGION IN THE CHEMPHARM REFINING SEGMENT IN 2014

IN % (PREVIOUS YEAR'S FIGURES)

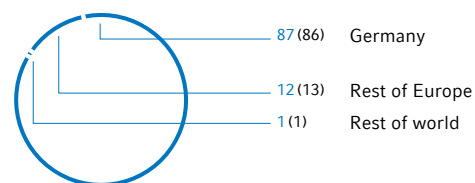

**G. 09 REVENUE BY REGION IN THE  
CHEMPHARM REFINING SEGMENT IN 2014**

IN % (PREVIOUS YEAR'S FIGURES)

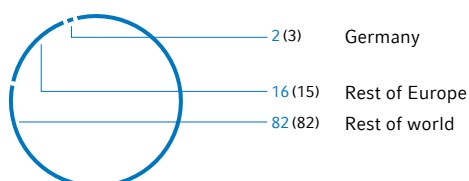
**G. 10 REVENUE BY REGION IN THE  
PLASTICS SEGMENT IN 2014**

IN % (PREVIOUS YEAR'S FIGURES)

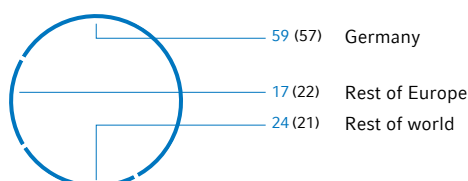
**Earnings trends by segment**

**CHEMPHARM REFINING.** Sales volumes of primary products at our Group's largest segment were lower than in the previous year because contract manufacturing was in effect for the full year. However, lower raw-material prices had a decisive impact on segment sales in financial year 2014; because of our substantial material requirements, the lower commodity prices reduced material costs and thus our sales revenues. Overall sales revenues declined by 18.3% to € 768.7 million (previous year: €941.0 million). Despite the aforementioned pricing and market situation and more acceptable base-oil prices, "windfall losses" caused the segment's operating income (EBITDA) to deteriorate by 11.7% to €18.2 million, compared to €20.6 million in the previous year.

**CHEMPHARM SALES.** In the international segment, sales revenues rose by 5.6%, to €244.7 million (previous year: €231.7 million), primarily because

of the takeover of the Chinese businesses. Because of the higher proportion of specialty products with stable margins in the product portfolio, operating income (EBITDA) increased by 13.9% from €16.5 million in 2013 to €18.8 million in 2014. Contributions from the takeover of the Chinese sites were included only for the last quarter of 2014.

**PLASTICS.** In our Plastics Division, sales declined to €56.5 million (2013: €62.7 million). Despite a slight increase in volumes in the second half of the year, the sites in Wuxi, China, and Coburg, Germany failed to meet expectations. After recording an operating profit (EBITDA) of €0.7 million in the previous year, we reported a negative EBITDA of €-1.5 million in the reporting period. A slightly positive uptrend at the end of the year was not sufficient to reverse this development.

**T.20 KEY FIGURES BY SEGMENT (IFRS)**

IN € MILLION	2014	2013	2012	2011	2010
<b>Revenue</b>					
Chemical and Pharmaceutical Raw Materials Refining	768.7	941.0	952.2	943.2	808.1
Chemical and Pharmaceutical Raw Materials Sales	244.7	231.7	254.1	249.6	229.8
Plastics	56.5	62.7	55.6	52.6	42.8
Carry-over	-11.3	-21.0	-33.0	-35.9	-23.9
<b>Operating result (EBITDA)</b>					
Chemical and Pharmaceutical Raw Materials Refining	18.2	20.6	33.1	71.3	86.7
Chemical and Pharmaceutical Raw Materials Sales	18.8	16.5	19.3	19.0	20.7
Plastics	-1.5	0.7	-0.8	2.3	-0.3
Carry-over	-3.9	-5.1	-3.2	-3.5	-3.7



## Financial report

## Net assets and financial position

## Net assets and financial position

### Financial management principles and objectives

Our finances are managed centrally by the holding company H&R AG. The overriding objectives of this function are as follows:

- to provide the company with sufficient liquidity and to use it efficiently
- to finance working capital and capital expenditure
- to hedge against financial risks
- to ensure compliance with financing terms
- to optimize our capital structure

To make efficient use of our liquidity, we transfer surplus cash within Germany to a cash pool which supplies the subsidiaries with the necessary liquidity.

In November 2011, borrower's note loans and a syndicated loan were initiated: the borrower's note loans currently total €116.0 million with maturities until 2016 and 2018 and serve mainly to refinance already existing investments.

Back in 2013, as a result of the conversion of the Salzbergen refinery site and the related reduction in our working-capital requirements, we reduced the syndicated loan, which had a term of five years and a maximum original utilization of €150.0 million. In line with our changed financing requirements, in February 2014, the parties agreed to convert the syndicated loan to a letter of credit and cash credit line, which was simultaneously increased by a further €12.5 million to a total of €72.5 million.

 For further information see the glossary on page 160 f.

### T.21 MAIN FINANCING INSTRUMENTS IN THE H&R GROUP

	Sum in € million	Year issued	Maturity
Syndicated loan	up to 72.5	2011	30/11/2016
Bonded loans	63.0	2011	30/11/2016
Bonded loans	53.0	2011	30/11/2018
Syndicated loan (redeemable loan)	50.0 <sup>1)</sup>	2011	30/12/2020
Redeemable loan	20.0 <sup>1)</sup>	2009	30/6/2019
IN € MILLION	2015 <sup>2)</sup>	2013	2012
Trends in the consolidated net financial debt	≈128.8	107.3	73.1

<sup>1)</sup> Before capital repayments.

<sup>2)</sup> Forecast earnings development.

As part of another syndicated loan, we took out ten-year loans in May of 2009 (€20.0 million) and in January of 2011 (€50.0 million) via the KfW [Kreditanstalt für Wiederaufbau/Reconstruction Credit Corporation]. These loans are part of a funding scheme which offers financing for environmentally friendly investments under (what at that time were) particularly favorable conditions.

In addition to other conditions, the utilization of the loans is subject to two covenants: the ratio of net debt to operating income (EBITDA) and the economic equity ratio.

The interest expense on one €80.0 million tranche of the borrower's note depends on the general trend in money-market rates. In order to increase certainty in planning our future interest payments

and to lock in historically low interest rates for the long term, we entered into interest-rate hedges on this loan amount.

We largely avoided using derivatives to hedge against the risks inherent in raw-material prices, exchange rates and other risks during the reporting period because, in our view, the cost of these instruments exceeded the potential benefit.

### Analysis of the cash flow statement

Based on the consolidated net loss of € -15.6 million, net cash used in operating activities totaled €-0.4 million (previous year: cash flow of €88.9 million). The €82.2 million change in net working capital in 2013 dropped to €2.2 million in 2014. The 2013 figure was caused by the conversion of the Salzbergen facility to contract production and



the resulting sale of inventories to the customer. Moreover, while there was a €1.9 million cash inflow from income taxes received in 2013, there was a cash outflow of €7.1 million during the year under review. Cash flow from investing activities increased to €-10.1 million (previous year: €-16.2 million). Expenses related to the replacement of capital assets at our refineries and expansion of the new Chinese sites and in Pinthong, Thailand were offset by deposits received in connection with the acquisition of subsidiaries (cash on hand in China). Overall, free cash flow (the sum of cash flow from investing and operating activities) declined to €-10.5 million (previous year: €72.8 million). Financing activities resulted in a net use of cash of €-0.3 million (previous year: €-49.2 million). This item was mainly affected by incoming payments from the Chinese minority shareholder in the amount of €5.0 million to repay a loan of the Hong Kong subsidiary that was contributed;

lower repayments of financial liabilities of around €26.3 million (2013: €-49.6 million); and incoming payments of €20.8 million (2013: €0.1 million) from newly contracted financial liabilities relating to the contribution of the Chinese businesses). At the end of the reporting period, cash and cash equivalents amounted to €101.6 million, compared to €109.6 million one year earlier. A review of the first quarter of 2014 alone shows that the company reported operating cash flow of €18.9 million. Because of the decrease in investment activities, free cash flow stood at €10.8 million in the fourth quarter of 2014.

Existing payment obligations in the current year under finance leases total €0.6 million and under operating leases, €4.8 million. The total amount of liabilities to banks maturing in 2015 was €52.0 million as of the reporting date.

#### T.22 FINANCIAL POSITION

IN € MILLION	2014	2013	2012	2011	2010
Cash flow from operating activities	-0.4	88.9	84.7	-11.8	52.1
Cash flow from investing activities	-10.1	-16.2	-33.7	-42.3	-32.8
Free cash flow	-10.5	72.8	50.9	-54.2	19.3
Cash flow from financing activities	-0.3	-49.2	-15.3	91.3	-26.9
Financial resources as of 31/12	101.6	109.6	89.6	53.1	16.2

#### Capital expenditure

During the reporting period, our €23.9 million of capital expenditure was considerably higher than in the prior-year period (2013: €13.1 million).

These investments went almost entirely for property, plant and equipment.

#### T.23 CAPITAL EXPENDITURE SEGMENT

IN € MILLION	2014	2013	2012	2011	2010
Chemical and Pharmaceutical Raw Materials Refining	18.1	12.0	30.8	37.9	33.3
Chemical and Pharmaceutical Raw Materials Sales	4.7	0.5	1.8	1.3	3.5
Plastics	0.8	0.6	3.3	1.4	1.6
Reconciliation (other activities)	-0.1	-	0.8	0.5	0.9
Group	23.7	13.1	36.7	41.1	39.3

## Financial report

## Net assets and financial position

We invested a total of €22.8 million (previous year: €12.5 million) in the Chemical-Pharmaceutical Raw Materials Division in the 2014 financial year. In total, this reduced our investments by 61.7%. After a significant overall decline in capital expenditures at the German sites in 2013, a major portion of this total (€18.1 million) has once again been invested in expansions and replacements at the Hamburg und Salzbergen refineries. The division's remaining €4.7 million of capital expenditures were divided among our international sites, with a significant share going to the Pinthong Project in Thailand.

Capital expenditure in the Plastics Division rose slightly from €0.6 million in 2013 to €0.8 million in the reporting year. We invested somewhat less than half of the amount in measures at the Coburg site. The rest was divided between our Czech site and the business in China.

Because of the investment in our refineries, the bulk of our capital expenditure (at 76.3% of total expenses – prior year 91.6%) again took place in Germany.

## G.11 INVESTMENT BY REGION 2014

IN % (PREVIOUS YEAR'S FIGURES)

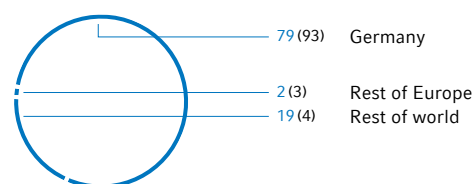

## T.24 NET CAPITAL EXPENDITURE VOLUME

IN € MILLION	2014	2013	2012	2011	2010
Capital expenditure	23.7	13.1	36.7	41.1	39.3
Depreciation	25.6	36.7	23.9	21.0	21.4
Disposal of assets	0.7	0.2	0.4	0.6	0.1
<b>Net capital expenditure volume</b>	<b>-2.7</b>	<b>-23.8</b>	<b>12.4</b>	<b>19.5</b>	<b>17.8</b>

## Balance sheet analysis

The first-time consolidation of the Chinese businesses at the end of the third quarter resulted in a significant change in balance-sheet figures. For example, total assets increased by 18.8% to €706.6 million at 31 December 2014 (31 December 2013: €594.7 million). The significant changes are related to the increase in capital through a contribution-in-kind implemented in September 2014 and the associated contribution of 51% of the Hansen & Rosenthal Group's Chinese businesses to H&R AG.

On the asset side, cash and cash equivalents dropped 7.3% to €101.6 million on 31 December 2014, compared to €109.6 million at the end of 2013. Trade receivables decreased by 3.7% to €105.6 million at the end of the reporting period (31 December 2013: €109.7 million). The de-

crease in this balance-sheet item was attributable to the valuation on the reporting date.

As a result of the contribution of the Chinese businesses and the valuation of inventories in China, inventories increased by a considerable 15.5% to €134.2 million (2013: €116.2 million). For the same reason, other assets increased from €3.7 million to €8.6 million.

Overall, as of 31 December 2014, current assets had increased by 3.7% to €353.9 million, compared to €341.4 million at the end of 2013. As a proportion of total assets, they decreased to 50.1% (31 December 2013: 57.4%).

Non-current assets increased by 39.3% during financial year 2014 to €352.8 million, compared to

## G.12 ASSETS 2014

IN € MILLION (PREVIOUS YEAR'S FIGURES)

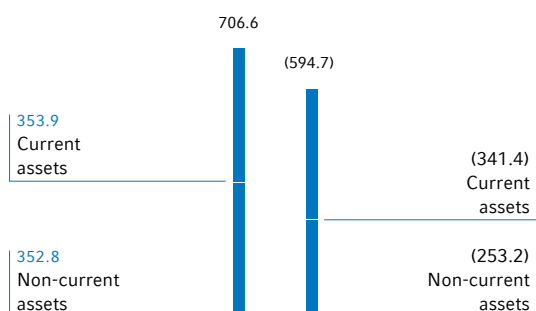

## SHAREHOLDERS' EQUITY AND LIABILITIES 2014

IN € MILLION (PREVIOUS YEAR'S FIGURES)

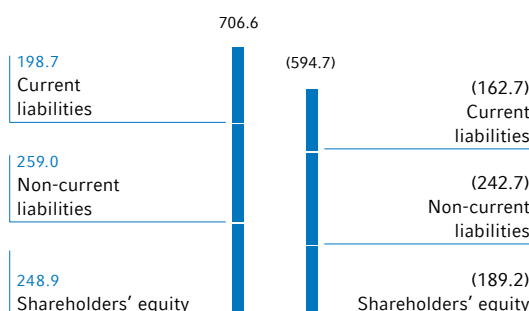

€253.2 million on 31 December 2013. This growth was driven primarily by the 29% increase in property, plant and equipment, from €197.9 million to €255.3 million. Among other things, this figure included the newly added sites in China.

On the shareholders' equity and liabilities side, current liabilities rose by 22.1%, from €162.7 million to €198.7 million. As a proportion of total liabilities and shareholders' equity, they increased to 28.1% (31 December 2013: 27.4%). Liabilities to banks, which increased from €13.3 million to €52.0 million as a result of the contribution of the Chinese businesses, were partially offset by the decrease to €112.4 million (31 December 2013: €121.7 million) of trade accounts payable due to the drop in procurement prices for shipments of our raw materials. While other financial liabilities increased from €4.6 million to now €12.8 million, at the same time other liabilities dropped from €11.9 million to now €9.9 million.

During the same period, non-current liabilities increased by 6.7% to €259.0 million (31 December 2013: €242.7 million), representing a change from 40.8% to 36.7% of total shareholders' equity and liabilities.

Thanks to the contribution of the Chinese businesses, at the end of the reporting period, H&R AG's shareholders' equity totaled €248.9 million, around 31.6% higher than in the previous year (31 December 2013: €189.2 million).

Retained earnings, including consolidated net income, dropped 28.2% to €73.8 million, compared to €102.8 million at the end of 2013. By contrast, positive currency-translation effects led to an increase in shareholders' equity.

In line with the shareholders' equity figure, the equity ratio also improved. It remained at a solid 35.2% as of the reporting date (31 December 2013: 31.8%). Net gearing (the ratio of net debt to shareholders' equity) increased by 3.6%, from 42.2% to 45.8%.

Apart from the aforementioned inclusion of the Chinese businesses, no companies were acquired or sold during the reporting period.

Our off-balance-sheet assets consisted mainly of the leased portion of the refinery site in Hamburg and our fleet of leased vehicles.



For further information see the glossary on page 160 f.

## Non-financial performance indicators

### Sustainability



“Oil is far too good to burn!” – Under this motto, H&R AG is acting not only out of economic necessity – although, ultimately, optimizing the use of our raw materials is also essential to the Company from a financial standpoint.

Indeed, we do not exist within a vacuum. Whenever we operate, we are always aware of our role as partners to our customers as well. We are responsible for our employees and their working conditions. We are part of the communities in which our sites are located and we share the same resources with our neighbors. Therefore, we can only succeed in strengthening our Group and successfully maintaining our position if we act in concert with all other stakeholders in pursuit of the same economic, social and environmental objectives.

In this context, we actively face the manifold challenges involved in our mission. Thus, our customers demand not just the same product quality they have enjoyed for years; instead, nowadays H&R AG must be in a position to deliver these products in an environmentally friendly version, if possible, backed by the appropriate certifications. Guidelines intended to guarantee ethical conduct extend to all partners, in addition to our own company. This also encompasses every aspect of our own value chain.

Demographic change requires us to retain our skilled employees over the long term. We can only succeed in doing so if we offer our employees good jobs and enhanced job security while showing commitment and enthusiasm. And, finally, climate change and the scarcity of resources are becoming increasingly important issues.

The following pages demonstrate what we have already managed to achieve.

### Employees

At year-end 2014, the number of employees at the H&R Group had increased by 148 to 1,553 (31 December 2013: 1,405). The following table shows a breakdown by division:

T.25 EMPLOYEES BY DIVISION

	2014	2013	2012
Employees	1,553	1,405	1,458
of which Chem.-Pharm.	938	801	835
of which Plastics	590	580	578
Other	25	28	45
Personnel expense in € million	72.7	71.4	72.9

Most of our employees work in the domestic refineries in Hamburg and Salzbergen. As of the end of the reporting period, the refineries employed 616 people (31 December 2012: 610).

Our performance-related pay schemes and flat hierarchies also make us an attractive employer for experienced professionals. The increasing complexity of our plants and equipment requires well-trained employees. For example, for the supervision of the processes in the refineries' measurement and control rooms, we deploy only experienced employees who are ready and willing to regularly expand their knowledge base through further training and continuing education.

As we can only compete internationally if we have superbly trained employees on board, we consider our spending on advanced training and professional development to be an investment in the future of our company. When choosing training courses, we follow an individual approach that enhances employees' strengths and helps them to achieve their career goals.

Our employees are characterized by a high degree of loyalty to the H&R Group. This is also demonstrated by the high average seniority and a staff turnover ratio that is consistently low at the sites in Germany.



The age structure of our domestic workforce has remained roughly the same in recent years. During the period under review, the 41-to-50 age group was the largest. The age distribution of our employees is thus typical of industrial companies in Germany.

## Occupational health and safety



A key safety issue at all of our sites is the further training and education of our employees: we hold regular training sessions on topics relating to safety and also require all our employees to visit our Internet-based safety instruction system on a regular basis. Contractors working in our factories are also included in our safety strategy.

Detailed analyses of potential losses, a special report on safety-related ratios, safety inspections and the active involvement of the Executive Board ensure that our safety performance is constantly improving.

Our accident statistics are based on the international CONCAWE standard (CONservation of Clean Air and Water in Europe) which uses the

indicators LWIF (lost workday injury frequency) and LWIS (lost workday injury severity). The LWIF figure shows the frequency of accidents (number of work accidents with at least 1 day lost for every 1 million working hours). The LWIS figure shows the severity of accidents (number of days lost per work accident). Here, both company employees and contractors are taken into account.

The standards we apply are therefore much stricter than those called for by the employers' liability insurance associations in Germany, for instance. During the past year, our safety efforts once again paid off: In 2014, the LWIF figure for our refineries was 1.2 (previous year: 0.0), so our refineries' track record for the past two years is comparable to that of our competitors.

In the field of health care and illness prevention, we make a wide range of programs available to our employees. At the Salzbergen head office, we offer back exercises, nutritional advice, motion training and preventive health care checks.

Similar services are provided for our staff at other H&R Group sites.



For further information see the glossary on page 160 f.

### T.26 OCCUPATIONAL SAFETY AT THE H&R REFINERIES

	2014	CONCAWE-standard	2013	2012	2011
Number of occupational accidents with a least one day lost per million working hours – (Lost Workday Injury Frequency; LWIF)	1.2	1.1	0.0	4.4	6.8
Number of occupational accidents with at least one day lost	2.0	–	0.0	8.0	11.0
Number of days lost due to accidents	56	–	13.0*	195.0	161.0
Number of working days lost per occupational accident (Lost Workday Injury Severity; LWIS)	28.0	33.9	0.0	24.8	14.6
Number of fatal occupational accidents	0.0	4.0	0.0	0.0	0.0

\* Including accidents from the prior year whose days of absence continued over the year change.

**Non-financial performance indicators**

Process safety | Membership of industry associations | Environmental report

## Process safety



As an operator of refineries and production facilities, we are simultaneously entrepreneurs and employers, users of natural resources and neighbors. As such, we are under the obligation to act safely and sustainably. Our refinery processes use a variety of substances that require extremely careful handling. Since the start of 2011, we have measured our performance in this area by means of the PSPI (Process Safety Performance Indicator). To calculate this figure, we track incidents relating to the safety of our processes (PSE – Process Safety Events) per 1 million working hours. We ensure that our results are meaningful by comparing them with the reference figure from the industry association CONCAWE. Since we began recording the PSE, we have always performed better than the CONCAWE benchmark standard.

## Membership of industry associations

Good networking is important not only at the operating level, i.e. with customers and markets, but also within industry associations. As the operator of two specialty refineries, our value creation goes beyond the normal standard of a fuel refinery. We also use different substances in our production process. To protect our interests, we are therefore members of associations for refinery operators and the petroleum industry. Our employees serve as experts on the committees for occupational safety, process safety, environmental protection and refinery technology of the DGMK – Deutsche Wissenschaftliche Gesellschaft für Erdöl, Erdgas und Kohle e.V. [German Society for Petroleum and Coal Science and Technology] and are active members of the CONCAWE Association.

This strong network not only ensures that H&R is kept informed of all major industrial and legal developments on environmental, safety and technological issues, but also that it is in a position to play an active role in shaping these processes.

## Environmental report

Environmental protection and the responsible use of natural resources are key goals of our company policy. On the one hand, we are constantly striving to reduce energy consumption and the amount of environmental pollutants caused by the production process. On the other hand, we also develop environmentally friendly products which either offer an alternative to products containing environmental pollutants or which, by virtue of their use, contribute to protecting the environment.

**ENVIRONMENTALLY SOUND PRODUCTS.** Our label-free plasticizers for the tire industry reduce environmental impact in two ways. Firstly, they improve the environmental compatibility of the tire compounds and tire particles. Furthermore, they lower the rolling resistance of the tires and thereby make an important contribution to reducing fuel consumption.

Our label-free plasticizers are also found in many kinds of lagging and insulation materials used to reduce heat loss from buildings. One of the uses of the white oils produced in our refineries is as components of pesticides to improve the yield of renewable raw materials.

Our paraffins can be used to weatherproof domestic timber varieties. Their use renders intensive deforestation of slow-growing tropical timber stocks unnecessary. The innovative products from our Plastics Division are increasingly being substituted for parts used in the automotive industry that were previously made of metal. The resulting weight reduction helps to reduce vehicle fuel consumption even further. At the same time, the amount of energy used in their production is much lower than for comparable metal components.

**ENERGY EFFICIENCY AND CLIMATE PROTECTION.** In Germany, high energy costs affect particularly energy-intensive production operations. Although H&R AG is entitled to claim the exemptions for energy-intensive production sites for the refineries, it pursues a rigorous, systematic policy of lowering this cost factor at its sites. By the end of 2014, the cumulative savings compared with the 2011 internal benchmark was around 2.1%. This is an advantage that clearly also has a financial



impact. Overall, thanks to greater energy efficiency, in 2014 the two refineries achieved savings of more than €2.3 million, part of which was offset by increasing energy prices.

In order to not only stay competitive but also contribute to protecting the environment at the same time, reducing CO<sub>2</sub> emissions is an important element of our environmental strategy. Given the depth of their value chain (degree of vertical integration), H&R's refineries face particular challenges. In contrast to other refinery operators whose processes end with the production of fuel or base oils, this is the point where our refineries' real role begins, producing higher-grade specialty products. On the one hand, the additional processing stages require further energy inputs, which increases CO<sub>2</sub> emissions. On the other, more high-grade and long-lasting products are produced, which contributes to the conservation of resources.

#### T.27 EMISSIONS BY H&R REFINERIES

PER TON OF FEEDSTOCK	2014	2013	2012
CO <sub>2</sub> for all energy sources (kg/t use)	381.5	397.7	397.6
Waste water (l/t use)	604.7	679.5	717.9
Waste (kg/t use)	2.08	1.59	2.14

CO<sub>2</sub> EMISSIONS. Our CO<sub>2</sub> footprint, together with our direct emissions, also creates indirect effects, e.g. from purchasing additional energy. We account for the depth of our value chain by calculating the sum of all individual plant throughputs in the course of production. For financial year 2014, our emissions per ton of feedstock came to 404.8kg. The past financial year was therefore at the same level as in the previous year and at the same time slightly lower than the 2011 benchmark (398.1 kg).

WASTE. We try to reduce the amount of waste caused by our production process as far as possible. Most unavoidable waste is recycled. Only when we have exhausted these means do we dispose of the remaining waste in an environmentally compatible way. Fortunately, the total amount of refuse generated by H&R's refinery sites is in any case low. By way of comparison, in 2014 we once again reduced the amount of waste we pro-

duce substantially, by approximately 33% compared to the benchmark year of 2011 (3.09 kg). However, instead of 1.59 kg per ton of feedstock, we generated 2.08 kg per ton during the past financial year.

WATER USE. Most of the water required for our refineries is used for cooling. This water does not come into contact with our products and can be returned directly to the environment. Our closed-circuit systems enable us to use our cooling water several times in some cases, thereby reducing our overall water consumption. A very small proportion of the water is used directly in our refinery processes. We use sophisticated procedures to purify this water so that it can be returned to the environment as wastewater without any concerns. In total, in 2014 we drained off 604.7 liters of domestic or process wastewater per ton of feedstock, thus performing well below our 2011 benchmark (861.2 liters). In the prior year, the comparative quantity was markedly higher yet, at 679.5 liters.

## Product responsibility

At all the sites in the Group, we strive to have uniform safety standards that exceed statutory requirements. In doing so, we take the entire value chain into consideration: from the delivery of raw materials to the use of our components in our customers' products.

Our product safety approach is based on our system of material safety data sheets. This system gives our employees and customers around the world access to key health, environmental and safety information about our products. Our database currently holds more than 2,000 material safety data sheets (MSDS) in 18 languages. These data sheets are constantly being expanded and updated. This approach ensures that – provided that they are used properly – our products do not entail any risks to people or the environment.

We apply the standards laid down in REACH, the new EU regulation for chemicals. In 2010, we successfully completed the relevant registration phase for substances with an annual production volume of more than 1,000 tons. During the period under



**Non-financial performance indicators**  
General economic outlook

review, we incorporated the additional information required by the regulation into our material safety data sheets. In order to keep the costs of complying with REACH to a minimum and to take advantage of synergies, we play an active role in the CONCAWE association. At the local level, we also joined REACH's network of experts in Hamburg.

Now that registration has been completed successfully, some of the substances we produce require authorization. No costs were incurred for this in the 2014 financial year, however.

#### Supplier and customer relations

**SUPPLIER RELATIONS.** The main feedstocks processed by our refineries in Hamburg and Salzbergen are long residue (ATRES) and vacuum gas oil (VGO), derivatives that are produced when crude oil is processed at fuel refineries. The main suppliers of our raw materials are the major oil companies. We sign volume contracts with suppliers from different regions for a period of up to twelve months to reduce the risk of supply shortages. In order to diversify our sourcing even further and to benefit from short-term price fluctuations, we purchase additional quantities on the spot market.

The Plastics Division uses many types of plastic granulate and various metals as 'inserts'. In many cases, our customers determine the materials and the supplier to be used for a given order themselves. We therefore normally bear joint responsibility, together with our customers, for sourcing raw materials.

No supply shortages occurred during the reporting period. We are not dependent on individual suppliers.

**CUSTOMER RELATIONSHIPS.** Hansen & Rosenthal KG currently handles the sales and distribution of a large part of the products from our Chemical-Pharmaceutical Division. Our sales/distribution partner has been trading in crude-oil-based specialty products for over 90 years. Thanks to its long-established market presence, Hansen & Rosenthal has excellent market knowledge and close customer contacts. In our Plastics Division, the correlation to the performance of the automotive industry increased further in 2014: customers from this market segment accounted for 71% of

sales revenues during the period under review, compared with 66% the previous year. The industrial segment in particular, where we primarily manufacture products for customers in the electrical, measuring and control technology segments, was not able to maintain its revenue share, which declined from 17% to 19%. The share of revenues from customers in the medical technology segment was stable, at a low level.

## General economic outlook

### Assessment of the economic situation by company management

Over the reporting period, the economic situation at H&R AG unfolded differently than the Executive Board had assumed at the beginning of 2014. In particular, the target figures for sales revenues and EBITDA were corrected during the year. Nevertheless, we once again posted good revenues, primarily because the lower revenues did not indicate any problems relating to quantities or demand, but instead resulted almost completely from the reduction in prices for raw materials.

At €31.5 million, earnings (EBITDA) were lower than in the previous year solely because of the significant "windfall losses" in the last quarter of 2014. Adjusting for this effect, from an operating standpoint, it is clear from the company's higher margin that it is headed in the desired direction.

After seeing only single-digit contributions to full-year operating income (EBITDA) during the first two quarters of 2014, the company gained considerable momentum in the third quarter. However, this cannot be explained by improved market conditions alone: at the turn of the year from 2013 to 2014, the Executive Board introduced a comprehensive package of measures in order to take control of and sustainably reinforce the earnings situation by adapting the company's process flows, product portfolio, cost structure and the strategic direction of the business as needed. The quick change in course by the Hamburg refinery – the result of pressure on prices for by-products – and the sustainable improvement in the ratio of primary products to by-products that resulted is proof of H&R AG's high degree of flexibility.



Further optimizing our smart raw materials management system and achieving internal synergies within the H&R Group were important strategic milestones for ensuring the company's future viability. We now have the ability to analyze samples of raw materials virtually overnight, to determine the "intrinsic value" and to adjust our refineries to produce the products for which there is market demand.

At the same time, we believe that the conclusion of last year's refinery study by Solomon Associates, which rated our refinery sites in Salzbergen and Hamburg as well positioned in comparison to their well-known global competitors in the lubricant refineries sector, will continue to apply in 2014. Numerous Group 1 base-oil production sites – including major groups' refineries – are leaving the market. It is not only our aforementioned flexibility that enables us to hold our ground. H&R's refineries have an above-average share of high-grade petroleum-based specialty products, waxes and white oils, while our share of lower-margin lubricants is below the market average.

Finally, H&R AG has succeeded in strengthening its international business thanks to the contributions from its operations in China – and not just in volume, but above all in the realm of specialty products.

Overall, therefore, we believe the company is significantly more stable than it was even a year ago. In view of the difficult market and macroeconomic conditions, the measures implemented were necessary and appropriate to positively influence the company's earnings trend. In spite of everything we have achieved, we must rigorously adhere to the course upon which we have embarked.

#### Presentation of the influence of financial policies on the economic situation

As in prior years, we have been conservative in exercising discretion and in making estimates. Our net assets and financial position also reflect, inter alia, the steps we have taken to manage working capital (factoring, inventory management, advance payments for orders). For a full description of the assumptions and discretionary decisions made with respect to the measurement of assets and liabilities, please refer to the presentation in the [notes](#) to the consolidated financial statements in this annual report.



For further information see page 105 ff.

## Earnings, financial and asset position of H&R AG

### T.28 EARNINGS POSITION OF H&R AG UNDER HGB

IN € THOUSAND	2014	2013	Change
Sales revenues	1,079	1,399	-320
Other operating income	1,743	3,949	-2,206
Personnel expenses	-1,658	-2,460	802
Amortization of intangible fixed assets and depreciation of property, plant and equipment	-20	-21	1
Depreciation and amortization of current assets in excess of the company's customary depreciation and amortization charges	-20,000	0	-20,000
Other operating expenses	-6,012	-7,349	1,337
Income from equity investments	123	0	-123
Income from profit-transfer agreements	708	271	437
Expenses from loss-transfer agreements	-25,714	-18,734	-6,980
Income from lending financial assets	5	7	2
Other interest and similar income	10,665	12,873	2,208
Interest and similar expenses	-9,462	-12,984	3,522
<b>Earnings/(loss) before taxes from ordinary operations</b>	<b>-48,542</b>	<b>-23,048</b>	<b>-25,494</b>
Extraordinary expenses	-53	-53	0
Extraordinary result	-53	0	-53
Income taxes	-52	45	-97
Other taxes	-1	-1	0
<b>Net loss for the year</b>	<b>-48,648</b>	<b>-23,057</b>	<b>-25,591</b>
Loss carryforward	-42,450	-19,393	-23,057
<b>Accumulated deficit</b>	<b>-91,098</b>	<b>-42,450</b>	<b>-48,648</b>

We have prepared the separate financial statements for H&R AG in accordance with the German Commercial Code (HGB). They are published in the Federal Gazette [Bundesanzeiger] and are permanently available for downloading from the H&R AG section of the company website, [www.hur.com](http://www.hur.com). For financial year 2014, we have combined the management reports of the H&R Group and of H&R AG.



[www.hur.com](http://www.hur.com)

H&R AG's revenues are generated solely by services rendered to companies in the Group. At €1.1 million, sales revenues were slightly lower than in the prior year (2013: €1.4 million). Personnel expenses of €1.7 million were lower than in the prior-year period (2013: €2.5 million). The fixed-asset depreciation charge of €20,000 was almost identical to that of the previous year (€21,000). However, in the Plastics segment, a bad-debt expense of €20.0 million was recognized and affected H&R AG's earnings accordingly.

Other operating expenses decreased slightly, from €7.3 million to €6.0 million. A significant change (in the amount of €20.0 million) in the deprecia-

tion and amortization of current assets was related to the write-off of a receivable due from our subsidiary GAUDLITZ GmbH.

The trend in income from profit-transfer agreements was somewhat better, increasing from €0.3 million in 2013 to €0.7 million in 2014. The increase is related to improved earnings from subsidiaries in the ChemPharm Refining, Sales and Plastics segments.

The generally strained earnings situation at some subsidiaries with which individual profit-transfer agreements exist was also the main reason for the rise in expenses from loss-transfer agreements from €18.7 million the year before to €25.7 million in the reporting period. The subsidiaries of H&R AG obtain funding for their financing needs from H&R AG's resources, which in turn are financed on the capital markets via credit lines and borrower's note loans. On the one hand, our other interest and similar income declined slightly, from €12.9 million to €10.7 million. On the other hand, lower financing costs had a significant effect in 2014, reducing interest and similar expenses from €13.0

million to €9.5 million. Those items were higher in 2013 due to waiver fees. Overall, the loss before taxes from ordinary operations reached €-48.5 million (previous year: €-23.0 million).

Taxes decreased from €45,000 in the prior-year period to €-52,000. Overall, H&R AG reported

a net loss for the year of €48.6 million (previous year: a net loss of €23.1 million). Accordingly, once again no retained earnings were booked. The net loss for the year was recognized in full as accumulated deficit. Our result does not allow for a dividend distribution.

#### T.29 NET ASSETS AND FINANCIAL POSITION OF H&R AG

IN € THOUSAND	2014	2013	Change
Intangible assets	-	-	-
Land, land rights and buildings, including structures on third-party land	9	9	0
Other equipment, operating and office equipment	90	106	-16
<b>Property, plant and equipment</b>	<b>99</b>	<b>115</b>	<b>-16</b>
Shares in affiliated companies	119,688	76,714	42,974
Loans to affiliated companies	52,312	57,617	-5,305
Equity investments	1,050	1,050	0
Loans to entities in which the company has a participating interest	100	138	-38
<b>Financial assets</b>	<b>173,249</b>	<b>135,519</b>	<b>37,730</b>
Receivables due from affiliated companies	104,242	116,447	-12,205
Other assets	3,554	374	3,180
<b>Receivables and other assets</b>	<b>107,796</b>	<b>116,821</b>	<b>-9,025</b>
<b>Securities</b>	<b>163</b>	<b>297</b>	<b>-134</b>
Bank balances	28,206	78,711	-52,505
<b>Current assets</b>	<b>136,165</b>	<b>195,829</b>	<b>-59,664</b>
<b>Prepaid expenses</b>	<b>430</b>	<b>519</b>	<b>-89</b>
<b>Assets</b>	<b>309,843</b>	<b>331,982</b>	<b>-22,139</b>
Subscribed capital	91,573	76,625	14,948
Capital reserve	56,037	31,225	24,812
Other retained earnings	29,866	29,866	0
Accumulated deficit	-91,098	-42,451	-48,647
<b>Shareholders' equity</b>	<b>86,377</b>	<b>95,265</b>	<b>-8,888</b>
Provisions for pensions and similar commitments	2,316	2,646	-330
Tax provisions	0	1,165	-1,165
Other provisions	8,240	9,157	-917
<b>Provisions</b>	<b>10,556</b>	<b>12,968</b>	<b>-2,412</b>
Liabilities to banks	165,840	178,422	-12,582
Trade accounts payable	253	196	57
Liabilities to affiliated companies	43,661	38,140	5,521
Other liabilities	3,156	6,991	-3,835
Liabilities	212,910	223,749	-10,839
<b>Shareholders' equity and liabilities</b>	<b>309,843</b>	<b>331,982</b>	<b>-22,139</b>

H&R AG's total assets fell by 6.7% to €309.8 million as of 31 December 2014 (31 December 2013: €332.0 million). Because of the contribution of the Chinese businesses, shares in affiliated companies increased significantly, from €76.7 million to €119.7 million, while loans to affiliated compa-

nies decreased considerably, from €57.6 million to €52.3 million. This decline is largely due to loan repayments made by our subsidiaries. Overall, financial assets increased from €135.5 million at year-end 2013 to €173.2 million.

## Earnings, financial and asset position of H&amp;R AG

Receivables due from affiliated companies fell from €116.4 million to €104.2 million due to lower earnings at subsidiaries with which profit- and loss-transfer agreements are in place.

Bank balances dropped substantially from €78.7 million to €26.2 million as of the reporting date.

All in all, current assets decreased by 30.4%, from €195.8 million to €136.2 million.

During the financial year, subscribed capital was increased through the issuance of 5,847,042 ordinary shares for €14.9 million; as of the balance sheet, it totaled to €91.6 million, divided into 35,820,154 ordinary shares (previous year: 29,973,112 ordinary shares). At the same time, additional paid-in capital (capital reserves) increased by €24.8 million, from €31.2 million to €56.0 million.

The full amount of the net loss incurred in the reporting period, €48.6 million, was recognized in

the accumulated deficit, which therefore reached €91.1 million at year-end. Shareholders' equity contracted from €95.3 million as of 31 December 2013 to €86.4 million at the end of the reporting period. The equity ratio decreased to 27.9% (31 December 2013: 28.7%).

Due to lower provisions for pension commitments and the reversal of tax provisions, this item decreased from €13.0 million in 2013 to €10.6 million in 2014.

Liabilities fell by a substantial 4.8% to €213.0 million (31 December 2013: €223.7 million) and accounted for 68.7% of total liabilities and shareholders' equity, compared with 67.4% the previous year, as the total liabilities and shareholders' equity figure was lower.

An increase in liabilities to affiliated companies from €38.1 million to €43.7 million was offset by a €12.6 million drop in liabilities to banks.

**Other statutory disclosures**

Disclosures in accordance with Art. 289 para. 4 and Art. 315 para. 4 of the German Commercial Code (HGB)

## Other statutory disclosures

### Disclosures in accordance with Article 289, paragraph 4 and Article 315, paragraph 4 of the German Commercial Code (HGB)

#### Item 1: Composition of subscribed capital.

As of 31 December 2014, H&R AG's subscribed capital (share capital) was unchanged at €91,572,769.63. It is divided into 35,820,154 no-par bearer shares. This corresponds to a notional value of €2.56 per share. There are no different classes of shares; they are all ordinary shares. Each of these shares entitles the holder to one vote.

#### Item 2: Restrictions on voting rights or the transfer of shares.

The Executive Board of H&R AG is not aware of any restrictions affecting voting rights or the transfer of shares.

#### Item 3: Direct or indirect interests exceeding ten percent of voting rights.

According to the notification from Mr Nils Hansen dated 26 September 2014, his share of voting rights, held by H&R Beteiligung GmbH and attributable to Mr Nils Hansen via H&R Holding GmbH, was 41.89% on 25 September 2014 and therefore was below the 50% threshold on that date. According to an informal announcement on 11 December 2014, H&R Beteiligung GmbH's stake rose by another 1.11%.

According to another notification from Mr Nils Hansen dated 26 September 2014, his share of voting rights, held by H&R Internationale Beteiligung GmbH and likewise attributable to Mr Nils Hansen, exceeded the 15% threshold on 25 September 2014 and amounted to 16.32% on that date.

According to an informal notification, the equity interest attributable to Mr Hansen came to 60.28% on 31 December 2014. Of this total, 0.96% is attributable to Mr Hansen as privately held voting rights.

#### Item 4: Holders of shares with special rights granting powers of control.

There are no shares with special rights granting powers of control.

#### Item 5: Control over voting rights of shares held by employees.

The voting rights of employees who hold shares in the company's capital are not controlled.

#### Item 6: Statutory regulations and provisions of the Articles of Association on the appointment and dismissal of Executive Board members and amendments to the Articles of Association.

The Supervisory Board oversees the Executive Board and advises its members on the management of the Company. Executive Board members are appointed and dismissed in accordance with Articles 84 and 85 of the German Stock Corporation Act (AktG). Amendments to the Articles of Association are made on the basis of Articles 133 and 179 AktG and Article 20, paragraph 2 of the Articles of Association. The Supervisory Board is nevertheless entitled to adopt amendments to the Articles of Association that only affect their wording without the approval of the Annual Shareholders' Meeting. Article 13 of the Articles of Association defines further circumstances, in addition to those defined by statute, in which the Supervisory Board's approval is required. Specifically, these are: entering into long-term liabilities, establishing and dissolving branch offices and establishing, liquidating, merging or converting subsidiaries. The Supervisory Board has also adopted rules of procedure as recommended in Section 5.1.3 of the German Corporate Governance Code.

#### Item 7: Powers of the Executive Board, particularly regarding the issuance or buyback of shares.

The Executive Board has various options for implementing corporate actions. Pursuant to Article 4, paragraph 4 of the Articles of Association, the Executive Board is authorized – with the Supervisory Board's approval – to increase the company's share capital by 12 May 2019 by a maximum of €22,364,796.53 by issuing up to 8,748,348 ordinary no-par bearer shares. The issue may be effected in one or more tranches in return for cash and/or contributions-in-kind (2014 Approved Capital). In principle, the shareholders have a subscription right. The new shares may also be acquired by one or more banks with the obligation to offer them for subscription to shareholders. Subject to the approval of the Supervisory Board, the Executive Board is entitled to suspend

**Other statutory disclosures**

Disclosures in accordance with Art. 289 para. 4 and Art. 315 para. 4 of the German Commercial Code (HGB)

shareholders' subscription rights on one or more occasions,

- a) to the extent necessary to exclude fractional share amounts from shareholders' subscription rights;
- b) to the extent necessary to grant holders of option or conversion rights and/or obligations under warrants or convertible bonds the same rights to subscribe new shares that they would have as shareholders if they had already exercised their option or conversion rights or fulfilled their conversion obligations;
- c) to the extent that the new shares are issued for subscription in cash and the proportion of share capital attributable to the new shares does not exceed the lesser of €7,662,503.90 or 10% of share capital at the time this authorization to exclude subscription rights takes effect and is exercised for the first time ("maximum amount") and the issue price of the new shares is not significantly lower than the quoted price for company shares of the same type already listed on the stock exchange at the time the issue price is set definitively;
- d) to the extent that the new shares are issued in exchange for contributions-in-kind, especially in the form of companies, parts of companies, interests in companies or receivables.

The maximum amount defined in Article 4, paragraph 4c of the Articles of Association is to be reduced by the proportion of share capital attributable to new or previously acquired treasury shares that have been issued or sold since 13 May 2014 on the basis of a simplified exclusion of subscription rights in accordance or by analogy with Article 186, paragraph 3, sentence 4 AktG, and by the proportion of share capital attributable to shares that can be acquired through option or conversion rights and/or obligations that have been issued since 13 May 2014 by analogous application of Article 186, paragraph 3, sentence 4 AktG. Any reduction is reversed to the extent that authorizations to issue convertible bonds and/or bonds with warrants in accordance with Article 221, paragraph 4, sentence 2 and Article 186, paragraph 3, sentence 4 AktG or to sell treasury

shares in accordance with Article 71, paragraph 1, no. 8 and Article 186, paragraph 3, sentence 4 AktG or to issue new shares in accordance or by analogy with Article 186, paragraph 3, sentence 4 AktG are granted again by the Annual Shareholders' Meeting once the authorizations that resulted in the reduction have been exercised.

The Executive Board is authorized, with the approval of the Supervisory Board, to specify the further details about the capital increase, in particular details regarding the rights accruing to the shares and the terms of issue. Once the increase in share capital has been fully or partly completed, the Supervisory Board is authorized to revise Article 4 of the Articles of Association based on the utilization of the approved capital from time to time and once the authorization period has expired.

The Executive Board is also authorized until 30 May 2016 – with the Supervisory Board's approval – to increase the company's share capital by up to €1,000,000.00 by issuing no-par ordinary bearer shares on one or more occasions for subscription in cash for the purpose of issuing employee shares to staff of the company and its affiliated companies (2011 Approved Capital). Shareholders' subscription rights are precluded in this case.

The Supervisory Board is authorized to revise Article 4, paragraph 5 of the Articles of Association once the share capital increase has been fully or partially completed or the authorization period has expired.

In financial year 2014, the Executive Board exercised these powers in its 17 September 2014 decision – with the Supervisory Board's approval – to carry out an increase in contributions-in-kind from the approved capital, while barring existing shareholders' subscription rights. In the process, the Hansen & Rosenthal Group, Hamburg, contributed 51% of its China businesses, which were combined into H&R China Holding GmbH, Hamburg, to H&R AG as a contribution-in-kind in exchange for the issuance of new shares. H&R AG undertook to grant 5,487,042 new shares as consideration for the equity interest it was to receive in the Hansen & Rosenthal Group. This cap-

ital increase in the form of a contribution-in-kind was recorded in the Commercial Register on 25 September 2014. However, until they have been admitted for listing, these 5,847,042 newly issued shares cannot be traded on the stock exchange. The increase in contributions-in-kind from the approved capital increased the company's share capital by €14,947,725.52 to €91,572,769.63, in part by utilizing the approved capital by issuing 5,847,042 new no-par bearer shares.

In addition, the resolution passed by the Annual Shareholders' Meeting on 27 May 2010 authorized the company to acquire treasury shares in the period until 26 May 2015 of up to 10% of existing share capital at the time the resolution was passed. Together with other treasury shares held by the company or attributable to it under Article 71a et seq. AktG, the treasury shares acquired under this authorization may not exceed 10% of the company's share capital at any point in time.

Treasury shares may not be acquired for trading purposes. The authorization can be exercised in whole or in part, once or several times, for the purpose of pursuing one or several objectives, either by the Company, by its consolidated companies or by third parties for the benefit of the Company or its consolidated companies.

At the discretion of the Executive Board, the acquisition may be made via the stock exchange or by way of a public purchase offer to all shareholders or by way of a public request to make such an offer. The details of the authorization can be found in the proposed resolution by the Executive Board and Supervisory Board published to accompany item 5 of the agenda for the Annual Shareholders' Meeting held on 27 May 2010, which will be sent by mail on request.

There was no share buyback program last year.

#### Item 8: Essential agreements subject to the condition of a change in control owing to a takeover bid.

The banks involved in the syndicated loans and borrower's note loans have the right to call in the loans in the event of a change of control.

#### Item 9: Compensation agreements to be concluded with the members of the Executive Board or with employees covering the eventuality of a takeover bid.

No such arrangements exist at this time.

### Subordinate status report (Related-party transactions)

Since late 2010, the percentage of voting rights attributable to Mr Nils Hansen has exceeded 50%. Mr Nils Hansen regularly had a de facto voting majority in prior years too. As a result, we produce a subordinate status report each year in accordance with Article 312 AktG.

In the report for the 2014 financial year, our Executive Board came to the following conclusion: "With regard to the transactions listed in the Report on Relationships with Affiliated Companies for the reporting period from 1 January 2014 to 31 December 2014, based on the circumstances that we were aware of at the time such transactions took place, our company received appropriate consideration for every transaction. No relevant measures were implemented or omitted during the reporting period."

## Key events following the balance sheet date

Effective 1 January 2015, H&R AG sold two parcels of land from the portfolio of SYTHENGRUND WASAGCHEMIE Grundstücksverwertungsgesellschaft Haltern mbH. The company reported a gain of €295,000 on the properties, which were formerly used in connection with the production of explosives.



## Forecast report

### Orientation of the Group in financial year 2015

Statements concerning short-term company trends from 1 January to 31 December of financial year 2015 assume that, based on our current knowledge, there will be no fundamental legal or organizational changes in the structure of the Group.

The main challenge facing our company is how to deal with the trade-off between raw-material prices and market conditions. H&R AG is positioned so that it can actively take advantage of its flexibility at three different levels of the value chain: as a refinery operator and producer, in further processing and in distribution. If, in addition to our in-house expertise, we also need external capacity, we arrange this with our network of tried and tested partnerships. Every one of our Group subsidiaries fits into this simple matrix.

At the same time, we need to take goal-oriented, individually tailored steps to achieve our 2015 targets.

We will prepare our Chemical-Pharmaceutical Refining business – which as one of our core competencies was the main driver of total revenue growth during the reporting period – to tackle future challenges through constant modernization and expansion efforts. Above all, this applies to the efficiency and degree of vertical integration at our refineries. Here, we have instituted measures designed to more clearly highlight the market-driven influences on our business that are only partly within our control while at the same time increasing the level of certainty for medium-term corporate planning. This should minimize the adverse effect of these volatile factors on our earnings accordingly. For the Salzbergen site, this means continuing the contract-production model, which adds stability and planning predictability to our forecasts for sales revenues and earnings in 2015.

In our view, the Hamburg refinery's performance is by far the strongest lever we have for optimizing our results. The important groundwork has already been done and proven to be both effective and successful in 2014. Here, we will focus primarily on the following issues:

- Optimizing management of raw materials
- Reducing/marketing by-products

Continuing to integrate the sites and to take advantage of internal Group synergies will enable us to optimize fixed costs at the corporate (AG) level.

The use of higher-value raw materials as a reaction to the weak pricing situation for by-products at the start of the year has already proven to be effective. Over the course of the year as a whole, we managed to significantly reduce the percentage of by-products. In 2015, we will again redouble our efforts to find solutions for the ideal selection and use of raw materials and to expand our expertise in order to improve this cost item.

In the Chemical-Pharmaceutical Sales segment, our strategy of forming production partnerships to supplement our own blending and conversion plants has proven to be successful. The takeover of the Hansen & Rosenthal Group's profitable Chinese business has strengthened our international business. At the same time, it adds a new growth engine to help us penetrate the international specialty-products business.

For the Plastics segment, the goal is to reduce dependence on the automotive industry by expanding the division's activities in the fields of medical, electrical, measurement and control technology and to operate the business profitably over the next few years with customary market returns.

Moreover, all areas of the organization are being asked to examine their own positions and to contribute to a financially quantifiable optimization of all processes wherever possible and necessary.

**Forecast report**

Orientation of the Group in financial year 2015

**Future sales markets**

In the Chemical-Pharmaceutical business, Germany and other European countries will continue to be the main drivers of our sales revenues. In view of the maturity of these markets, our growth strategy in this region is based less on increasing volumes than on improving the efficiency of production processes and manufacturing higher-quality products. At the same time, we intend to continue to benefit from our products' broad range of applications in over 100 different industries.

Outside of Europe, by expanding our business to include China, we are quite clearly focusing now on Asia and – as planned – we have increased the percentage of total revenues contributed by the international side of our business. China is also a bridgehead for our goal of establishing a strong presence in the growing international market for specialty products. Our businesses concentrate primarily on the production and marketing of wax products and label-free plasticizers for the tire industry. The significance of this market will increase substantially with the relocation of many tire manufacturers from Europe to China.

Throughout the entire region of East Asia, we want to participate in the growth projected for these emerging markets, both by accelerating the expansion of our existing sales activities and by forming new production partnerships.

**Future use of new technologies and processes**

Constantly improving processes to increase efficiency and raise product quality is a core element of our corporate strategy.

By operating new equipment at our facilities, we increase the value added by our domestic refineries. This enables us to convert products previously not capable of being refined into high-grade crude-oil-based specialty products and to minimize the amount of waste residue left over by the production process. In the Plastics Division, too, we work continuously to improve our production processes.

**Future products and services**

In the future, we will continue to pursue our successful strategy of developing innovative products that are closely aligned with our customers' needs. In the Chemical-Pharmaceutical Division, our sales partner, Hansen & Rosenthal KG, serves as an interface between our customers and our R&D departments. By constantly testing new product specifications, we aim to have our input materials contribute to further efficiency gains in our customers' production processes and further increase the quality of their products. One of the focal points of our research and development activities is to ensure the continued diversification of our primary products. We are already developing the next generation of these products in order to maintain our technological lead in this field. Work is also under way to develop innovative processes for manufacturing white oils and other crude-oil-based specialty products.

The Plastics Division reflects the expansion of our customer base in the medical technology sector and a closer focus on our customers in the automotive segment: the performance-oriented reorganization of our processing and operating processes will enable us to significantly improve results over the medium term.

**Comparison of actual and target figures**

The following table compares the actual values of the main or key control figures used by H&R AG for the past financial year (FY) with the original forecast and shows the outlook for financial year 2015:

## T.30 COMPARISON OF ACTUAL VALUES WITH FORECAST

KEY FIGURE/FINANCIAL RATIO	Forecast FY 2014	Actual FY 2014	Outlook FY 2015
Group sales	€1,100 million to €1,200 million	€1,058.6 million	€1,000 million to €1,100 million
of which Chem.-Pharm. Raw Materials Refining*	72%	€768.7 million	60%
of which Chem.-Pharm. Raw Materials Sales*	23%	€244.7 million	34%
of which Plastics	5%	€56.5 million	6%
Reconciliation	N/A	€-11.3 million	N/A
Consolidated EBITDA	€40 million	€31.5 million	€45 million to €65 million
of which Refining*	66%	€18.2 million	56%
of which Sales*	31%	€18.8 million	42%
of which Plastics*	3%	€-1.5 million	2%
Transfer	N/A	€-3.9 million	N/A
Net indebtedness	€110 million	€107.3 million	

\* The sales and earnings forecasts for the individual segments are stated as a percentage distribution because of the ranges (sales) or approximations (earnings).

For the main indicator, sales revenues by segment, the company failed to reach the projected level because of the decline in raw-material costs, which are the primary driver of sales revenues. In the ChemPharm Sales segment, we expect sales volumes to increase substantially; this is reflected in the fact that the 2015 forecast is the same as the prior-year level, despite the fact that raw-material costs are expected to remain low.

The projected figure for operating income (EBITDA) was likewise missed. Here, the higher earnings forecast primarily reflects potential in the international business. Above all, we expect the takeover of the Chinese businesses to contribute to higher earnings; this year, only €2.0 million of EBITDA from the fourth quarter was included.

Higher earnings would leave us scope for higher debt. At the end of financial year 2015, net debt is expected to be €128.8 million. On the balance-sheet date, it stood at €107.3 million (31 December 2013: €73.1 million).

## Economic environment in the next financial year

## Future macroeconomic situation

Recently, global economic prospects have been adjusted downwards repeatedly. According to a forecast by the Kiel Institute for the World Economy [Institut für Weltwirtschaft] (IfW), global gross domestic product will grow by 3.7% in 2015, i.e., noticeably more than during the reporting period (2014: 3.2%). Experts expect economic output in

## G. 13 GLOBAL ECONOMIC GROWTH FORECAST

IN %, SOURCE: IWF

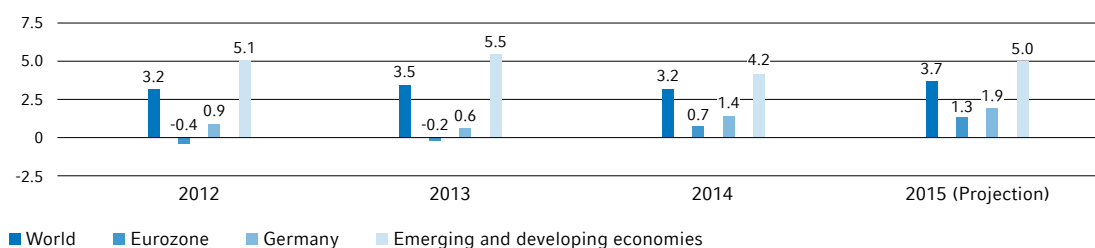

**Forecast report**

Expected results of operations by segment

the Eurozone to increase by 1.3% (2014: 0.7%). With expected GDP growth of 1.4% in the current year and 1.9% in 2015, Germany should, in the opinion of the IfW, be able to once again overtake the other countries in the Eurozone.

Economic researchers at the Kiel Institute are again forecasting higher economic growth rates in the ASEAN-5 countries – which are of great importance to H&R AG – after economic growth slowed to 4.2% during the past year. For this economic zone, comprising Indonesia, Malaysia, the Philippines, Thailand and Vietnam, average GDP is expected to grow by 5.0% in 2015. In particular, experts foresee a substantial economic expansion for Thailand.

Our budget for financial year 2015 is based on a USD-EUR exchange rate which we have set below the prior year's actual average exchange rate of 1.33, in line with the rate in effect at the beginning of 2015. For crude-oil prices, we also rely largely on the estimates published by the economics departments of major banks. For the budget year 2015, we assumed a price of USD 60.00 per barrel for North Sea Brent.

**Future state of the sector**

The German Chemical Industry Association [Verband der Chemischen Industrie/(VCI)] is cautiously optimistic about the future and expects total production to exceed that of 2014 by 1.5%. Companies in the industry also expect sales revenues to improve accordingly and are expecting an increase of around 1.5%. On the other hand, the Association has a more critical view of price trends for chemical products: losses of around 0.5% bear witness to new strains in the market.

Likewise, in the Chemical-Pharmaceutical Division, the shortage of production capacity for specialty products continues. In 2015-2016 alone, around one-fifth of current capacity could disappear entirely from the market or see substantial reductions. Because of the macroeconomic conditions, this fundamentally positive development to date has been more than offset by the decline in demand.

Over the next few years, we expect the highly fragmented plastics industry to consolidate

through mergers and takeovers. Especially in the battle over the automotive industry – a major customer – only those companies capable of manufacturing high-quality products dependably and efficiently will prevail. The medical technology industry is another sector that is gaining in importance as a customer, thanks to technological progress and demographic trends.

**Expected results of operations by segment****Forecast revenue trends**

Our revenue is affected considerably by the cost of raw materials for our Chemical-Pharmaceutical Division, which we pass on to our customers through our product prices. The price of our most important raw material, long residue, is closely correlated with the price of crude oil. If our planning assumptions for crude-oil prices and the US dollar/euro exchange rate prove correct, we anticipate that prices for raw materials and products will remain constant overall.

Our 2015 forecast of sales revenues is based on the assumption of a lower crude-oil price; however, we expect higher sales volumes in the ChemPharm Sales segment to boost our sales revenues considerably. This potential includes, among other things, the contribution from China. Overall, we expect 2015 consolidated sales revenues to be at the same level as in 2014. The ChemPharm Refining segment will contribute approximately 60% of revenues. The Sales business will contribute a larger portion – around 34% – than last year, thanks to the effect of the takeover in China. The Plastics Division will contribute around 6%.

**Expected earnings trends**

In terms of demand and volumes of primary products sold Group-wide, results for the past financial year were uneven, but at the same level as in the previous year overall. Due to the “windfall losses”, operating income stood at €31.5 million – below the previous year and our expectations.

The contract-production model initiated over 18 months ago to stabilize earnings has proven to be the correct strategy, and one that we will continue

to pursue for the time being. At the same time, the past year made us aware of the fact that, in spite of generally more positive statements by economic experts, H&R AG still continues to face significant challenges in its specific markets. Therefore, again in 2015, results of operations will not improve simply by waiting for better economic conditions. Rather, the company must redouble its own efforts and implement its own solutions to find a speedy way out of the current situation.

We believe that the main ways to improve earnings performance in 2015

lie in optimizing the three pillars for value creation: purchasing, production and sales/distribution in the ChemPharm Refining segment.

Here, raw materials management is by far the major driver for improving the earnings situation. Our added value and our margins are already affected by the raw materials we use as inputs at our plants. Their composition has direct consequences on the output and thus on the ratio of lucrative primary products to lower-margin by-products. We are deliberately controlling the procurement of raw materials with this in mind: more effective raw materials that yield a higher percentage of primary products need to be identified and valued more accurately.

To achieve this, we are also focusing on improving our refinery and production processes and more aggressively marketing the remaining share of by-products.

In line with our international expansion strategy, the inclusion of the Chinese businesses will increase the contribution to earnings by the higher-margin international specialty-products business. The Asian region is enjoying higher growth rates than other regions. We assume that we will benefit from this trend through continued positive EBITDA contributions.

Our expectations reflect a significantly lower Brent price than at the beginning of 2014, based on the trend in the price of crude oil at the end of 2014. At the same time, we consider the negative impact on earnings caused by the “windfall loss-

es” described in this annual report to have been realized. Even though we are not assuming a similar effect for 2015, we have already included a further decrease in the price in our earnings forecast.

Overall, we are expecting consolidated operating income (EBITDA) of between €45.0 million and €65.0 million in 2015. The earnings contribution from our ChemPharm Refining segment will make up approximately 56% of this amount. The international business will account for approximately 42%. The Plastics Division should contribute around 2% to the Group’s operating income (EBITDA).

#### Expected trends in the main income-statement items

After the conversion of the refinery in Salzbergen to contract processing in financial year 2013 and the inclusion of the Chinese businesses in 2014, no structural changes to the income statement are expected for 2015.

### Expected financial position by segment

#### Planned financing activities

We are not currently planning to raise any additional equity capital. However, the Annual Shareholders’ Meeting of H&R AG has empowered the company to increase the share capital in exchange for cash or contributions-in-kind, so that corporate actions will also be a possibility when reviewing strategic options.

H&R AG has concluded various loan agreements and borrower’s note loans with banks. The main pillars of our Group financing arrangements are borrower’s note loans totaling €116.0 million and a syndicated loan for up to an additional €72.5 million. There is also a €50.0 million environmental loan from KfW [Kreditanstalt für Wiederaufbau/ Reconstruction Credit Corporation].

Various financial covenants have been agreed for the borrower’s note loans and the syndicated loan. The payments due in 2016 on the 5-year tranche of the borrower’s note loan, which may need to be refinanced, total €63.0 million. For the syndicated loan, the amount is €72.5 million.

**Forecast report**

Expected financial position by segment



For further  
information see  
page 60

For more information on our main financing instruments, please refer to the section “Financial management principles and objectives” on page 60 of this report. The activities described there will make a major contribution to reducing our financing requirements.

**Expected liquidity trend**

In light of the financing adjustment implemented at the end of 2013 and finalized in February of 2014, we do not see a need for further structural changes for 2014. Thanks to the available credit lines under our syndicated loan, we have sustainable access to sufficient liquidity for the years ahead.

**Planned investments**

After several years of moderate capital expenditures, we are planning to increase our investments on maintenance and modernization of our facilities during the current financial year. Around 84% of capital expenditures will be in the ChemPharm Refining segment.

Around 7% of the expenditures will be in the Sales segment and another 7% will go towards investments in the Plastics Division and on other items. Together with other measures intended to increase the efficiency and cost-effectiveness of our production processes, our capital expenditures will exceed our ordinary depreciation and amortization charges.

# Risk report

## Risk policy

H&R AG's business policy is aimed at increasing the value of the company over the long term. In order to achieve this, we must seize market opportunities while carefully weighing the associated risks.

The goal of our risk policy is to optimize the relationship between risks and opportunities while avoiding risks that could jeopardize the company's continued existence as a going concern. Systematic risk management is the direct responsibility of the Executive Board. Risks are generally identified and communicated by the managing directors of the respective local operating units. As far as possible, risks are eliminated or otherwise addressed at a local level.



As a manufacturer of crude-oil-based specialty products, we have a particular responsibility to operate our refineries in a way that protects both people and the environment. All our production sites therefore have officers who actively work to ensure the safety of our employees and our facilities while protecting the environment.

## Risk management system

The risks to which H&R AG and its subsidiaries are exposed are identified, assessed, communicated and limited or eliminated, as appropriate, across the entire Group in a uniform manner. We use various methods to identify risks, such as monitoring industry-specific and macroeconomic risk indicators and analyzing purchasing and sales markets.

The identification of risks is considered to be the responsibility of all employees. It is encouraged by a flat organizational chart and a culture that encourages open discussion of potential risks, with local managing directors leading by example.

H&R AG uses the "COSO" (Committee of Sponsoring Organizations of the Treadway Commission) model to assess risks; this method is one of the standards for internal controls recognized by the American Securities and Exchange Commis-

sion (SEC). The risk manager (generally the relevant operations manager) conducts on-site risk assessments on a quarterly basis by means of a questionnaire, an inventory list, a data collection form and a current calculation document. Risks are classified according to certain criteria. They are then measured using an approach in which the nominal extent of a potential risk is multiplied by the probability of its occurrence. All risks measured for an individual company are entered in the "risk inventory" and reported quarterly to the Risk Control department of the parent company, H&R AG. The Risk Control department helps the risk managers to establish early warning indicators that make it possible to react quickly if a risk becomes more acute. The early warning indicators are checked regularly to ensure that they are appropriate and up to date. Where possible and economically feasible, measures to reduce or avoid risks are also defined.

Every quarter, the Risk Control department sends the Executive Board the consolidated risk inventory, including a detailed breakdown of the Value-at-Risk (VaR), which serves as the basis for controlling overall risk. If new risks arise at short notice or a loss event occurs, the Executive Board is notified directly, independently of normal communication channels.

In addition, a monthly performance report is prepared for all the main individual companies and the Group. This report compares revenue and earnings figures with the relevant target figures. The Risk Control department analyzes any variances between target and actual figures. These analyses enable the Executive Board to identify undesirable trends at an early stage so that the necessary countermeasures can be implemented immediately.

The regular divisional meetings attended by local managing directors and the Executive Board are another tool used for early risk-detection. The interface thus created between the operating and administrative levels ensures that operational risks are captured by and reflected in the accounting process (e.g., in the form of provisions) and communicated internally.



**Risk report**

Description of the main features of the internal control and risk management system with regard to the Group accounting process (Art. 289 Para. 5 and Art. 315 Para. 2 No. 5 HGB)

At Supervisory Board meetings, changes in the risk inventory and the risk strategy are dealt with at least once a year as part of the risk management reporting process. If the risk situation changes significantly, the Supervisory Board is also informed promptly between meetings by the Executive Board.

The functionality and effectiveness of the risk early-warning system are reviewed not only by the Executive Board, but also on a regular basis as part of the audit of the financial statements. The results of these audits are taken into consideration in the ongoing refinement of our risk management system.

#### G. 14 RISK MANAGEMENT CONTROL SYSTEM

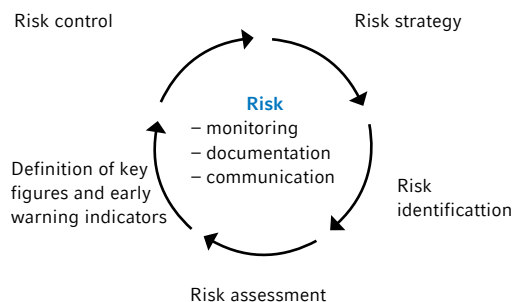

#### Description of the main features of the internal control and risk management system with regard to the Group accounting process (Article 289, paragraph 5 and Article 315, paragraph 2, no. 5 of the German Commercial Code/HGB)

H&R AG's accounting guidelines specify uniform accounting and valuation principles for the companies included in the consolidated financial statements in accordance with International Financial Reporting Standards (IFRS). New accounting regulations are reviewed immediately to determine whether they affect companies in the H&R Group and if necessary are incorporated into our accounting guidelines. The local managing directors are responsible for the application of existing regulations at the level of the individual companies. Consolidated financial statements are prepared and drawn up by Group Accounting at H&R AG. The employees of this department also serve as contact persons to answer questions on accounting matters from the subsidiaries.

To minimize the risk of incorrect accounting even in complex circumstances, H&R AG employees involved in the accounting process undergo continuous and extensive training. The relevant departments have the appropriate manpower, both in terms of numbers and competence. Advice on specific accounting matters is also obtained from external experts as necessary. The internal control system at the H&R Group consists of principles, processes and measures which ensure that the accounting is effective, economical and correct and complies with the relevant legal requirements.

The H&R Group's internal control system consists of a management system and a monitoring system.

Important aspects of the measures that have been integrated into our processes include both manual controls, such as the dual-review principle, and automated IT controls.

The Audit Committee of H&R AG's Supervisory Board is integrated into the H&R Group's internal monitoring system through its audit activities,



which are independent of operating processes. In accordance with Article 107, paragraph 3 of the German Stock Corporation Act (AktG), this body primarily focuses on monitoring the accounting process, the audit of the financial statements and the effectiveness of the internal control and risk management system.

Extensive access regulations for the relevant IT systems and a strict dual-review policy in the Accounting Departments – both at the individual companies and at the Group level – ensure that the accounting processes are thorough, precise and secure.

The subsidiaries are obliged to report their figures to Group Finance every month in a standardized format in accordance with IFRS accounting rules. This enables variances between target and actual figures to be identified at an early stage and gives us the opportunity to determine the reasons behind the variances and to take any necessary countermeasures.

### The risk management system relating to derivative financial instruments

H&R AG has very strict rules governing the use of derivative financial instruments. We only use standard market instruments from selected banks with good ratings. As a rule, the transactions are carried out by the Group Treasury department after approval by the Executive Board and are then monitored on an ongoing basis. They are used to hedge underlying transactions that either exist already or are highly likely to take place in the future (anticipatory hedging). Derivative financial instruments are not used for speculative purposes. The contracts currently in place serve mainly to hedge interest-rate and currency risks.

## Opportunities management

At the H&R Group, the systematic management of opportunities is closely linked to the management of risks. We define opportunities as developments which could have a positive effect on our results of operations, financial position and net assets. Operating opportunities are identified and exploited in the various segments, as it is within the segments themselves that the greatest product and market knowledge is to be found. Managing strategic opportunities – such as acquisitions, joint ventures or major investments – is the responsibility of the Group's Executive Board. We use a variety of methods to make the best use of both operating and strategic opportunities. As well as carefully analyzing our sales and procurement markets, we also carry out scenario planning and try to identify future market trends by engaging in targeted discussions with customers. In the Chemical-Pharmaceutical segments, there is an active exchange of ideas on these issues between the production sites, our Research & Development department and our sales and distribution partner Hansen & Rosenthal, which uses its close customer contacts to identify current and future customer needs and to provide ideas for new products.

## Individual risks

Throughout the Group, we have standardized the classification of all our relevant risks. A risk is classified as low, medium or high based on the parameters "Probability of Occurrence" and "Potential Financial Impact". The resulting risk classification matrix is shown in the following table:

**Risk report**  
Individual risks

**T.31 POTENTIAL FINANCIAL IMPACT\***

	Likelihood of occurrence**		
	Unlikely	Possible	Likely
Existential threat	●	●	●
Significant	●	●	●
Moderate	●	●	●

\*Moderate: Some negative effects on e.g. business activity, financial and earnings position as well as cash flows for as long as EBITDA is less than €30.0 million in 2014.

Significant: Substantial negative effects on e.g. business activity, financial and earnings position as well as cash flows for as long as EBITDA is less than €30.0 million in the next two years.

Existential threat: Considerable negative effects on e.g. business activity, financial and earnings position as well as cash flows owing to which the continued existence of the enterprise would be jeopardized, e.g. with an EBITDA permanently below €30.0 million.

\*\* 1-33%: Unlikely; 34-66%: Possible; 67-99%: Likely

● Low risk

● Medium risk

● High risk

Depending on the degree of a potential financial effect and the estimated likelihood of occurrence,

risks are generally classified as being “high”, “medium” or “low”.

**T.32 CORPORATE RISKS**

	Likelihood of occurrence	Possible financial impact	Risk situation compared to previous year
<b>Macroeconomic and industry risks</b>			
Fluctuations in demand and margins	possible	significant	unchanged
Risks in regard to the supply of raw materials	unlikely	significant	unchanged
Risks from the development of substitute products and general competition	likely	moderate	unchanged
Changes in the tax and legal environment	possible	moderate	unchanged
<b>Operating and corporate strategy risks</b>			
Production risks	unlikely	significant	unchanged
Investment risks	unlikely	significant	lower
Risks associated with sales/distribution relationship with Hansen & Rosenthal Group	unlikely	significant	unchanged
Product liability risks	unlikely	moderate	unchanged
Information technology risks	unlikely	significant	unchanged
Personnel risks	unlikely	moderate	unchanged
<b>Financial risks</b>			
Liquidity risks	unlikely	significant	unchanged
Risks from the breach of covenants	possible	significant	lower
Risks from future refinancing requirements	possible	significant	higher
Exchange rate risks	possible	moderate	unchanged
Interest rate risks	possible	moderate	higher
Risks from defaulting customers and banks	unlikely	moderate	unchanged
<b>Other risks</b>			
Risks relating to the remediation costs for land in Haltern am See	possible	moderate	unchanged
Claims for damages in connection with the cartel fine	unlikely	moderate	lower

### Macroeconomic and industry risks

**DEMAND AND MARGIN FLUCTUATIONS (RISK CLASS: HIGH).** External influences can cause demand for our chemical-pharmaceutical specialty products and high-precision plastic parts to decline. These external factors may include periods of economic weakness, temporary price dumping by existing competitors or the emergence of new suppliers in relevant markets.

We continue to generate the majority of our sales revenues in Europe. Economic developments in this region therefore have an important influence on our sales and earnings trend.

In the Plastics Division, there is a risk of an excessive dependency on direct suppliers to the automotive industry, for example as automobile manufacturers' declining sales also affect H&R AG's business indirectly. Accordingly, we make every effort to diversify into new customer areas. Expanding our activities beyond Europe also furthers our global presence and makes us less dependent on developments in the domestic economy.

Closely correlated with the risk of weak demand is the risk of low product margins. As the fixed costs of the complex plants in the chemical industry are relatively high, lower margins are often tolerated at times of weaker demand in order to maintain capacity-utilization rates. We counter this risk with the targeted expansion of the percentage of our business that generates crude-oil-based specialty products that are less price sensitive.

As a rule, fluctuating raw-material prices and low prices for base oils also result in product-margin volatility. Base oil is a by-product of our joint production process and is used to make motor oils, among other things. If commodity prices are high and base-oil prices are simultaneously low, this will affect margins accordingly. Even with moderate raw-material prices, the effects can have a significant impact. The conversion of the Salzbergen Refinery to contract production in 2013 has significantly reduced the risk of these effects over the past 18 months.

At the same time, for financial year 2014 as a whole, H&R AG benefited from a favorable trend:

the difference between the purchase price of raw materials and the selling price of base oil. Although the company was able to take advantage of the opportunities presented by commodity- and product-price volatility in the form of better margins, the sharp fall in prices of raw materials at the end of November 2014 was a negative factor when valuing the Hamburg refinery's inventories. Consequently, the company had to recognize windfall losses. Although in terms of opportunities there is also a potential for windfall profits, the company continues to classify the risk as "High" due to the likelihood of occurrence and significant impact.

The high degree of competition in the plastics industry means that for many product groups, there is a risk of having to accept lower margins in order to safeguard or expand market share. We are therefore pressing ahead with production in product segments with a more attractive market environment, such as medical technology. In some cases, the risk of increases in raw-material prices can partly be passed on to our customers through escalation clauses. Because of the lower business volume, the financial impact of a risk occurring is also lower.

**RISKS RELATED TO RAW MATERIALS PROCUREMENT (RISK CLASS: MEDIUM).** At our specialty refineries in Hamburg and Salzbergen, the main raw material is a residue left over when fuels are produced from crude oil. To minimize the risk of supply shortages, we purchase this so-called long residue from different sources. To this end, we sign annual volume agreements with several well-known oil companies from different areas of the world. We purchase a greater percentage on the spot market in order to diversify our sources even further.

In the International Chemical-Pharmaceutical Division and the Plastics Division, our strategy for avoiding raw-material supply shortages is also based on having several suppliers for important raw materials.

**RISKS FROM THE DEVELOPMENT OF SUBSTITUTE PRODUCTS AND GENERAL COMPETITION (RISK CLASS: MEDIUM).** One risk applicable to both divisions is the development of substitutes or al-

ternative production methods for our products. Furthermore, for the Chemical-Pharmaceutical segments, there is a risk that customers may develop manufacturing processes which rely to a lesser extent or not at all on crude-oil-based specialty products as feedstock. We address these risks through intensive research and development activities in all the Group's operating divisions. This approach makes us the leading innovator in some product groups. The high degree of diversification in our product portfolio also reduces the effects individual substitutes would have on Group earnings. Moreover, there are a number of limitations in terms of quality, performance, compatibility with established manufacturing processes, availability, environmental impact and price for potential chemical and renewable raw-material substitutes.

In addition to substitution risk, there is also the possibility, over the lifecycle of a given product, that competitors will develop and bring to market products of their own which are identical to our specialty products. This would expose us to greater competitive pressure.

Due to the many unknowns, the risk arising from market or competitive trends cannot be quantified.

 CHANGES IN THE TAX AND LEGAL ENVIRONMENT (RISK CLASS: MEDIUM). As a refinery operator, we are subject to strict regulations governing emissions of CO<sub>2</sub>, particulates and noise, as well as water pollution. A potential tightening of these regulations entails the risk of financial costs resulting from the need to make new investments to modernize our plants. We limit these risks by anticipating the introduction of stricter rules, by going beyond the requirements of many current environmental protection standards and by trying to use these aspects for marketing purposes as well. This means that most investments in environmental protection simultaneously increase our profitability. For example, modern tank insulation at our refineries not only reduces our CO<sub>2</sub> emissions, but also cuts our energy costs significantly.

Despite extensive investments to improve energy efficiency, however, operating our refineries continues to be energy intensive. The tendency towards reducing energy tax subsidies for the manufacturing industry in Germany therefore creates a further risk of competitive disadvantages.

#### Operating and corporate strategy risks

TECHNICAL PRODUCTION RISKS (RISK CLASS: MEDIUM). The subsidiaries of H&R AG produce crude-oil-based specialty products and high-precision plastic parts. Operating the plants that produce such products entails both operating risks and accident risks. Technical disruptions, flooding, fires or explosions can cause harm to people or the environment and result in production downtime.

We counter these risks with a comprehensive safety strategy: extensive control and safety measures, coordinated by our IT-based measuring stations, enable us to identify many production risks at an early stage and to adopt suitable countermeasures. We also invest regularly in environmental protection and safety measures at our refineries. The certification of our production sites in accordance with strict ISO standards contributes significantly to ensuring that production processes are safe. If an accident occurs despite these precautions, the financial losses are largely covered by insurance, provided that the risk is insurable and such coverage makes sense from a financial and economic standpoint. 

RISKS ASSOCIATED WITH THE SALES/DISTRIBUTION RELATIONSHIP WITH THE HANSEN & ROSENTHAL GROUP (RISK CLASS: HIGH). Sales of the ChemPharm Refining segment's products are handled almost exclusively by companies belonging to the Hansen & Rosenthal Group, which acts as sales/distribution partner under long-term contracts, reflecting many years of business ties; the Group is also a significant customer of H&R AG.

The company and the sales/distribution partner are currently negotiating a revision of the sales/

distribution agreement. If this agreement is not concluded and the Hansen & Rosenthal Group is no longer available as sales/distribution partner, this would have a considerable negative impact on H&R AG's net assets, results of operations and financial position. Among other things, the company would have to develop its own sales and distribution capacity for the ChemPharm Refining segment at short notice. Even if it succeeded in doing so, it would still face the risk of either not being able to establish direct customer relationships at all or not being able to do so over the long term.

While H&R AG estimates the impact of such a risk, if it should occur, as "High", at the same time it rates the probability that such a risk will materialize as "Unlikely". H&R AG is part of the Hansen & Rosenthal Group, the main shareholder and Managing Director of which is also the company's majority shareholder. The interdependencies are not one-sided only; to the contrary, the company is the current sales/distribution partner's biggest supplier. Consequently, the successful conclusion of a new sales/distribution agreement is in both parties' interest.

The contract production at the Salzbergen site is also carried out exclusively for the Hansen & Rosenthal Group. In principle, the loss of this contractual relationship would have an impact on H&R AG; however, this is considered very unlikely, because of the fact that the agreement has just been renewed.

**INVESTMENT RISKS (RISK CLASS: MEDIUM).** In the years ahead, we intend to keep investing in measures to maintain the value of our existing production sites. In principle, investment projects may entail cost overruns and delays in construction. To mitigate these risks, we deploy project teams with in-depth knowledge of our plants who will therefore professionally coordinate and strictly monitor such value-maintenance measures. In addition, these measures always take place in plants whose technology has already been tried and tested in practice and in which the financial costs can be estimated with above-average certainty.

For the current financial year, we are not planning any new business acquisitions, whether in the area of chemical-pharmaceutical raw materials or in the production of high-precision plastic parts. At present, there are therefore no acquisition-related risks that might arise from the integration of employees, technologies and processes.

**PRODUCT-LIABILITY RISKS (RISK CLASS: LOW).** Our crude-oil-based specialty products and plastic parts are incorporated directly into our customers' products. Incorrect specifications for our products may result in damages to our customers and give rise to warranty claims. For this reason, all the products in both our Chemical-Pharmaceutical Division and our Plastics Division are subject to intensive quality controls. If we are faced with liability claims despite this, we are largely covered by insurance.

**IT RISKS (RISK CLASS: MEDIUM).** The increasingly networked nature of our complex information-technology systems carries risks. Vital data can be falsified or deleted by unauthorized access from outside, operating errors or faulty programming.

To address this risk, we have an external service provider make regular back-ups of our current data. To protect ourselves against malicious hackers, we have complex firewalls in place and virus scanners that update themselves continually. An extensive access-authorization system is also used to protect sensitive data. We have taken precautions against a complete breakdown of our data center by establishing a fallback data center, which can take over most important IT functions at short notice. We also counter information-technology risks by means of ongoing investments in hardware and software and by continuously improving our system expertise. Our IT department is suitably equipped for a company the size of the H&R Group and will continue to make every effort to optimize all our resources.

**HUMAN-RESOURCES RISKS (RISK CLASS: LOW).** Qualified and committed employees play an important role in our success. In the chemical industry, there is a great deal of competition for highly

qualified staff to operate plants and refine production processes. We limit the associated risk of turnover through a number of personnel-policy measures: a pleasant working atmosphere, targeted development opportunities for junior staff and practical training and continuing education for professionals all help to create an attractive working environment.

Our Research & Development department has a wide range of cooperation arrangements with various universities which help establish contact with high-potential candidates at an early stage. A flat organizational chart, good development opportunities and a performance-related remuneration system also make us an attractive employer for experienced professionals.

We also boost our employees' motivation with attractive performance-related pay schemes, a company platform for making suggestions for improvement and activities throughout the Group to encourage healthy living.

#### Financial risks

**LIQUIDITY RISKS (RISK CLASS: MEDIUM).** Prices for the raw materials used in our Chemical-Pharmaceutical segments are closely correlated with the price of crude oil. The prices for our raw materials are therefore subject to frequent fluctuations. The prices for our finished products are similarly volatile. As a result, until the Salzbergen site was converted to the contract-manufacturing model, the balance sheet items "inventories" and "trade accounts receivable" used to increase accordingly when the price of crude oil went up.

In order to cover the net working capital required for our production activities (the sum of inventories and trade accounts receivable less trade accounts payable), a large part of the line of credit under our syndicated loan totaling up to €72.5 million has been earmarked as a risk cushion. In business year 2014, we drew down an average of €38.4 million per quarter of the syndicated loan in the form of guarantees and letters of credit. Our Group Treasury department monitors our liquidity status on a daily basis to avoid any cashflow difficulties.

The banks in the lending syndicate attach financial covenants to the credit lines relating to our equity and the ratio of our net debt to operating earnings (EBITDA). If any of these covenants are breached, the banks are entitled to call in the loan.

**FINANCIAL COVENANT BREACH RISK (RISK CLASS: HIGH).** Compliance with the financial covenants will also be a crucial part of the financing agreements in 2015. If these covenants were to be breached again, this could jeopardize the continued existence of the financing arrangements and therefore the Group's financial and economic situation. With the set of measures implemented in 2013 to reduce debt and to improve earnings, the company has made a sustainable contribution to de-risking and de-leveraging. The amount of net debt allowed and the amount of accounts receivable sales allowed were revised in financial year 2014. Both measures are attributable exclusively to the contribution by China; we were in full compliance with the financing terms in 2014. Because of the possibility of occurrence and the potentially significant financial consequences, this remains – from an objective standpoint – a "High-risk" issue. Overall, though, we believe the risk situation has eased, not least because of our continued compliance with the covenants during the past two financial years.

**RISKS OF FUTURE NEED TO REFINANCE (RISK CLASS: HIGH).** H&R AG has entered into various loan agreements and borrower's note loans with banks, some of which expire in 2016. Payments due on the 5-year tranche of the borrower's note loan total €63.0 million. The syndicated loan amounting to €72.5 million will have to be renegotiated in 2016 as well. There is no guarantee per se that it will be possible to refinance in the future under the same or more favorable terms and conditions – if at all.

In general, given the ECB's current low-interest policy, banks' involvement in the financial instruments used by H&R AG must nevertheless be seen as an attractive investment. Because the lending banks' risk even in the event the company's financial and economic situation should





For further  
information  
see page 105

deteriorate would be manageable (raw material and product inventories that can be sold at short notice), we assume that we will succeed in obtaining follow-up financing. However, if we ultimately do not manage to refinance, the company would have to use a higher percentage of its cash and cash equivalents to repay these amounts. This could have a significant impact on business activities, as well as on the company's net assets, financial position and results of operations.

**RISKS FROM DEFAULTING CUSTOMERS AND BANKS (RISK CLASS: LOW).** Our risks from delays in payment and/or defaults on the part of our customers are limited by our broadly diversified customer base and the low level of dependence on individual debtors. Strict receivables management by our sales/distribution partner, Hansen & Rosenthal, reduces these risks even further. Trade-credit insurance has also been taken out for a number of major customers.

The default risk for banks with which we have arranged credit lines, entered into hedging transactions or invested funds has increased since the onset of the financial crisis. We counter this risk by only entering into financial transactions with top-rated banks and by spreading larger transactions among several banks.

**EXCHANGE-RATE RISKS (RISK CLASS: MEDIUM).** As an international Group, we are exposed to various exchange-rate risks, which for cost-benefit reasons we generally do not hedge. The depreciation of a foreign subsidiary's local currency can diminish the cash flow generated there in terms of the Group currency, the euro. Furthermore, revenue from the sale of products from within the Eurozone to a country outside the Eurozone will fall if the foreign currency in question depreciates against the euro.

Some of the most important foreign currencies for us are the U.S. dollar, the Australian dollar, the pound sterling, the Thai baht, the Malaysian ringgit and the South African rand. For a sensitivity analysis of exchange-rate fluctuations between

the U.S. dollar and the euro, our Group currency, please refer to the [Notes](#). Nonetheless, despite the strong growth in our international business, around 80% of our sales are still invoiced in euros. Overall, we weigh the costs for hedging all foreign currency risks against the financial effects of a potential loss event. So long as the probability of occurrence is no more than 50%, we will dispense with the corresponding hedge transactions.

The U.S. dollar/euro exchange rate also affects our raw-material costs, as we purchase our main raw materials – the crude-oil derivatives long residue and vacuum gas oil – in U.S. dollars. An increase in the value of the U.S. dollar against the euro therefore increases our raw-material expenses.

**INTEREST-RATE RISKS (RISK CLASS: MEDIUM).** In order to secure long-term conditions and greater diversity in our Group financing, in November 2011 we took out a borrower's note loan for a total of €150.0 million (reduced to €116.0 million in March 2014) and a new syndicated loan for up to an additional €150.0 million (reduced to €72.5 million in February 2014). The interest payable on one €80.0 million tranche of the borrower's note depends on the general trend in money-market rates. We have arranged interest-rate hedges of €80.0 million to cover this portion of the borrower's note loan. The interest-rate risk is therefore limited to drawdowns on the credit lines granted under our syndicated loan that exceed this amount.

There are also company retirement liabilities in the form of pension commitments. The actual amount of these commitments is based, on the one hand, on an actuarial forecast and, on the other hand, is heavily dependent on conditions in the capital markets, in particular the interest rate. As of 31 December 2014, the current low-interest policy caused pension liabilities to increase by around €10.0 million and resulted in a corresponding charge against H&R AG's equity. If this trend persists, it may result in further increases

**Risk report**

General statement on the risk situation | Opportunities

of the pension liabilities and therefore in corresponding charges against earnings.

**Other risks**

**RISKS RELATING TO THE REMEDIATION COSTS FOR THE LAND IN HALTERN AM SEE (RISK CLASS: MEDIUM).** The site of our factory in Haltern am See was used by the German Empire and Third Reich, respectively, during the two World Wars for the production of armaments, contaminating the ground in a number of areas with compounds typical of explosives. The compounds have also been detected in the groundwater of the surrounding area. For this reason, the Recklinghausen district council issued an order in early 2010 prohibiting the extraction of ground water from domestic wells in the district of Haltern-Lembrake. Even though we did not cause the contamination, there is a risk of financial costs from further investigations or remediation measures. However, the provision of €1.1 million for this contingency means that the balance sheet adequately reflects these risks from today's perspective.

**CLAIMS FOR DAMAGES IN CONNECTION WITH THE CARTEL FINE (RISK CLASS: LOW).** From 2005 onwards, the European competition authority carried out investigations into possible collusive anti-competitive conduct in the paraffin market between 1994 and 2005. In a ruling dated 1 October 2008, the Commission found various European wax manufacturers guilty of breaches of anti-trust law. Companies in the Hansen & Rosenthal Group and H&R AG were fined a total of €36.0 million. H&R ChemPharm GmbH, which is part of the H&R Group, is jointly liable for €22.0 million of this amount. After a detailed examination of the grounds for the ruling, the companies lodged an appeal in December 2008, both against the Commission's ruling and the amount of the fine. The Court of Justice of the European Union in Luxembourg issued a first-instance ruling against our legal position in December 2014.

Notwithstanding the appeal, the sum of €22 million was paid in early 2009 within the stipulated time period. The Executive Board does not expect any further customer damage claims to be filed.

**General statement on the risk situation****Assessment of the risk situation by company management**

Our overall risk situation is assessed with the help of our risk management system and the established planning and control systems. When all material individual risks are reviewed in aggregate, potential opportunities are not taken into account as offsets. We therefore believe that, based on the currently available information, there are no risks that could jeopardize the continued existence of the H&R Group as a going concern.

**Company rating**

The creditworthiness of H&R AG has not been evaluated by an independent rating agency. Our banking partners review the credit standing of H&R AG on an ongoing basis.

**Opportunities**

H&R AG operates in an environment that may constantly provide new opportunities, as our company, our customers and our markets are continually undergoing further development. Only if we recognize and take advantage of such opportunities, while simultaneously keeping the related risks in mind, will we be able to successfully exploit the factor that is essential for a sustainable improvement in our company's earnings. As part of our opportunity management, we perform analyses of the market and our competitors that are as precise as possible. We develop scenarios for successful market entry, question the focus of our product portfolio, evaluate the cost drivers as well as the relevant success factors and from this information identify specific market opportunities that are then coordinated by the Executive Board in close collaboration with the local operations managers. According to the degree of potential financial impact and the likelihood they will materialize, we classify our opportunities in the same way we do our risk classes.



#### Opportunities arising from macroeconomic trends (Opportunity class: Medium)

The Chemical-Pharmaceutical segments could benefit from the gradual withdrawal of the big oil companies from the crude-oil-based specialty-products business. In Western Europe alone, the Group 1 refineries' generating capacity could drop by around one-fifth over the next 18 to 24 months. By contrast, H&R's refineries can continue to provide these products and the fact that a higher share of their capacity is devoted to specialty products than to lubricants may mean that they would have another advantage over the remaining Group 1 refineries. If the demand for crude-oil-based specialty products increases at the same time, our revenues and earnings could exceed current expectations.

Over the last few years, we have laid the foundation for profitable business in a number of emerging markets in East Asia. For 2015, economic analysts currently expect a level of momentum that will result in 5% growth over the coming year (2014: 4.2%; Source: Kiel Institute for the World Economy/iFW). If these economies develop in line with the forecasts, this could have a positive impact on our company, our results of operations and our cash flows and could lead to better overall performance than expected.

In recent years, we have concentrated on developing environmentally friendly products that satisfy the highest quality standards. Stricter environmental regulations or mandatory disclosures about product characteristics in our customer industries could also create additional incentives to use our crude oil-based specialty products and plastic parts.

For the Plastics Division, demographic developments will create attractive growth opportunities, especially in the field of medical technology. Further opportunities will be generated by the trend in the automotive industry towards replacing heavy metal parts with lighter plastic components to reduce vehicle weight.

#### Strategic opportunities for the company (Opportunity class: High)

In the Chemical-Pharmaceutical segments, we see considerable opportunities in extending the value chain even further and increasing production efficiency with innovative manufacturing processes. In addition, our Research & Development department is working on innovative products that, once they are ready for market, could create significant added value for our customers. If we make faster progress in our research and development, this could be accompanied by the market launch of newer, improved products. This could have a positive effect on our revenues and our earnings and enable H&R AG to exceed current expectations.

Internationally, we actively monitor market trends and align regional opportunities with our international expansion strategy. To do this, we can rely on our existing network of subsidiaries as important strategic bridgeheads that will enable us to quickly penetrate emerging markets in a carefully targeted manner. An example here is the trend in China: important players in the tire industry have relocated their manufacturing operations to Asia, where they demand the same quality they previously required at their European sites. China, which is such an important sales market for the automotive industry, will follow this trend and will also ensure a high level of demand for high-quality tires that pose no risk to health. H&R AG possesses the know-how to manufacture such tire components and, thanks to the takeover of the Hansen & Rosenthal Group's Chinese businesses, it now also has the necessary local production capacity.

In the Chemical-Pharmaceutical Division, we are already taking advantage of joint-production agreements with local partners who enable us to develop new markets in a stable and successful manner. Expanding collaboration beyond the production area will help us to exploit synergies with our sales/distribution partners. Increasing the market penetration of our products could also have a positive effect on our business and lead to an improved earnings situation.

**Risk report**

Overall statement on the expected development of the Group

Basically, we should note that, thanks to our high degree of diversification both at the product and customer levels, overall demand for our products is relatively stable. Opportunities also arise from the fact that many of our specialty products are being used simultaneously in several of our numerous customer industries. For example, our high-quality paraffins are used in the candle, building-material and food industries – sectors with very different economic cycles.

**Economic performance opportunities (Opportunity class: Medium)**

The refinery-operation business is very energy intensive. By investing in CO<sub>2</sub> reduction and lower energy consumption, H&R AG has already met important climate goals in the past, with the concomitant reductions in energy costs. At the same time, we availed ourselves of the legal opportunities for an exemption from the surcharge imposed by the Renewable Energy Act (Erneuerbare-Energien-Gesetz/EEG) in order to further boost performance.

In the past, our Chemical-Pharmaceutical segments have seen periods of increased profitability in which we temporarily earned what are known as windfall profits. These arise in market situations in which raw-material prices decline and product prices remain constant. This opportunity continues to exist, albeit to a lesser extent after the conversion of the Salzbergen refinery to the contract-manufacturing model.

We can also benefit – in the form of higher margins – when the supply of our products becomes scarce, such as during shutdowns, closings or capacity reductions at our competitors' refineries. For the Western European Group 1 refineries alone, industry experts expect production capacity to drop by around one-fifth from this year's level over the next two years. Accordingly, not only will the number of suppliers for many of our products decline; because our refineries focus on high-value specialty products while lubricants account for only a small percentage, these refineries should have a competitive edge over competitors that are more heavily weighted towards base oil.

More intensive, targeted marketing of our by-products will also create opportunities. For example, we are currently producing bitumen, which is primarily used in road building, as a by-product at our propane-deasphalting plant. However, by building new process-engineering plants, so-called cokers, bitumen can also be used as a feedstock for producing diesel and low-sulfur heating oil. Currently, two such cokers have been built in Europe; others are expected to follow in the USA and in Saudi Arabia. The more bitumen is used as a feedstock, the higher the demand may be for available high-quality bitumen for infrastructure projects.

In the Plastics Division, new large-scale orders from the automotive supply or medical technology sectors could lift revenue and earnings above our expectations.

**Overall statement on the expected development of the Group**

The decline in sales revenues in 2014 once again showed that this parameter is not very meaningful: influenced only by lower raw-material costs, the lower sales figure was contradicted by strong demand and satisfactory sales volumes. Our revenues will likewise follow the trend in commodity prices in financial year 2015. Despite this, we expect production and demand to remain at the constant, good level we have seen in recent years.

In 2014, earnings were once again overshadowed by market developments. The positive effects of low raw-material costs and acceptable base-oil prices were offset by valuation effects ("windfall losses") on our raw-material inventories, which once again turned quite negative just before the end of the year. We consider the negative impact of this valuation to be a one-time effect which, first, is almost meaningless as far as our operating performance is concerned and, second, should be cancelled out (and again be positive) as soon as raw-material prices increase.

Moreover, 2014 again confirmed the importance, as well as the clout, of the company's main drivers of earnings. In 2015 we will continue to take advantage of the value-creation and efficiency factors in order to improve our financial ratios in a sustainable manner. Our improved raw-material and energy management system has enabled us to build a stable foundation for this upward trend. China has proved to be an important engine to propel us toward our goal of expanding further internationally; in 2015, it will for the first time deliver a full year of sales and earnings contributions to our Group.

At the same time, we expect external factors, the macroeconomic environment and future market trends to positively affect our business. The experience of the past two years, however, has taught us to be even more conservative than previously. For financial year 2015, we are projecting operating income (EBITDA) of between €45.0 million and €65.0 million, with sales on a par with the previous year.

**CONSOLIDATED FINANCIAL STATEMENTS**

98	Consolidated balance sheet
100	Consolidated income statement
101	Consolidated statement of comprehensive income
102	Consolidated statement of changes in shareholders' equity
104	Consolidated cash flow statement
105	Notes
105	(1) General information
106	(2) Effects of the new accounting standards
107	(3) General balance sheet preparation and evaluation methods
116	(4) Discretionary decisions and estimates
117	(5) Scope of consolidation and holdings
120	Notes to the consolidated balance sheet
135	Notes to the consolidated income statement
139	Additional notes
156	Attestation by the legal representatives
157	Auditor's report



## Consolidated balance sheet

## Consolidated balance sheet of H&R AG

as of 31 December 2014

**ASSETS**

€ THOUSAND	Notes	31/12/2014	31/12/2013
<b>Current assets</b>			
Cash and cash equivalents	(6)	101,558	109,624
Trade accounts receivables	(7)	105,598	109,725
Income tax claims	(33)	1,701	414
Inventories	(8)	134,202	116,205
Other financial assets	(9)	2,176	1,797
Other assets	(10)	8,630	3,681
<b>Current assets</b>		<b>353,865</b>	<b>341,446</b>
<b>Non-current assets</b>			
Property, plant and equipment	(11)	255,280	197,906
Goodwill	(12)	39,908	32,132
Other intangible assets	(12)	32,885	3,421
Shares in at-equity valued holdings	(13)	763	923
Other financial assets	(9)	5,382	4,100
Other assets	(10)	1,465	1,531
Deferred tax assets	(33)	17,069	13,197
<b>Non-current assets</b>		<b>352,752</b>	<b>253,210</b>
<b>Total assets</b>		<b>706,617</b>	<b>594,656</b>

**EQUITY AND LIABILITIES**

€ THOUSAND	Notes	31/12/2014	31/12/2013
<b>Current liabilities</b>			
Liabilities to banks	(14)	52,018	13,312
Trade accounts payables	(15)	112,415	121,743
Income tax liabilities	(33)	2,230	3,313
Other provisions	(16)	9,298	7,850
Other financial liabilities	(17)	12,813	4,628
Other liabilities	(18)	9,948	11,901
<b>Current liabilities</b>		<b>198,722</b>	<b>162,747</b>
<b>Non-current liabilities</b>			
Liabilities to banks	(14)	156,051	168,229
Pension provisions	(19)	82,566	63,566
Other provisions	(16)	4,270	4,548
Other financial liabilities	(17)	4,712	5,533
Other liabilities	(18)	79	101
Deferred tax liabilities	(33)	11,314	770
<b>Non-current liabilities</b>		<b>258,992</b>	<b>242,747</b>
<b>Equity</b>			
Subscribed capital	(20)	91,573	76,625
Capital reserve	(21)	43,329	18,599
Revaluation surplus	(22)	-2,532	-3,616
Retained earnings	(23)	73,773	102,833
Foreign currency translation adjustments		2,958	-5,200
<b>Equity of shareholders of H&amp;R AG</b>		<b>209,101</b>	<b>189,241</b>
Non-controlling interests	(24)	39,802	-79
<b>Total equity</b>		<b>248,903</b>	<b>189,162</b>
<b>Total equity and liabilities</b>		<b>706,617</b>	<b>594,656</b>

## Consolidated income statement

## Consolidated income statement of H&amp;R AG

1 January 2014 to 31 December 2014

€ THOUSAND	Notes	2014	2013
Sales	(26)	1,058,622	1,214,396
Changes in inventories of finished goods and work in progress	(8)	387	-56,514
Other operating income	(27)	18,742	22,254
Cost of material	(28)	-881,350	-981,283
a) Expenditure on raw materials, supplies and merchandise		-843,402	-939,563
b) Purchased services		-37,948	-41,720
Personnel expenses	(29)	-72,707	-71,386
a) Wages and salaries		-61,680	-60,738
b) Social security payments and expenses for pensions and for support		-11,027	-10,648
Depreciation, impairments and amortisation		-25,639	-36,734
Other operating expenses	(30)	-92,350	-95,213
<b>Income from operations</b>		<b>5,705</b>	<b>-4,480</b>
Net interest result	(31)	-13,811	-16,163
a) Interest income		512	309
b) Interest expenses		-14,323	-16,472
Result of at-equity reported shareholdings	(13)	124	369
Other financial result	(32)	151	3,425
<b>Earnings before taxes (EBT)</b>		<b>-7,831</b>	<b>-16,849</b>
Income taxes	(33)	-7,777	2,812
<b>Income after taxes</b>		<b>-15,608</b>	<b>-14,037</b>
of which attributable to non-controlling interests		-206	-8
<b>of which attributable to H&amp;R AG shareholders</b>		<b>-15,402</b>	<b>-14,029</b>
Earnings per share (undiluted), €	(34)	-0.49	-0.47
Earnings per share (diluted), €	(34)	-0.49	-0.47



# Consolidated statement of comprehensive income of H&R AG

1 January 2014 to 31 December 2014

€ THOUSAND	Notes	2014	2013
<b>Income after taxes</b>		<b>-15,608</b>	<b>-14,037</b>
of which attributable to non-controlling interests		-206	-8
of which attributable to shareholders of H&R AG		-15,402	-14,029
<b>Positions that will not be reclassified into profit or loss</b>			
Remeasurement of defined benefit pension plans		-18,732	-1,249
Deferred income taxes		5,074	387
<b>Change in the amount included in equity (remeasurement of defined benefit pension plans)</b>		<b>-13,658</b>	<b>-862</b>
<b>Positions that will subsequently possibly be reclassified into profit or loss</b>			
Changes in the fair value of derivatives held for hedging purposes		-	37
Amount reclassified into profit and loss		950	966
Deferred income taxes		-	-10
<b>Changes recognized outside profit and loss (cash flow hedges)</b>	(37)	<b>950</b>	<b>993</b>
Changes in the fair value of financial assets available for sale		82	-10
Deferred income taxes		52	2
<b>Changes recognized outside profit and loss (financial assets available for sale)</b>	(37)	<b>134</b>	<b>-8</b>
<b>Changes of the balancing item due to currency translation</b>		<b>9,010</b>	<b>-10,181</b>
<b>Total other comprehensive income</b>		<b>-3,564</b>	<b>-10,058</b>
of which attributable to non-controlling interests		852	3
of which attributable to shareholders of H&R AG		-4,416	-10,061
<b>Total comprehensive income</b>		<b>-19,172</b>	<b>-24,095</b>
of which attributable to non-controlling interests		646	-5
of which attributable to shareholders of H&R AG		<b>-19,818</b>	<b>-24,090</b>

## Consolidated statement of changes in shareholders' equity

## Consolidated statement of changes in shareholders' equity of H&R AG

as of 31 December 2014

€ THOUSAND	Subscribed capital	Capital reserves	Retained earnings
<b>31/12/2012</b>	<b>76,625</b>	<b>18,599</b>	<b>117,724</b>
Dividends			
Income after taxes			-14,029
Other comprehensive income			-862
Total comprehensive income			-14,891
<b>31/12/2013</b>	<b>76,625</b>	<b>18,599</b>	<b>102,833</b>
Capital increase	14,948	24,730	
Dividends			-
Income after taxes			-15,402
Other comprehensive income			-13,658
Total comprehensive income			-29,060
<b>31/12/2014</b>	<b>91,573</b>	<b>43,329</b>	<b>73,773</b>

## Consolidated statement of changes in shareholders' equity

Comprehensive income						Total
Revaluation surplus		Foreign currency translation differences	Equity share attributable to H&R AG shareholders	Non-controlling shares		
Market valuation of financial assets	Cash flow hedges					
139	-4,740	4,984	213,331	-48		213,283
				-26		-26
			-14,029	-8		-14,037
-8	993	-10,184	-10,061	3		-10,058
-8	993	-10,184	-24,090	-5		-24,095
131	-3,747	-5,200	189,241	-79		189,162
			39,678	39,235		78,913
			-	-		-
			-15,402	-206		-15,608
134	950	8,158	-4,416	852		-3,564
134	950	8,158	-19,818	646		-19,172
265	-2,797	2,958	-209,101	39,802		248,903

## Consolidated cash flow statement

## Consolidated cash flow statement of H&amp;R AG

1 January 2014 to 31 December 2014

€ THOUSAND		2014	2013
1.	Income after taxes	-15,608	-14,037
2.	Income taxes	7,777	-2,812
3.	Net interest result	13,811	16,163
4.	+/- Depreciation, impairment and amortization	25,639	36,734
5.	+/- Changes in non-current provisions	-2,489	-5,309
6.	+ Interests received	512	291
7.	- Interests paid	-10,529	-11,914
8.	+/- Income taxes paid/received	-7,090	1,915
9.	+/- Other non-cash expenses and income	-1,846	-1,817
10.	+/- Increase/decrease in current provisions	-1,825	-1,202
11.	-/+ Result from the disposal of fixed assets	-4	63
12.	-/+ Changes in net working capital	2,196	82,206
13.	+/- Changes in remaining net assets / other non-cash items	-10,908	-11,339
14.	= <b>Cash flow from operating activities (sum of 1 to 13)</b>	<b>-364</b>	<b>88,942</b>
15.	+ Proceeds from disposal of tangible fixed assets	201	108
16.	- Payments for investments in tangible fixed assets	-19,189	-16,131
17.	- Payments for investments in intangible assets	-313	-146
18.	+ Receipts from acquisitions	9,233	-
19.	- Payments for investments in financial assets	-19	-
20.	= <b>Cash flow from investing activities (sum of 15 to 19)</b>	<b>-10,087</b>	<b>-16,169</b>
21.	= <b>Free cash flow (sum of lines 14 and 20)</b>	<b>-10,451</b>	<b>72,773</b>
22.	- Dividends paid by H&R AG	-	-
23.	+ Receipts from capital increase of Non-controlling shareholders	4,974	-
24.	+ Dividends received from joint ventures	284	287
25.	- Dividends paid to non-controlling interests	-	-26
26.	- Payments resulting from the settlement of financial debt	-26,307	-49,643
27.	+ Receipts from the taking up of financial debt	20,794	145
28.	= <b>Cash flow from financing activities (Sum of 22 to 27)</b>	<b>-255</b>	<b>-49,237</b>
29.	+/- Cash and cash equivalent changes in the financial resources fund (sum of lines 14, 20, 28)	-10,706	23,536
30.	+ Cash and cash equivalents at the start of the period	109,624	89,588
31.	+/- Changes in scope of consolidation	-	-
32.	+/- Change in cash and cash equivalents due to changes of exchange rates	2,640	-3,500
33.	= <b>Cash and cash equivalents at the end of the period</b>	<b>101,558</b>	<b>109,624</b>

# Notes to the Consolidated Financial Statements of H&R AG

as of 31 December 2014

## (1) General information

H&R AG, a listed company headquartered at 48499 Salzbergen (Germany), Neuenkirchener Strasse 8, does business in various specialty chemical and plastics markets via its subsidiaries. The Group's businesses include the production of chemical-pharmaceutical raw materials as well as the manufacture of injection-molded precision plastic parts.

As a stock exchange listed Group parent company, H&R AG, pursuant to Article 315a of the German Commercial Code (HGB), is under the obligation to prepare consolidated financial statements in accordance with international accounting standards and rules. The consolidated financial statements of H&R AG were prepared based on the accounting rules of the International Accounting Standards Board (IASB), whose application was mandatory under EU Regulation No. 1606/2002 as of the balance sheet date, and according to the additionally applicable rules of Article 315a (1) of the HGB. The requirements of the Standards (IFRS/IAS) and interpretations (IFRIC/SIC) whose application was mandatory as of the balance sheet date were met without exception.

H&R Holding GmbH, Hamburg, prepares the consolidated financial statements for the largest scope of the companies in which H&R AG is directly included via H&R Beteiligung GmbH, Hamburg.

The changes in H&R AG's shareholders' equity are shown, along with the income statement, the consolidated statement of comprehensive income, the balance sheet and the cash flow statement. Individual, summarized positions are discussed in greater detail in the notes. The income statement is prepared in accordance with the total-cost method. The balance sheet is broken down into current and non-current assets and liabilities. Under this approach, assets are shown under current assets when they are held for trading purposes, are intended for sale within the normal course of the business cycle or are expected to be sold within 12 months of the balance-sheet date. Debts are classified as current liabilities in a similar way. Pension provisions as well as deferred tax claims and/or liabilities are in principle treated as being non-current.

The 2014 consolidated financial statements were prepared using the euro (€) as the functional currency. Unless stated otherwise, all amounts are shown in thousands of euros (€ thousand). Rounding can lead to the amounts mentioned in this report not adding up exactly to the sums stated, and to percentages not exactly matching the amounts reported.

The financial year of H&R AG and the subsidiaries included in the consolidated financial statements coincides with the calendar year.

The consolidated financial statements are published in the Federal Gazette [Bundesanzeiger].

## Notes

## (2) Effects of the new accounting standards

## (2) Effects of the new accounting standards

STANDARDS AND INTERPRETATIONS TO BE APPLIED FOR THE FIRST TIME IN THE CURRENT FINANCIAL YEAR. The International Accounting

Standards Board (IASB) published changes to the following Standards whose application is mandatory for the first time in the current financial year, 2014:

Standard/ Interpretation	Title	Mandatory application pursuant to IASB/EU Regulation	Imple- mentation by the EU	Essential effects on H&R
IAS 27	Amendment: Separate Financial Statements (revised 2011)	1/1/2014	11/12/2012	none
IAS 28	Amendment: Investments in Associates and Joint Ventures (revised 2011)	1/1/2014	11/12/2012	none
IAS 32	Amendment: Offsetting Financial Assets and Financial Liabilities	1/1/2014	13/12/2012	none
IAS 36	Impairment of Assets – Recoverable Amount Disclosures for Non-Financial Assets	1/1/2014	19/12/2013	see notes
IAS 39	Novation of Derivatives and Continuation of Hedge Accounting	1/1/2014	19/12/2013	none
IFRS 10	Consolidated Financial Statements	1/1/2014	11/12/2012	see notes
IFRS 11	Joint Arrangements	1/1/2014	11/12/2012	see notes
IFRS 12	Disclosure of Interests in Other Entities	1/1/2014	11/12/2012	see notes
	Transition Guidance: Amendments to IFRS 10, IFRS 11 and IFRS 12	1/1/2014	4/3/2013	none
	Amendments to IFRS 10, IFRS 12 and IAS 27 for Investment Entities	1/1/2014	20/11/2013	none
	Transition Guidance: Amendments to IFRS 10, IFRS 11 and IFRS 12	1/1/2014	4/4/2013	none

In May of 2013, the IASB published changes to IAS 36 (Impairment of Assets) concerning required disclosures of impairments to non-financial assets. The endorsement by the EU took place on 19 December 2013. The change led to a correction of the required disclosures pursuant to IAS 36 regarding the disclosure of the recoverable amount for cash-generating units (CGUs) in the event of impairment losses or reversals of impairment losses. The change is to be applied for financial years beginning on or after 1 January 2014. Advance implementation was possible and H&R AG took advantage of this option. As a result, only the recoverable amount of the CGU that is affected by an impairment is stated in the notes.

IFRS 10 (Consolidated Financial Statements) introduces principles for the preparation and presentation of consolidated financial statements for businesses that control one or more other businesses. The Standard defines a uniformly applicable principle of control and establishes control as the basis for consolidation. IFRS 10 replaces

the pertinent rules from IAS 27 (Consolidated and Separate Financial Statements) and SIC-12 (Consolidation – Special Purpose Entities). The implementation of IFRS 10 has not resulted in any changes to H&R AG's consolidated group.

IFRS 11 (Joint Arrangements) regulates the preparation of balance sheets of joint ventures through which the joint control can be carried out together with a third party. The joint ventures can be differentiated as Joint Operations and Joint Ventures. With joint operations, future pro-rated assets and debts as well as revenues and expenses are to be recorded in accordance with the rights and obligations of the individual parties. In the future, the share in a joint venture is to be recorded by one of the partners using the equity method. The first-time application of IFRS 11 has no effect on the presentation of the net assets, financial position and results of operations of H&R AG, because the joint ventures are already recorded in accordance with the equity method and there are no joint operations.

The first-time application of IFRS 12 requires expanded disclosures in the notes about interests in subsidiaries, associates, joint arrangements and structured entities.

The application of the new accounting rules had no material impact on the presentation of the company's net assets, financial position and results of operations or on earnings per share.

PUBLISHED STANDARDS AND INTERPRETATIONS THAT ARE NOT YET BEING APPLIED. As of the balance sheet date, the following accounting standards had already been published by the International Accounting Standards Board (IASB) and the International Financial Reporting Interpretations Committee (IFRIC) but application of the standards was not yet mandatory.

#### PUBLISHED STANDARDS AND INTERPRETATIONS THAT ARE NOT YET BEING APPLIED

Standard/ Interpretation	Title	Mandatory application pursuant to IASB/EU Regulation	Implementation by the EU	Essential effects on H&R
IAS 19	Amendment to IAS 19: Employee Benefits	1/7/2014	17/12/2014	none
IFRS 9	Financial Instruments	No sooner than 1/1/2018	Expected in H2 2015	not foreseeable
IFRS 14	Regulatory Deferral Accounts	1/1/2016	Postponed	none
IFRS 15	Revenue from Contracts with Customers	1/1/2017	Expected in Q2 2015	none
	Amendments to IFRS 10, IFRS 12 and IAS 28: Investment Entities	1/1/2016	Expected in Q4 2015	none
	Amendments to IAS 1	1/1/2016	Expected in Q4 2015	none
	Annual Improvements to IFRSs (2010-2012)	1/7/2014	17/12/2014	none
	Annual Improvements to IFRSs (2011-2013)	1/7/2014	18/12/2014	none
	Annual Improvements to IFRSs (2012-2014)	1/1/2016	Expected in Q3 2015	none
	Amendments to IFRS 10 and IAS 28	1/1/2016	Expected in Q4 2015	none
	Amendment to IAS 27 – Application of the Equity Method in Separate Financial Statements	1/1/2016	Expected in Q3 2015	none
	Amendments to IAS 16 and IAS 41 – Bearer Plants	1/1/2016	Expected in Q3 2015	none
	Amendments to IAS 16 and IAS 38 – Clarification of Acceptable Methods of Depreciation and Amortization	1/1/2016	Expected in Q3 2015	none
	Amendment to IFRS 11 – Acquisition of an Interest in a Joint Operation	1/1/2016	Expected in Q3 2015	none
IFRIC 21	Levies	17/6/2014	13/6/2014	none

### (3) General balance sheet preparation and evaluation methods

The consolidated financial statements were prepared on the basis of historical acquisition and manufacturing costs, with the exception of items valued at their fair value, such as derivative financial instruments and financial assets held for trading purposes or available for sale.

PRINCIPLES OF CONSOLIDATION. The accounts included in the consolidated financial statements are prepared in accordance with uniform accounting and valuation methods. The closing date is the closing date of the parent company.

Subsidiaries are companies in which H&R AG has a direct or indirect majority of the voting rights. They are first included in the consolidated financial statements when H&R AG obtains the power to control. If this power to control ceases, the companies in question are removed from the group of consolidated companies.

**Notes**

## (3) General balance sheet preparation and evaluation methods

All Group internal business transactions and interim results as well as claims and liabilities existing between consolidated companies are eliminated in the course of consolidation. Deferred income tax effects arising from the consolidation process are appropriately taken into account.

In accordance with IFRS 3 (Business Combinations), company mergers are recorded in the financial statements using the acquisition method. In this connection, the acquirer is deemed to be the party that has obtained control over the acquired company and is therefore in a position to derive benefits from the acquired business. In the case of a company purchase, the pro-rata equity of the acquired subsidiary is determined at the time of acquisition, taking into account the fair values of the identifiable assets, debts and contingent liabilities, deferred taxes and the value of any goodwill at that time. If foreign companies are acquired, the acquisition costs are converted into euros at the respective exchange rate on the purchase date.

The acquisition costs correspond to the fair value of the transferred assets, the equity instruments issued and the debts arising and/or being assumed at the time of the transaction. In addition, they contain the fair values of any reported assets or debts resulting from a conditional consideration arrangement. Purchase-related ancillary costs are immediately recorded as a charge against income.

Acquisition costs are offset against the pro-rata fair value of the net equity. Net equity is determined by assessing the identified assets, debts and contingent liabilities of the acquired company at the time of acquisition at their fair value. Any amount remaining on the asset side after set-off is treated as goodwill. Pursuant to IFRS 3, any negative amount resulting from revaluation of the net assets acquired is immediately charged against income.

Non-controlling interests in fully consolidated companies are valued at the pro-rata fair value of the net assets. Transactions with non-controlling

interests are treated like transactions with Group equity owners. The difference between the acquired pro-rata equity of other shareholders and the purchase price is therefore directly netted against equity.

**SHARES IN HOLDINGS VALUED AT EQUITY.** Interests in associates and in joint ventures are reported in accordance with the equity method. Joint ventures are companies that H&R AG manages jointly with a third party. With associates, H&R AG's interest is between 20% and 50%. Under the equity method, the carrying value of holdings valued at equity is increased or reduced by the change in equity corresponding to H&R AG's interest in the equity of these companies. The Group's interest in associated companies and in joint ventures is the goodwill value generated by the acquisition. The changes in the pro-rata equity affecting the income statement are recognized in the profit or loss resulting from holdings valued at equity. For companies whose financial statements are prepared in accordance with the equity method, an impairment loss must be recognized if the recoverable amount is below the carrying amount. As of 31 December 2014, three joint ventures were being accounted for using this method.

**CURRENCY TRANSLATION.** The annual financial statements of the foreign subsidiaries are converted into euros in accordance with the functional-currency principle. As the companies essentially manage their business independently from a financial, economic and organizational point of view, the respective functional currency as a rule is that of the country in which the company is headquartered.

In the separate financial statements of the Group companies, foreign currency transactions are translated into the functional currency at the exchange rates in effect at the time of the transaction. On the balance sheet, receivables and payables in foreign currencies are valued at the exchange rate on the balance-sheet date; the resulting exchange-rate gains and losses are recognized on the income statement.



In the consolidated financial statements, the assets and liabilities are converted into euros at the exchange rate on the respective balance-sheet date. Any changes taking place during the year, as well as profit and loss items, are converted into euros at the average annual exchange rate. With the exception of revenues and expenses directly recognized in equity, the shareholders' equity is

carried at historical exchange rates. The resulting variances are recognized in equity but are not reported on the income statement until the subsidiary is sold.

The exchange rates used for the foreign currency translation have changed as follows:

#### EXCHANGE RATES FOR THE MAIN CURRENCIES

	Exchange rate on the balance sheet date 31/12/2014	Exchange rate on the balance sheet date 31/12/2013	Average rate 2014	Average rate 2013
US dollar	1.2141	1.3791	1.3288	1.3282
British pound	0.77890	0.8337	0.80643	0.84925
Australian dollar	1.4829	1.5423	1.4724	1.3770
South African rand	14.0353	14.566	14.4065	12.8308
Thai baht	39.910	45.178	43.163	40.8233
Chinese yuan	7.5358	8.3491	8.1883	8.1655
Czech crown	27.735	27.427	27.536	25.987
Malaysian ringgit	4.2473	4.5221	4.3472	4.1855

**CASH AND CASH EQUIVALENTS.** Cash and cash equivalents comprise cash in hand, checks received and credit balances at banks and have a maximum term of three months at the time of acquisition or investment. Cash and cash equivalents are valued at acquisition cost.

**FINANCIAL INSTRUMENTS.** Financial instruments are contractually agreed claims or obligations that lead to an incoming or outgoing flow of financial assets or to the issuance of equity capital rights. They also comprise derivative claims or obligations from underlying financial instruments. According to IAS 39, financial instruments are recognized on the income statement at the point in time of inclusion in the following valuation categories: financial assets or liabilities at fair value through profit and loss, loans and receivables, available-for-sale financial assets and held-to-maturity investments, as well as other liabilities.

**FINANCIAL ASSETS.** Financial assets comprise cash and cash equivalents, loans issued and receivables, equity and debentures acquired and derivatives with positive fair values.

The recognition and valuation of financial assets follow the criteria stipulated in IAS 39. According to these criteria, financial assets are recognized on the balance sheet when H&R AG has a contractual right to receive cash or other financial assets. Financial assets are booked at the value on the trading day on which the Group has committed to the purchase of the asset. Financial assets are categorized according to their initial recognition. Loans and receivables as well as financial assets available for sale are first booked at their fair value plus transaction costs.

Loans and receivables are non-derivative financial assets with contractually fixed or determinable payments that are not quoted on an active market. They are shown on the balance sheet under trade receivables and other financial assets. Loans and receivables are subsequently measured at amortized cost using the effective-interest method. If there are objective and substantial signs of an impairment in value, an impairment test is carried out. Signs of an impairment in value include, among others, the high probability of insolvency proceedings, significant financial difficulties of a

**Notes**

## (3) General balance sheet preparation and evaluation methods

debtor or the disappearance of an active market for financial assets.

Financial assets available for sale are non-derivative financial assets that were either specifically and explicitly assigned to this category or that could not be assigned to any other category of financial assets. After their initial recognition, available-for-sale financial assets are measured at fair value. Changes in fair value are recognized in equity, without any effect on profit or loss, until the assets are disposed of. Permanent impairment losses are reported on the income statement. Reversals of the impairment losses are offset against equity without any effect on profit or loss, unless they concern a debt instrument and the reversal of the impairment loss relates to an impairment loss previously recognized through profit or loss. If no fair value can be determined, the interests are valued at amortized cost.

The financial assets valued at fair value and recognized through profit or loss concern securities classified as current assets as well as derivative financial instruments with a positive fair value not included in a hedge (Hedge Accounting).

Assets are derecognized at the time of the extinction and/or the transfer of the rights to payments arising out of the asset and thus at the point in time at which essentially all risks and opportunities related to ownership were transferred. Before derecognizing receivables that are legally transferred within the scope of receivables sales, H&R AG tests the criteria for derecognition in accordance with the applicable rules. If the criteria are not met, the receivables remain on the balance sheet. There is no full disposal if essentially all the risks and opportunities were neither retained nor transferred and the power of control over the receivables remains with the transferor. In this case, only a partial disposal of the receivables should be booked, taking into account the remaining continuing involvement. Continuing involvement is the extent to which the transferor is still exposed to fluctuations in the value of the receivables.

Financial assets and financial liabilities are not offset, apart from the reimbursement right against BP (see explanation (9) and (19)), since no such offset agreements exist.

**DERIVATIVE FINANCIAL INSTRUMENTS.** Derivative financial instruments are used in order to reduce currency and interest-rate risks, e.g. in the form of forward currency contracts and interest-rate swaps.

Derivative financial instruments are carried on the balance sheet at fair value and, depending on the market value, are shown as financial assets or liabilities. The fair value of the derivatives is calculated using standard market valuation methods, taking into account the market data available on the valuation date. With forward currency contracts, the valuation is carried out on a case-by-case basis at the pertinent forward exchange rate and/or price on the balance-sheet date. The fair value of derivative financial instruments for interest-rate hedging is determined by discounting future incoming and outgoing cash flows. Standard market interest rates which have been adjusted to reflect their own credit risk and which correspond to the respective time to maturity of the financial instruments are used for discounting. To the extent expedient, derivative financial instruments that satisfy hedge accounting criteria pursuant to IAS 39 are designated either to hedge the fair value of an asset or a debt (fair-value hedge) or to hedge the risk of fluctuating cash flows from future transactions that are very likely to occur (cash-flow hedge). If derivative financial instruments do not satisfy the criteria for hedge accounting, they are, in accordance with IAS 39, classified as held for trading and recognized in profit or loss on the income statement. The changes in the fair value of derivatives intended as fair-value hedges are recognized on the income statement along with the changes in the fair value of the hedged assets or liabilities allocable to the hedged risk. In these annual financial statements, there were no fair value hedges of assets or liabilities.

The effective portion of changes in the fair value of derivatives designated as cash-flow hedges to hedge payment streams is recognized under other profit/(loss) without any effect on the income statement. By contrast, the ineffective portion of such changes in value is recognized directly in profit or loss on the income statement. Amounts deferred or accrued in other profit/(loss) are re-posted to the income statement and are recognized as income or expense during the period in which the underlying transaction being hedged affects profit or loss. When a hedge expires, is disposed of or no longer satisfies the criteria for being carried on the balance sheet as a hedge, the cumulative profit or loss up to that date recognized in other profit or loss remains part of equity and is only reclassified to the income statement with an effect on profit or loss if the originally hedged future transaction takes place. If the future transaction is no longer expected to take place, the cumulative gains and/or losses that are recorded under equity with no effect on income or loss must immediately be recognized in profit or loss.

**INVENTORIES.** According to IAS 2, inventories include those assets held for sale in the ordinary course of business (finished products and merchandise), assets in the production process with a view to being sold (work in process) or materials and supplies that are consumed in the scope of the manufacture of products or the provision of services (raw, auxiliary and production materials). Inventories are stated at the lower of acquisition or manufacturing cost and the net realizable value, as determined on the basis of the weighted-average-cost method, i.e. at the sales price that can be obtained in the normal course of business less the estimated manufacturing and marketing costs. Manufacturing costs comprise the material and production costs directly allocable to the manufacturing process, directly allocable portions of the material and manufacturing overhead costs and production-oriented general and administrative overhead costs. Raw, auxiliary and production materials are not depreciated if the end products can be sold at a profit. By-products

are stated at fair value. Borrowing costs are not taken into account.

**PROPERTY, PLANT AND EQUIPMENT.** Tangible fixed assets are valued at acquisition or manufacturing costs less cumulative depreciation and impairment losses. The option to revalue tangible fixed assets pursuant to IAS 16.31 was not used.

Acquisition costs consist of the price of the acquisition, the ancillary acquisition costs and subsequent acquisition costs less acquisition price reductions obtained. Expenses for the ongoing repair and maintenance of tangible fixed assets are included in profit or loss. Expenses for renewal and maintenance are capitalized as subsequent manufacturing costs only if they result in a substantial extension of the useful life, a significant improvement or a meaningful change in the use of the fixed asset.

Expenses related to scheduled shutdowns of large facilities are stated separately at the amount of the costs of the measure as part of the facility in question and are depreciated on a straight-line basis over the period until the next scheduled shutdown. To the extent that depreciable property consists of essential identifiable components with individually different useful lives, such components are carried separately and depreciated over their respective useful lives. Investment subsidies are deferred and recognized as income over the average useful lives of the subsidized assets.

Depreciable fixed assets are subject to scheduled straight-line depreciation over their respective useful lives; residual amounts are taken into account. These useful economic lifespans are reviewed on each balance-sheet date and adjusted, if necessary. Upon sale or retirement, the acquisition or manufacturing costs and the relevant accumulated depreciation of the facilities are derecognized; the resulting gains or losses are recognized in profit or loss. The useful lifespans used can be summarized as follows:

**Notes**

## (3) General balance sheet preparation and evaluation methods

<b>ASSETS</b>	
	<b>Useful economic life</b>
Buildings	10 to 50 years
Land using rights	50 years
Tank farms	25 years
Technical equipment and machinery	10 to 20 years
Other facilities	3 to 6 years
Operating and office equipment	3 to 13 years

**BORROWING COSTS.** Essentially, the cost of borrowed capital is recognized in profit or loss in the period in which the external capital expense is incurred. According to IAS 23, borrowing costs that are directly attributable to the construction, acquisition or production of a qualifying asset form part of the cost of that asset and, therefore, should be capitalized. In financial year 2014, as in the previous year, no interest was paid on borrowed capital.

**LEASING.** A lease is an agreement whereby the lessor, in return for a payment or series of payments, conveys to the lessee the right to use an asset for a specific period of time. Leasing transactions are classified either as finance leases or as operating leases. If the H&R Group, as the lessee in leasing transactions, bears all essential risks and opportunities related to ownership, then such transactions are treated as finance leases. In that case, the Group capitalizes the leased property at the lower of the fair value and the present value of the minimum lease installments and thereafter depreciates the leased property over the shorter of the estimated useful life or the lease term. At the same time, a matching financial liability is recognized at the lower of the fair value of the leased property and the present value of the minimum lease installments; interest and principal payments will subsequently be made, and the liability adjusted accordingly, using the effective-interest method. All remaining lease agreements in which the Group is the lessee or lessor are treated as operating leases. In this case, lease payments made are recorded under expenses and lease payments received are recorded as income.

The asset leased out by H&R AG continues to be shown under property, plant and equipment on the balance sheet.

**GOODWILL.** The first time it is reported, the goodwill resulting from a merger is stated at the acquisition cost, which is measured as the surplus of the value of the consideration transferred over the identifiable assets acquired and liabilities assumed. After the first-time recognition, goodwill is measured at acquisition cost less accumulated impairment losses.

Goodwill is not subject to scheduled amortization, but, rather, is subjected to an impairment test every year. If any events or changed circumstances that indicate a potential impairment loss should be identified, the impairment test is also carried out more frequently. In the event of the need to recognize a goodwill impairment loss, it is immediately recognized under depreciation and amortization on the income statement. Reversal of an impairment loss for goodwill in later periods is not allowed.

The annual goodwill impairment tests take place at the level of the cash-generating units (CGUs) that are relevant for the test. The cash-generating unit represents the lowest level at which goodwill is monitored for internal management purposes. H&R AG essentially considers both strategic business units under standard management with comparable product portfolios and, sporadically, also individual, legally autonomous companies to be cash-generating units. Goodwill impairment is determined by comparing the carrying amount of the cash-generating unit, including the goodwill to be allocated to it, with the recoverable amount for the cash-generating unit. The recoverable amount is the higher of fair value less costs of disposal and the value in use. The recoverable amount here is the value in use determined using the discounted-cash-flow method. If the carrying amount exceeds the Division's recoverable amount, an impairment loss equal to the difference must be recognized on the income state-

ment. If the calculated impairment loss is equal to or higher than the carrying amount of the goodwill, the goodwill must be written off entirely. The remaining impairment loss is, as a rule, allocated proportionally to the remaining non-current assets of the cash-generating unit.

The expected cash flows of the cash-generating units are derived from H&R Group's five-year plan. For subsequent periods, the cash flow was extrapolated using the prior-year approach, with an expected growth rate of 1% p.a. The plan is based, in particular, on assumptions concerning the trend in sales revenues, the material-usage ratio and investments already initiated, as well as on empirical values and market expectations. Pursuant to IAS 36, investments to expand capacity for which to date no cash outflows have occurred are not included. The assumed price level for crude oil of US\$110 per barrel (Brent) used in the budget was based on market estimates made by financial institutions. In addition, a stable pricing differential was assumed for a number of finished-product prices for all five plan years.

Average costs of capital were used for the discounted cash flow; these capital costs are calculated based on market values. The after-tax discount rates used were 6.1% in the Chem-Pharm Refining segment (previous year: 6.9%) and between 6.3% and 10.8% in the Chem-Pharm Sales segment (previous year: between 7.3% and 11.2%). That is equal to pre-tax interest rates of 8.5% in the Chem-Pharm Refining segment (previous year: 8.8% and 8.9%) and 8.3% to 15.0% in the Chem-Pharm Distribution segment (previous year: 9.4% to 14.9%). Differences in the individual cash-generating units' cost of capital result in particular from various assumptions and estimates concerning country risk, credit risk and price inflation in the country in which the cash-generating unit is headquartered.

**OTHER INTANGIBLE ASSETS.** Other intangible assets are capitalized at their acquisition or manufacturing costs. Insofar as they have determinable

useful lives, they are subject to scheduled depreciation on a straight-line basis over their respective useful lives. The following useful life spans were assumed in determining scheduled depreciation:

#### ASSETS

	Useful life
Software	3 to 5 years
Licences	3 to 5 years
Concessions and Patents	3 to 10 years

The H&R Group has received CO<sub>2</sub> emission rights free of charge in connection with the introduction of emissions trading in the European Union; they are valued at a zero acquisition cost. Any expenses that arise in connection with the registration of products pursuant to the EU Chemicals Regulation (REACH) are capitalized under other intangible assets and amortized over an expected useful life of 10 years.

Permanent impairment losses to other intangible assets are accounted for under unscheduled depreciation and amortization. In the event the reasons for unscheduled depreciation/amortization no longer apply, the appropriate write-ups are effected to the extent that the amortized costs are not exceeded. The reasons for unscheduled depreciation/amortization are reviewed on each balance-sheet date.

Intangible assets with an unlimited useful life are not subject to scheduled amortization; instead, an annual impairment test is carried out on such assets.

**RESEARCH AND DEVELOPMENT COSTS.** Research expenses are recognized as expenses in the period in which they are incurred. Development expenses are capitalized only if the requirements of IAS 38 have been satisfied. According to this Standard, capitalization is always required when there is reasonable certainty that the development activity will lead to future cash flows that will also cover the relevant development costs. As internal devel-

**Notes**

## (3) General balance sheet preparation and evaluation methods

opments are subject to various uncertainties, the conditions for capitalizing costs incurred in bringing a product to market generally are not met.

**FINANCIAL LIABILITIES.** Financial liabilities include liabilities to banks, trade payables and derivatives with negative fair values, as well as other financial liabilities.

When first reported, financial liabilities are always stated at their fair value and after deduction of transaction costs. In subsequent periods, they are measured at amortized cost using the effective-interest method.

Financial liabilities are derecognized when the contractual obligations are settled, reversed or have expired.

**OTHER RECEIVABLES AND LIABILITIES.** Accruals and deferrals and other non-financial assets and liabilities are initially recognized at amortized cost. Reversal takes place on a straight-line basis or using the percentage-of-completion method.

Government grants for assets are shown on the balance sheet as deferrals in the other liabilities section and are reversed and recognized in profit or loss over the average useful life of the subsidized assets. Private subsidies are recognized as other liabilities under both current and non-current liabilities and are reversed over their expected useful lives.

**PENSIONS AND SIMILAR OBLIGATIONS.** Company pensions of the H&R Group are designed based on the legal, tax and economic circumstances in the respective countries and include both defined-contribution and defined-benefit plans. Under defined-contribution plans, the Group makes contributions to public or private pension-insurance plans based on a statutory or contractual obligation or even voluntarily. The Group has no further payment liabilities beyond payment of the contributions. Contributions are recognized under personnel expenses when due.

The present value of the pension commitments under defined-benefit pension plans (defined-benefit obligations, DBOs) and of the associated past service expense is calculated using the Projected Unit Credit Method. Under this method, the valuation is based on actuarial calculations for which specific assumptions must be made concerning salary and pension payment trends, turnover rates and death rates, as well as interest rates. Due to changing conditions, the actual future expenses and liabilities can differ significantly from the estimates in the actuarial report.

Under defined-benefit pension plan accounting rules, interest expense is recognized under net interest result on the income statement. Past service expenses are recorded as personnel expenses. Effects from the remeasurement of defined-benefit pension plans are recognized directly in equity and on the statement of comprehensive income, where deferred taxes are taken into account. The fair value of the plan's assets is deducted from the present value of the pension obligations recorded on the balance sheet. The plan's assets consist of a reinsurance policy for the pension commitment to a former director that is measured at fair value. If the plan's assets exceed the corresponding pension liability, the excess amount is shown as "Other receivable" subject to the upper limit set in IAS 19R.

**OTHER PROVISIONS.** Other provisions are established in accordance with IAS 37 if, on the basis of a past event, a current, legal or factual obligation exists, settlement is likely to result in an outflow of resources with economic benefits and a reliable estimate of the amount of the liability is possible. The amount set up as a provision represents the best estimate of the amount required to settle the present obligation as of the balance-sheet date. In the event of a significant interest-rate effect, the present value of the expected expenses is used.

The anniversary provisions are valued according to the projected unit credit method pursuant to IAS 19R. Contractual obligations under lease agreements (e.g. demolition, renovation or



eviction) are recognized on the balance sheet as provisions, insofar as the expected utilization of resources with an economic benefit is likely. Provisions for impending losses resulting from unfavorable contracts are set up when the expected economic benefit resulting from the contract is lower than the costs that are unavoidable in order to satisfy the contractual obligations.

Restructuring provisions are created in accordance with IAS 37.70 et seq. as soon as a detailed, formal restructuring plan is available and a justified expectation has been created in the affected parties that the restructuring measures will take place in regard to the affected parties by starting to implement the plan or by announcing its essential components.

The annual obligations to return emission rights based on the actual CO<sub>2</sub> emissions of the refineries are at first covered by the emission certificates received free of charge and are valued at their acquisition cost, which is equal to zero. In the event that the emissions rights assigned free of charge should not suffice, provisions for the additional emissions rights that will have to be acquired will be set up at the expected acquisition cost.

**RECOGNITION OF REVENUE.** The proceeds from products sold and services rendered as part of the company's usual business activities are recognized as sales revenues. Other operating earnings are shown as other operating income.

Sales revenues and other operating income are recognized when the service is provided or when the risk is transferred to the customer or when the claim originates. Moreover, sales revenues are also realized from sales in which legal ownership has been transferred to the customer but delivery has been postponed at the customer's request. Ultimately, it must be possible to determine the amount of the sales in a reliable manner and it must be possible to assume that the receivable is recoverable. Sales revenues are reported after deducting value-added tax, reductions in

selling price such as returns, discounts or price reductions and after eliminating intercompany sales. Operating expenses are recognized when they are incurred. Interest income and interest expense are recognized in income or loss on an accrual basis. Interest expense relating to lease agreements is recorded using the effective-interest method. Dividends to which Group companies are entitled are recognized on the date when the dividend right arises. Intercompany transactions are conducted as arm's-length transactions.

**INCOME TAX.** Income taxes comprise both the taxes levied in the individual countries on taxable profits and changes in deferred taxes that have an effect on profit or loss. The current tax expense is based on the taxable income determined in accordance with the tax regulations of the respective country for the year, taking into account the applicable tax rate in that jurisdiction. Pursuant to IAS 12, deferred taxes reflect differences between the time when asset and liability amounts are reported in the consolidated financial statements under accounting rules and the time when the corresponding amounts are reported under tax rules governing the determination of taxable income. Current and deferred taxes are essentially recognized in profit or loss, unless they are related to circumstances recognized in other income/loss. In that case, the current and deferred taxes are also recognized in other income/loss.

Deferred tax assets pertaining to deductible temporary differences and loss carryforwards are recognized to the extent it is probable that sufficient taxable profit will be available against which the temporary differences and still unused loss carryforwards can be utilized. This is based on individual company forecasts of the income situation of the Group company concerned. The amount of deferred tax assets recognized for temporary differences and tax-loss carryforwards is determined on the basis of future taxable income within a forecast period of five years. In Germany, the unlimited carryforward option for domestic losses is limited by the minimum taxation level. For

**Notes**

## (4) Discretionary decisions and estimates

foreign loss carryforwards, there are often country-specific time limitations on the carryforward option and restrictions on the use of profits from operating activities.

Deferred tax liabilities arising from temporary differences in holdings in subsidiaries and associated companies are recognized unless the date of the reversal of the temporary differences can be determined by the Group and it is probable that the temporary differences will not be reversed within a foreseeable period of time due to this influence.

When determining the deferred taxes, the expected tax rates in specific countries at the time of the expected realization are assumed.

Deferred tax receivables and liabilities are netted if the deferred tax receivables and liabilities refer to income taxes levied by the same tax authority for either the same taxpayer or for different taxpayers intending to effect settlement on a net basis.

**CONTINGENT LIABILITIES.** Contingent liabilities are potential obligations toward third parties or current commitments in which a cash outflow is unlikely and/or its amount cannot be determined in a reliable manner. In principle, contingent liabilities are not reported on the balance sheet. The liability amounts stated in the notes under contingent liabilities match the scope of liability in effect on the balance-sheet date.

**(4) Discretionary decisions and estimates**

In preparing the consolidated financial statements, to a certain extent assumptions and estimates must be made that will affect the asset and liability, income and expense and contingent liability amounts reported for the period under review. Estimates are based on empirical values and other assumptions that are deemed to be appropriate given the circumstances.

Assumptions and estimates are used in particular in testing intangible assets for impairment, in determining overhead surcharges when valuing inventories, in determining the useful economic lives of assets throughout the group in a uniform manner, in estimating the recoverability of receivables and in reporting and valuing provisions. Moreover, discretionary decisions and estimates are necessary in testing intangible assets for impairment and in measuring the amount of deferred tax assets relating to loss carryforwards to recognize. Further details on the individual items can be found in each section.

Signs pointing to an impairment loss, as well as recoverable amounts and fair values identified, are also combined with estimates. These include, in particular, estimated future cash flows, the applicable discount rates, the expected useful lives and residual values.

For sensitivity analyses, generally a possible fluctuation range of 10% is assumed, as a change of up to this amount seems possible, especially over the long term. Sensitivity analyses were carried out in particular for the goodwill impairment tests at the level of the cash-generating units and in connection with financial instruments. For pension provisions, the sensitivity analysis assumes a 50-basis-point change in the interest rate and a 25-basis-point change in the pension trend.

Other essential assumption factors are the discount rate and the underlying mortality tables in connection with the pension provisions and similar commitments, as well as the estimates of necessary expenditures for the circumstances taken into account for other provisions. This also concerns the possibility of a cash outflow due to dismantling obligations, which is described in greater detail in note (39). Details on sensitivity analyses in the area of pension provisions can be found in note (19).



The assumptions and estimates are based on currently available information. In addition, the trends in the economic environment in the industries and regions in which the Group does business, which are currently assumed to be realistic, were also taken into account in regard to expected future business developments. Developments in these macroeconomic conditions that deviate from the assumptions and are outside of Management's control may cause the actual amounts to deviate from the original estimates. In such cases, the assumptions and, if required, the carrying amounts of the assets and liabilities affected will be adjusted accordingly.

China Holding GmbH, the following companies were also added to the consolidated group: H&R China (Ningbo) Co. Ltd., H&R China (Daixi) Co. Ltd., H&R China (Fushun) Co. Ltd. and H&R China (Hong Kong) Co. Ltd. H&R Aktiengesellschaft acquired 51% of the shares and voting rights in H&R China Holding GmbH, into which the H&R Group's Chinese businesses have been bundled. As consideration, H&R Aktiengesellschaft granted 5,847,042 new shares. In addition H&R Aktiengesellschaft took over a liability due to taxes arising from the purchase of € 3.1 Mio. This led to a total amount of the transaction of € 43.2 Mio.

#### (5) Scope of consolidation and holdings

The consolidated financial statements of H&R AG include all domestic and foreign companies controlled by H&R AG. A control situation exists if H&R AG has the power to determine the financial and business policies of an enterprise so as to obtain benefits from its activities. H&R AG has direct or indirect control over the majority of the voting rights of its subsidiaries.

The table below shows the changes to H&R AG's consolidated group during the financial year:

#### CHANGE IN THE NUMBER OF CONSOLIDATED ENTERPRISES

H&R AG and consolidated companies	Domestic	Other countries	Total
31/12/2013	16	13	29
Additions	1	4	5
Disposals	-	-	-
31/12/2014	17	17	34

Effective September 25, 2014, as part of an increase in capital, the Hansen & Rosenthal Group transferred 51% of H&R China Holding GmbH to H&R Aktiengesellschaft as a contribution-in-kind in exchange for the issuance of new shares. Because H&R AG holds the majority of voting rights, it exercises control, so the number of companies to be consolidated increased. In addition to H&R

## Notes

(5) Scope of consolidation and holdings

The assets and liabilities on the date of the first-time consolidation are shown in the following table:

**FAIR VALUES ON THE ACQUISITION DATE**

IN MILLION €	25/9/2014
Intangible assets	30.1
Property, plant and equipment	56.9
Inventories	20.8
Trade receivables	15.3
Cash and cash equivalents	9.2
Other assets	2.5
Trade payables	12.6
Financial liabilities	37.4
Other liabilities	14.8
<b>Net assets</b>	<b>70.0</b>
Non-controlling interests (49%)	34.3
<b>Net assets acquired</b>	<b>35.7</b>
Consideration for acquisition of shares	43.2
<b>Difference</b>	<b>7.5</b>

The resulting positive difference of €7.5 million was recorded as goodwill. This amount is not tax-deductible and essentially represents the projected benefits from synergy effects, market expansion potential and employee know-how expected to result from the integration of the H&R China Group into H&R Aktiengesellschaft.

Pursuant to IFRS 3.19, H&R Aktiengesellschaft has chosen to measure non-controlling interests

(NCI) in the H&R China Group companies acquired at the NCIs' proportionate share of the net assets, which leads to a lower valuation.

€530 thousand of costs directly related to the merger were recorded as expenses during the period. The acquired receivables do not include any significant receivables that need to be classified as non-recoverable. As of 31 December 2014, the acquired companies had contributed neither to sales revenues nor to earnings. If the first-time consolidation of H&R China Group had been completed by 1 January 2014, sales revenues would have been €59.7 million higher and earnings would have been €3.7 million higher.

H&R AG holds shares in some companies via trust companies. These indirect shares are also fully consolidated whenever there is a control situation. The holdings can be seen in the ownership list. Although controlled by H&R AG, three companies were not included in the scope of consolidation, as they are of little importance for the net assets, financial position and results of operations of H&R AG.

The following disclosures concerning the holdings satisfy the requirements of Article 313 of the German Commercial Code (HGB):

**FULLY CONSOLIDATED SUBSIDIARIES**

Company name	Company headquarters	Segment	Holding % H&R AG
H&R Chemisch-Pharmazeutische Spezialitäten GmbH	Salzbergen, Germany	a	100
H&R Lube Blending GmbH	Salzbergen, Germany	a	100
H&R ChemPharm GmbH	Salzbergen, Germany	a	100
H&R LubeTrading GmbH	Salzbergen, Germany	a	100
H&R International GmbH	Hamburg, Germany	b	100
H&R Ölwerke Schindler GmbH	Hamburg, Germany	a	100
H&R InfoTech GmbH	Hamburg, Germany	d	100
H&R Benelux b.v.	Nuth, The Netherlands	b	100
H&R ChemPharm (UK) Ltd.	Tipton, Great Britain	b	100
H&R Czechia s.r.o.	Prague, Czech Republic	b	90
H&R ANZ Pty Ltd.	Victoria, Australia	b	100
H&R Singapore Pte. Ltd.	Singapore, Singapore	b	100
H&R Global Special Products Co. Ltd.	Bangkok, Thailand	b	100 <sup>1)</sup>
H&R Malaysia Sdn. Bhd.	Port Klang, Malaysia	b	100 <sup>1)</sup>
H&R ChemPharm (Thailand) Ltd.	Bangkok, Thailand	b	100
H&R WAX Malaysia Sdn. Bhd.	Batu Caves, Malaysia	b	100
H&R South Africa (Pty) Limited	Durban, South Africa	b	100
H&R South Africa GmbH	Hamburg, Germany	b	100
H&R South Africa Sales (Pty) Limited	Durban, South Africa	b	100

## Notes

## (5) Scope of consolidation and holdings

**FULLY CONSOLIDATED SUBSIDIARIES**

Company name	Company headquarters	Segment	Holding % H&R AG
H&R China Holding GmbH	Hamburg, Germany	b	51
H&R China (Hong Kong) Co., Ltd.	Hong Kong	b	51
H&R China (Ningbo) Co., Ltd.	Ningbo, China	b	51
H&R China (Fushun) Co., Ltd.	Fushun, China	b	51
H&R China (Daxie) Co., Ltd.	Daxie, China	b	51
H&R Grundstücksverwaltungs GmbH	Salzbergen, Germany	a	98.68
H&R Grundstücksverwaltungs-Beteiligungsgesellschaft mbH	Salzbergen, Germany	a	74.04
GAUDLITZ GmbH	Coburg, Germany	c	100
GAUDLITZ Precision Technology (Wuxi) Co. Ltd.	Wuxi, China	c	100
GAUDLITZ Precision s.r.o.	Dačice, Czech Republic	c	93.51
GAUDLITZ Grundstücksverwaltungs-Beteiligungsgesellschaft mbH	Coburg, Germany	c	100
H&R Group Services GmbH	Hamburg, Germany	d	100
SYTHEGRUND WASAGCHEMIE Grundstücksverwertungsges. Haltern mbH	Haltern, Germany	d	100
B.-H. Beteiligungs- und Handelsges. mbH	Salzbergen, Germany	d	100

**OTHER INVESTMENTS**

Company name	Company headquarters	Segment	Holding % H&R AG
<b>Joint Ventures</b>			
Westfalen Chemie GmbH & Co. KG	Salzbergen, Germany	a	50
Westfalen Chemie Verwaltungsgesellschaft mbH	Salzbergen, Germany	a	50
HRI IT-Service GmbH	Berlin, Germany	d	50
<b>Not Consolidated Subsidiaries</b>			
H&R India Sales Private Limited	Mumbai, India	b	99
WAFÄ Kunststofftechnik GmbH & Co. KG, i. K.	Augsburg, Germany		100
WAFÄ Kunststofftechnik Verwaltungs GmbH, i. K.	Augsburg, Germany		100
<b>Other Interests</b>			
SRS EcoTherm GmbH	Salzbergen, Germany		10
Surgic Tools GmbH	Coburg, Germany		10
Betreibergesellschaft Silbersee II Haltern am See mit beschränkter Haftung	Essen, Germany		8

Segments: a) Chem-Pharm Refining      c) Precision Plastics  
b) Chem-Pharm Distribution      d) Other activities

1) Including holdings held in trust: The holdings in the following companies are only indirectly held in trust:  
In H&R Global Special Products Co. Ltd., Bangkok, Thailand, H&R AG holds 49% of the shares via subsidiaries, 51% are managed for the Group by trust companies. H&R Global Special Products Co. Ltd. in turn holds 60.98% in H&R ChemPharm (Thailand) Ltd., Bangkok, Thailand. A further 38.98% are held by a subsidiary whose shares are wholly-owned by H&R AG. The remaining 0.04% are managed on behalf of the Group by trustees. The Group directly holds 30% of the shares in H&R Malaysia Sdn. Bhd., Port Klang, Malaysia. The remaining 70% are managed on behalf of the Group by trustees.

## Notes

Notes to the consolidated balance sheet

## Notes to the consolidated balance sheet

## (6) Cash and cash equivalents

€ THOUSAND	31/12/2014	31/12/2013
Cash on hand	30	12
Cash in banks	101,528	109,612
<b>Total</b>	<b>101,558</b>	<b>109,624</b>

## (7) Trade accounts receivables

€ THOUSAND	31/12/2014	31/12/2013
Trade accounts receivables (gross)	106,287	110,480
Impairment losses	-689	-755
<b>Total</b>	<b>105,598</b>	<b>109,725</b>

No trade accounts receivables (prior year: €0 thousand) were pledged as credit guarantees.

Receivables from related persons or companies are listed under note (42).

Within the scope of what is referred to as “true factoring agreements”, the H&R Group sells short-term Trade accounts receivables to credit institutes without recourse. H&R AG can freely decide whether and in what volume receivables will be sold. To the extent that any risks and opportunities related to these receivables remain at H&R AG, they continue to be recognised in the balance sheet. Late payment risk is the only risk remaining at H&R AG and is, moreover, of minor importance. As of 31 December 2014, receivables in the amount of €7.5 million (prior year: €7.4 million) were transferred, leading to a derecognition in total from the balance sheet.

## TRADE ACCOUNTS RECEIVABLES

€ THOUSAND	Carrying amount	Including: neither impaired nor overdue at the year-end date	Including: not impaired at the year-end date and overdue in the following aging periods					More than 360 days
			Less than 30 days	Between 31 and 60 days	Between 61 and 90 days	Between 91 and 180 days	Between 181 and 360 days	
31/12/2014	105,598	100,371	3,044	1,016	281	115	279	419
31/12/2013	109,725	101,229	5,639	1,445	459	353	570	30

With regard to the trade accounts receivables that are neither impaired nor overdue, there were no indications that the debtors would not honour their payment obligations.

In the Group, risk provisions in regard to trade accounts receivables based on individual write-downs can be summarised as follows:

## IMPAIRMENTS OF TRADE ACCOUNTS RECEIVABLE

€ THOUSAND	2014	2013
<b>Status as of 1/1</b>	<b>755</b>	<b>691</b>
Additions	211	238
Utilization	-329	-98
Redemptions	-	-41
Currency translation differences	52	-35
<b>Status as of 31/12</b>	<b>689</b>	<b>755</b>

Impaired trade account receivables are overdue with the following aging:

#### TRADE ACCOUNTS RECEIVABLE

€ THOUSAND	Less than 30 days	Between 31 and 60 days	Between 61 and 90 days	Between 91 and 180 days	Between 181 and 360 days	More than 360 days
31/12/2014	26	144	6	2	17	522
31/12/2013	116	26	199	40	4	370

#### (8) Inventories

€ THOUSAND	31/12/2014	31/12/2013
Raw, auxiliary, and production materials	54,270	47,997
Unfinished products	26,353	22,560
Finished products and products for sale	51,742	44,854
Advance payments on account on inventories	1,837	794
<b>Total</b>	<b>134,202</b>	<b>116,205</b>

Individual write-downs were performed with all inventories insofar as the proceeds that could foreseeably be realised from their sale were lower than their book value (Lower of Cost or Market principle). The net proceeds from disposal were

recognised as the foreseeable sales proceeds less any costs still arising up to the time of sale.

The fair value less sales expenses at which inventories are carried amounts €12,575 thousand (prior year: €6,595 thousand).

Pursuant to IAS 2.34, writedowns of the net disposal values were recognised as expenses in the reporting period in the amount of €2,044 thousand (prior year: €2,059 thousand). They concern the Chemical-Pharmaceutical Raw Materials Domestic and Precision Plastics Divisions.

No inventories (prior year: €0 thousand) were pledged as surety for liabilities.

#### (9) Other financial assets

€ THOUSAND	31/12/2014		31/12/2013	
	Total	Of which long-term	Total	Of which long-term
Loans and receivables	2,387	1,456	1,721	1,055
Receivable due from BP	1,730	1,730	942	942
Other securities	1,238	1,075	1,290	993
Other investments	1,055	1,055	1,055	1,055
Other financial assets	1,148	66	889	55
<b>Total</b>	<b>7,558</b>	<b>5,382</b>	<b>5,897</b>	<b>4,100</b>

The loans and receivables essentially comprise receivables from SRS Ecotherm as well as a loan to a joint venture enterprise.

Further to the takeover of the BP special business in 2004, mutual release agreements were made in regard to those retirees who were allocated either economically or contractually to one of the contractual partners, but who, for purposes of employment law, remained with the other partner. According to the overall contractual arrangements with BP, which included all release claims and liabilities, and taking into account the contractual parties' goal of achieving a total set-off of

**Notes**

Notes to the consolidated balance sheet

all payables and receivables, the claims and commitments were recognised based on the same legal background owing to the economic and legal substance of the business event and shown as a balance of €1,730 thousand pursuant to IAS 1.32.

The claims to compensation were as shown in the following table:

€ THOUSAND	2014	2013
Status as of 1/1	9,868	10,050
Interest income	353	380
Revaluation of the compensation claims	2,361	144
Claims paid	-688	-706
<b>Status as of 31/12</b>	<b>11,894</b>	<b>9,868</b>

The holdings essentially comprise the shares in SRS EcoTherm GmbH, Salzbergen, with a value of €1,050 thousand. The holdings are carried at acquisition cost, as these financial investments are not listed on any active market and therefore have no market price, and other valuation methods would not have led to reliable fair values. H&R AG is not intending to dispose of these holdings.

The remaining securities include in particular fund units of the Correnta Funds I and II. These securities are carried at their market value on the balance sheet date. Variances are shown in the other comprehensive income. This position also comprises the securities forming part of the current assets, which amounted to €163 thousand (prior year: €297 thousand) as of the balance sheet date.

Of the remaining financial assets, as of 31 December 2014 €6 thousand (prior year: €7 thousand) had specific valuation allowances.

**(10) Other assets**

€ THOUSAND	31/12/2014		31/12/2013	
	Total	of which long-term	Total	of which long-term
Reinsurance contracts	1,370	1,370	1,374	1,374
Other tax receivables	6,908	-	1,978	-
Prepaid expenses	815	15	745	71
Other assets	1,002	80	1,115	86
<b>Total</b>	<b>10,095</b>	<b>1,465</b>	<b>5,212</b>	<b>1,531</b>

The short-term accrual comprises prepaid amounts for which the pertinent expense is to be allocated to the following year. In the financial year under review, the position as shown essen-

tially represents insurance contributions, prepaid rents and accrued EDP maintenance remunerations. Other tax receivables mainly comprises vat-liabilities.

## (11) Property, plants &amp; equipment

## 2014 DEVELOPMENTS

€ THOUSAND	Land and Buildings	Technical equipment/machinery	Other facilities/office equipment	Advance payments and construction in progress	Total
<b>Acquisition and production costs</b>					
<b>Status as of 1/1/2014</b>	<b>48,510</b>	<b>352,771</b>	<b>19,054</b>	<b>7,718</b>	<b>428,053</b>
Changes in scope of consolidation	37,825	17,011	760	1,286	56,882
Additions	73	11,219	887	11,192	23,371
Disposals	-557	-672	-262	-1,057	-2,548
Currency conversion	1,216	1,835	159	46	3,256
Transfers	323	3,394	899	-5,500	-884
<b>Status as of 31/12/2014</b>	<b>87,390</b>	<b>385,558</b>	<b>21,497</b>	<b>13,685</b>	<b>508,130</b>
<b>Cumulative depreciation</b>					
<b>Status as of 1/1/2014</b>	<b>25,249</b>	<b>188,103</b>	<b>15,851</b>	<b>944</b>	<b>230,147</b>
Scheduled depreciation	2,112	19,498	1,462	-	23,072
Impairment losses	-	-	-	69	69
Disposals	-	-655	-179	-1,010	-1,844
Currency conversion	157	1,121	128	-	1,406
<b>Status as of 31/12/2014</b>	<b>27,518</b>	<b>208,067</b>	<b>17,262</b>	<b>3</b>	<b>252,850</b>
<b>Book value</b>					
<b>Status as of 31/12/2014</b>	<b>59,872</b>	<b>177,491</b>	<b>4,235</b>	<b>13,682</b>	<b>255,280</b>
<b>Status as of 31/12/2013</b>	<b>23,261</b>	<b>164,668</b>	<b>3,203</b>	<b>6,774</b>	<b>197,906</b>

## 2013 DEVELOPMENTS

€ THOUSAND	Land and Buildings	Technical equipment/machinery	Other facilities/office equipment	Advance payments and construction in progress	Total
<b>Acquisition/manufacturing costs</b>					
<b>Status as of 1/1/2013</b>	<b>48,693</b>	<b>340,114</b>	<b>19,893</b>	<b>12,895</b>	<b>421,595</b>
Additions	359	8,573	228	3,800	12,960
Disposals	-32	-2,353	-998	-13	-3,396
Currency conversion	-791	-2,089	-185	-41	-3,106
Transfers	281	8,526	116	-8,923	-
<b>Status as of 31/12/2013</b>	<b>48,510</b>	<b>352,771</b>	<b>19,054</b>	<b>7,718</b>	<b>428,053</b>
<b>Cumulative depreciation</b>					
<b>Status as of 1/1/2012</b>	<b>23,759</b>	<b>162,375</b>	<b>15,402</b>	<b>942</b>	<b>202,478</b>
Scheduled depreciation	1,730	20,233	1,543	2	23,508
Impairment losses	-	9,000	-	-	9,000
Disposals	-26	-2,249	-954	-	-3,229
Currency conversion	-214	-1,256	-140	-	-1,610
<b>Status as of 31/12/2013</b>	<b>25,249</b>	<b>188,103</b>	<b>15,851</b>	<b>944</b>	<b>230,147</b>
<b>Book value</b>					
<b>Status as of 31/12/2013</b>	<b>23,261</b>	<b>164,668</b>	<b>3,203</b>	<b>6,774</b>	<b>197,906</b>
<b>Status as of 31/12/2012</b>	<b>24,934</b>	<b>177,739</b>	<b>4,491</b>	<b>11,953</b>	<b>219,117</b>

Land and buildings are essentially production sites of the Group companies and the technical plant and machinery are production facilities. A plot of land belonging to the Group subsidiary

SYTHENGRUND has an underground quartz sand mine, which according to geological appraisals would comprise some 13.5 million tons. The additions to assets represented by facilities in 2014

## Notes

Notes to the consolidated balance sheet

refer primarily to the refinery sites in Salzbergen and Hamburg. In Salzbergen, investments were made in the capacity expansion of the hydration refining processes. At the Hamburg site, the additions in essential investments led to an increase in energy efficiency. Moreover, expenditures made at both sites in connection with planned shut-downs were capitalised.

The H&R Group has entered into a number of financing and operating lease agreements for technical equipment, operating and office equipment: as well as intangible assets. The financial leases comprise essentially an agreement that meets the requirements of IFRIC 4 and relates to the supply of energy as well as of cooling and boiler feed water. The term of the Agreement is of approximately 20 years and will end on 30 June 2023.

Tangible fixed assets used under finance leases are reported under property, plant and equipment with a carrying amount of €16,659 thousand (previous year: €8,757 thousand). This amount is further broken down into technical equipment and machinery, with a carrying amount of €8,604 thousand (previous year: €8,019 thousand) and land and buildings, with a carrying amount of €8,055 thousand (previous year: €0). As of the balance-sheet date, the acquisition costs of these fixed assets totaled €28,365 thousand (previous year: €18,786 thousand).

The finance leasing agreements involve the lease payments listed below that will become due in the following periods. The variable leasing instalments were carried forward based on the last effective interest rate:

€ THOUSAND	Up to 1 year		1 to 5 years		Longer than 5 years	
	31/12/2014	31/12/2013	31/12/2014	31/12/2013	31/12/2014	31/12/2013
Minimum leasing instalments	634	659	373	882	-	-
Future financing costs from financial leases	39	64	8	35	-	-
Cash value of the financial lease liabilities	595	595	365	847	-	-

Most of these payments relate to an agreement that meets the requirements for financial leases and concerns the supply of energy as well as of cooling and boiler feed water.

None of the assets underlying the financial leases may be disposed of during the term of their respective leases.

In addition to the finance leases, other leasing and/or rental agreements were also entered into which must be classified as operating leases based on their contents, as the property constituting the subject matter of the lease or rental agreement is to be allocated to the lessor or landlord. This involves in particular land and buildings, hardware, vehicles, forklift trucks, office machines and tank railcars. As a rule, the terms of these leases range between two and five years. The agreements generally terminate automatically at the expiry of their term, although in some cases there are extension options.



Future minimum leasing payments based on in future periods as follows:  
non-cancellable operating leases will become due

€ THOUSAND	Up to 1 year		1 to 5 years		Longer than 5 years		Total	
	31/12/2014	31/12/2013	31/12/2014	31/12/2013	31/12/2014	31/12/2013	31/12/2014	31/12/2013
Land/Buildings	1,284	1,390	4,428	4,505	21,600	22,695	27,312	28,590
Technical plant and equipment	1,792	1,499	1,471	2,173	–	–	3,263	3,672
Office and operating equipment	1,696	1,807	1,904	3,077	–	–	3,600	4,844
<b>Total</b>	<b>4,772</b>	<b>4,696</b>	<b>7,803</b>	<b>9,755</b>	<b>21,600</b>	<b>22,695</b>	<b>34,175</b>	<b>37,146</b>

## (12) Goodwill and other intangible assets

The intangible assets developed as follows during financial year 2014:

### 2014 DEVELOPMENTS

€ THOUSAND	Goodwill	Other intangible assets					Total	Total
		Distribution rights and similar laws	Software	Licences	Patents/copy-rights	Other rights		
<b>Acquisition/manufacturing costs</b>								
<b>Status as of 1/1/2014</b>	<b>47,491</b>	<b>1,348</b>	<b>9,876</b>	<b>3,602</b>	<b>238</b>	<b>223</b>	<b>15,287</b>	<b>62,778</b>
Currency conversion	246	426	15	39	350	-107	830	1,076
Changes in scope of consolidation	–	16,832	–	–	13,277	–	30,109	30,109
Additions	7,530	17	111	69	–	138	335	7,865
Disposals	–	–	–	-1	–	–	-108	-108
Transfers	–	–	19	884	–	-19	884	884
<b>Status as of 31/12/2014</b>	<b>55,267</b>	<b>18,623</b>	<b>10,021</b>	<b>4,593</b>	<b>13,865</b>	<b>235</b>	<b>47,337</b>	<b>102,604</b>
<b>Cumulative depreciation</b>								
<b>Status as of 1/1/2014</b>	<b>15,359</b>	<b>1,192</b>	<b>8,243</b>	<b>2,155</b>	<b>238</b>	<b>38</b>	<b>11,866</b>	<b>27,225</b>
Currency conversion	–	23	14	7	42	–	86	86
Scheduled depreciations	–	363	597	725	313	8	2,006	2,006
Impairment losses	–	75	380	–	–	37	492	492
Disposals	–	–	–	–	–	–	–	–
<b>Status as of 31/12/2014</b>	<b>15,359</b>	<b>1,653</b>	<b>9,236</b>	<b>2,887</b>	<b>593</b>	<b>83</b>	<b>14,452</b>	<b>29,811</b>
<b>Book value</b>								
<b>Status as of 31/12/2014</b>	<b>39,908</b>	<b>16,970</b>	<b>785</b>	<b>1,706</b>	<b>13,272</b>	<b>152</b>	<b>32,885</b>	<b>72,793</b>
<b>Status as of 31/12/2013</b>	<b>32,132</b>	<b>156</b>	<b>1,633</b>	<b>1,447</b>	<b>–</b>	<b>185</b>	<b>3,421</b>	<b>35,553</b>

## Notes

Notes to the consolidated balance sheet

## 2013 DEVELOPMENTS

€ THOUSAND	Goodwill	Conces- sions, patents etc.	Software	Licences/ franchises	Other intangible assets			Total	Total
					Patents/ copy- rights	Advances to suppli- ers/ Items under develop- ment	Total		
<b>Acquisition/manufacturing costs</b>									
<b>Status as of 1/1/2013</b>	<b>47,700</b>	<b>1,319</b>	<b>9,825</b>	<b>3,629</b>	<b>267</b>	<b>177</b>	<b>15,217</b>	<b>62,917</b>	
Currency conversion	-209	-	-5	-58	-29	-	-92	301	
Additions	-	54	56	31	-	46	187	187	
Disposals	-	-25	-	-	-	-	-25	-25	
<b>Status as of 31/12/2013</b>	<b>47,491</b>	<b>1,348</b>	<b>9,876</b>	<b>3,602</b>	<b>238</b>	<b>223</b>	<b>15,287</b>	<b>62,778</b>	
<b>Cumulative depreciation</b>									
<b>Status as of 1/1/2013</b>	<b>12,282</b>	<b>1,085</b>	<b>7,397</b>	<b>1,985</b>	<b>267</b>	<b>30</b>	<b>10,764</b>	<b>23,046</b>	
Currency conversion	-	-	-4	-1	-29	-	-34	-34	
Scheduled depreciations	-	120	850	171	-	8	1,149	1,149	
Impairment losses	3,077	-	-	-	-	-	-	3,077	
Disposals	-	-13	-	-	-	-	-13	-13	
<b>Status as of 31/12/2013</b>	<b>15,359</b>	<b>1,192</b>	<b>8,243</b>	<b>2,155</b>	<b>238</b>	<b>38</b>	<b>11,866</b>	<b>27,225</b>	
<b>Book value</b>									
<b>Status as of 31/12/2013</b>	<b>32,132</b>	<b>156</b>	<b>1,633</b>	<b>1,447</b>	<b>-</b>	<b>185</b>	<b>3,421</b>	<b>35,553</b>	
<b>Status as of 31/12/2012</b>	<b>35,418</b>	<b>234</b>	<b>2,428</b>	<b>1,644</b>	<b>-</b>	<b>147</b>	<b>4,453</b>	<b>39,871</b>	

During 2014, €37,639 thousand of intangible assets were added as part of the takeover of the Hansen & Rosenthal Group's Chinese businesses. This amount included €13,277 thousand for technology and research and development, €16,832 thousand for acquired customer relationships and

€7,530 thousand for goodwill. The goodwill was allocated to the CGU H&R China which is part of the segment ChemPharm Sales.

The carrying value of goodwill is composed as follows:

€ THOUSAND		31/12/2014	31/12/2012
<b>Reporting segment</b>	<b>Cash Generating Unit</b>		
ChemPharm Refining	CGU Salzbergen	16,738	16,738
ChemPharm Sales	CGU H&R China	7,720	-
ChemPharm Sales	CGU H&R ChemPharm (UK)	282	282
ChemPharm Sales	CGU Asia	414	388
ChemPharm Sales	CGU Australia	790	760
ChemPharm Sales	CGU South Africa	13,964	13,964
<b>Total</b>		<b>39,908</b>	<b>32,132</b>

In performing the impairment test on the CGU, Management must make certain future-oriented valuation assumptions. Basically, these valuation assumptions, which are made in the face of uncertainty, may differ from actual later values, which can cause the recoverable amount to drop below the respective carrying amount of the CGU, thereby triggering recognition of an impairment loss. A sensitivity analysis was performed on the cash-generating units to which goodwill has

been allocated; the sensitivity analysis involved reducing future cash flows by 10%, increasing the weighted cost of capital by 10% and lowering the growth rate by one percentage point. With the exception of the South African CGU, this did not result in an impairment to any CGU. In the case of the South African CGU, a 7.9% increase in the weighted average cost of capital or a 7.9% reduction in cash flow would cause the recoverable amount to be equal to the CGU's carrying value.

The other intangible assets are essentially production and application software as well as production, control and process flow licenses. Moreover, expenses arising in connection with the registration of products pursuant to the EU Chemicals Regulation (REACH) were also capitalized under other intangible assets. The additions in financial year 2014 primarily refer to the acquisition of new software licenses. The unscheduled depreciation charge of €492 thousand relates to CGU Gaudlitz GmbH, which is part of the Plastics Division. This impairment loss is attributable to weaker expectations for expected future cash flow contributions by the CGU, meaning that the CGU's recoverable amount is below the carrying amount.

### (13) Shares in at-equity valued holdings

The reported shares in at-equity valued holdings concern, partly, the 50% share in the joint venture Westfalen Chemie GmbH & Co. KG as well as the related general partner Westfalen Chemie Verwaltungsgesellschaft mbH. Westfalen operates a hydrogen production and bottling facility at the Salzbergen site, from which the Salzbergen Refinery obtains hydrogen for its own production. Furthermore, financial year 2012 saw the creation of the joint venture HRI IT Service GmbH, Berlin, in which H&R AG holds 50% of the shares via its subsidiary H&R InfoTech GmbH.

Data and informations of at-equity valued shares in companies included in the H&R Group Financial Statements are in accordance with the Group accounting policy. The Financial year of the at-equity companies corresponds to the calendar year which is applicable for the H&R Group. The following statement comprises the aggregated Financial informations of the at-equity companies which are not material pursuant to IFRS 12:

€ THOUSAND	31/12/2014	31/12/2013
<b>Assets</b>		
Long-term assets	1,348	1,368
Current assets	1,886	1,730
<b>Debts</b>		
Non-current liabilities	364	364
Current liabilities	2,670	2,680
<b>Net assets</b>	<b>200</b>	<b>54</b>
Revenue	11,296	11,196
Costs	-11,048	-10,458
Earnings after income taxes	248	738
Other comprehensive income	-	-
<b>Total comprehensive income</b>	<b>248</b>	<b>738</b>

H&R AG holds 50% of these amounts leading to a change in the current value of shares in at-equity valued holdings as follows:

€ THOUSAND	2014	2013
<b>Book values 1/1</b>	<b>923</b>	<b>842</b>
Partial result	124	369
Distribution	-284	-288
<b>Book values 31/12</b>	<b>763</b>	<b>923</b>

### (14) Liabilities to banks

Liabilities to banks include the following items:

€ THOUSAND	Book value 31/12/2014	Residual term up to one year	Residual term 2016 to 2018	From 2019 onwards
Borrower's note loan	116,000	-	116,000	-
Other loans	92,069	52,018	33,801	6,250
<b>Total</b>	<b>208,069</b>	<b>52,018</b>	<b>149,801</b>	<b>6,250</b>
Of which secured	13,002	-	-	-

€ THOUSAND	Book value 31/12/2013	Residual term up to one year	Residual term 2015 to 2017	From 2018 onwards
Borrower's note loan	118,528	-	118,528	-
Other loans	63,013	13,312	35,951	13,750
<b>Total</b>	<b>181,541</b>	<b>13,312</b>	<b>154,479</b>	<b>13,750</b>
Of which secured	13,750	-	-	-

**Notes**

Notes to the consolidated balance sheet

**BORROWER'S NOTE LOANS.** Each borrower's note loan consists of two tranches with a maturity of from five to seven years. A tranche of €42.0 million with a five-year term and another of €35.0 million with a seven-year term are subject to variable interest rates at six-month EURIBOR plus a credit margin, while the remaining tranches were arranged at fixed interest rates of 3.64% to 4.24%. Variable interest tranches totaling €80.0 million were hedged by means of an interest-rate swap to cover interest-rate fluctuation risks. The conditions and termination rights are dependent on compliance with certain stipulations and financial ratios such as the debt/equity ratio and the equity ratio (covenants). In the event of a change of control, the party extending the borrower's note loan is entitled to terminate the agreements.

**SYNDICATED LOAN.** On 7 February 2014, as part of the Waiver and Amendment Procedure begun in December of 2013, H&R AG's syndicated loan was amended and restructured. In the process, the syndicated revolving loan for €90 million was transformed into a bilateral revolving loan and letter of credit facility in the amount of €72,5 million with the option of being increased to €90 million. The increase option was valid until 30 September 2014 and was not exercised by H&R AG. As at 31. December 2014, the letter of credit facilities were used by € 25,5 Mio.

The availability and conditions are linked to certain ratios (financial covenants). In the event of a breach of a covenant, the syndicate banks are entitled to terminate the syndicated loan. The syndicated loan is subject to a variable interest rate (EURIBOR + margin). The margin percent-

age is dependent on certain financial covenants (Net Debt/EBITDA). The adjustment always takes place after the filing of the quarterly and/or annual reports. The syndicated loan was only utilized to a minor extent in financial year 2014.

**OTHER LOANS.** The other loans were obtained subject to fixed or variable interest rates based on EURIBOR. The interest rates on the fixed-rate loans range from 3.50% to 6.90%. financial covenants. Financial covenants such as the debt/equity ratio and the equity ratio are included in the agreements for the borrower's note loans and the syndicated loans as well as for bilateral loans. For those banks whose agreements require the debt/equity ratio to be tested on a quarterly basis, we agreed to adjust the "Debt/Equity Ratio" financial covenant in the syndicated and bilateral loans to 3.5, and to 3.75 for the quarters up to 31 March 2015. The financial covenants were fully met both at the balance sheet date and also during the course of the year.

**COLLATERAL.** Fixed assets with a value of €15 million were pledged as collateral for loans from the KfW [Kreditanstalt für Wiederaufbau/ Reconstruction Credit Corporation] environmental program originally amounting to €20 million.

No collateral was pledged for either the syndicated loan or for the borrower's note loan.

**(15) Trade payables**

Trade payables have a term of up to one year and are usually collateralised by means of retention of title.

## (16) Other provisions

€ THOUSAND	HR provisions	Environmental protection	Trade-related commitments	Miscellaneous provisions	Total
<b>Status as of 31/12/2013</b>	<b>8,086</b>	<b>1,051</b>	<b>867</b>	<b>2,394</b>	<b>12,398</b>
of which long-term	3,497	1,051	–	–	4,548
Changes in scope of consolidation	97	–	1,483	1,694	3,274
Interest compounding	143	–	–	–	143
Currency translation differences	109	–	31	55	195
Utilization	-4,546	–	-345	-3,622	-8,513
Reversal	-662	-326	-416	-99	-1,503
Additions	6,011	–	541	1,022	7,574
<b>Status as of 31/12/2014</b>	<b>9,238</b>	<b>725</b>	<b>2,161</b>	<b>1,444</b>	<b>13,568</b>
of which long-term	3,545	725	–	–	4,270

Cash outflows totalling €9,298 thousand are expected in relation to the short-term portion of the provisions capitalised as of 31 December 2014 in the following year. The remaining amount of 4,270 thousand will only cause cash outflows starting in 2016.

### (16.1) Human Resources provisions

The short-term HR provisions primarily concern directors' fees, profit sharing, performance bonuses, deferred leave, flexi-time credits as well as professional association contributions.

The long-term HR provisions consist of early retirement pensions and service anniversaries.

### (16.2) Environmental protection

Subsoil contamination with hazardous materials resulting from the production of ammunition (grenades) under the supervision of the armed forces during the two World Wars and from the decommissioning of military explosives had already been discovered some time ago on a piece of land belonging to a Group company that had been used by third parties to produce such explosive materials. The affected soil had already been disposed of some years ago. The trend in the hazardous materials concentration in the ground and surface water is regularly measured and monitored in conjunction with the relevant authorities.

The explosives business was sold in 2007; however, the land was not also transferred to the buyer, but, rather, was leased to the explosives company, which continued its activities on the site.

SYTHENGRUND GmbH had various assessments carried out about the hazardous materials situation. These assessments revealed that the pollutants plume extending beyond the site borders could not be removed using current technology. The company is therefore focusing its ongoing measures on monitoring and securing the pollutants and supporting research projects into developing more advanced chemical/physical treatment methods. The planned sand removal project has no influence on the grandfathered environmental liabilities situation, as it would not change the spreading direction of the pollutants in the groundwater.

### (16.3) Trade-related commitments

Provisions for trade-related commitments comprise provisions for complaints, rebates, discounts and price-reductions.

### (16.4) Miscellaneous provisions

The remaining provisions primarily comprise provisions for waste disposal and other commitments.

## Notes

Notes to the consolidated balance sheet

## (17) Other financial liabilities

€ THOUSAND	31/12/2014		31/12/2013	
	Total	Of which long-term	Total	Of which long-term
Lease liabilities	960	365	1,442	847
Loan liabilities	2,960	–	–	–
Liabilities arising from derivatives	6,653	4,345	6,815	4,676
Liabilities from acquisitions	3,080	–	–	–
Other financial liabilities	3,872	2	1,904	10
<b>Total</b>	<b>17,525</b>	<b>4,712</b>	<b>10,161</b>	<b>5,533</b>

The leasing liabilities result from financial leases. Further information concerning finance leases can be found in note (11).

The liabilities from acquisitions result from the purchase of the chinese activities and are tax liabilities arising from that transaction.

The liabilities originating from derivatives result from transactions intended to hedge interest rate risks. Further details about derivatives can be found in note (37).

## (18) Other liabilities

€ THOUSAND	31/12/2014		31/12/2013	
	Total	Of which long-term	Total	Of which long-term
Tax liabilities	3,131	–	11,577	–
Payments received	3,288	–	–	–
Prepaid expenses	2,775	79	123	101
Other liabilities	833	–	302	–
<b>Total</b>	<b>10,027</b>	<b>79</b>	<b>12,002</b>	<b>101</b>

The tax liabilities primarily concern the current VAT and payroll tax liabilities as well as import VAT still due.

The accruals and deferrals include an investment subsidy received by H&R Lube Blending GmbH from the German Federal Land of Lower Saxony. The subsidy, which had been applied for in 1996, was approved in 1998 and constitutes 15% of the investment sum. Recognition takes place on a pro rata temporis basis in accordance with the respective useful life of the subsidised assets.

## (19) Pension provisions

Operating retirement provisions in the Group are not only contribution-based but also performance-based.

In the case of the pensions systems (defined contribution plans) the Group pays contributions to state or private pension schemes on the basis of legal or contractual provisions, or on a voluntary basis. Following payment of the contributions, the Group's obligations in this area are fulfilled. Defined contribution pension plans exist particularly in the international companies of the Chemical-Pharmaceutical Raw Materials Division.

All other retirement provisions are performance-based and result from various take-overs of business areas and activities. These benefits apply exclusively to Germany based companies. All pension plans of the H&R Group are closed or frozen, so that H&R AG is only exposed to risks arising out of pension and salary trends as well as from demographic changes based on existing

commitments. With the exception of reinsurance for the pension of a former Director, there are no plan assets, so that there is currently no strategy for the equalisation of risks arising out of either assets or liabilities.

The present H&R AG was formed from the merger of Schmierstoffraffinerie Salzbergen GmbH (SRS GmbH) and H&R AG in 2001. Because of the works agreement on 7 October 1986, all employees taken on by SRS GmbH from Wintershall have a right to company pension benefits in accordance with the Wintershall pension agreement dated 1 January 1987. The works agreement of 9 March 1994 terminated the works agreement of 7 October 1986 effective 30 June 1994, and thereby enacted the pension agreement for the new arrivals. The level of benefits agreed depends essentially on the length of service and the last salary drawn. After the termination of the works agreement of 7 October 1986, the entitlements earned were frozen. The pension entitlements of some pensioners are based on the older Wintershall pension charter.

All employees at H&R AG have a right to a company pension in accordance with the pension agreement in the version dated 1 January 1986, last amended by the works agreement of 4 June 1998. For those drawing pensions, their rights in some cases are based on earlier versions of the pension agreement. The level of the pension depends on the number of pensionable years of service and the pensionable salary in the last year before leaving the company. Individual employees receive so-called contractual pensions due to individual contractual commitments. The requirements and calculation of benefits differ in individual agreements.

In accordance with the pension agreement at GAUDLITZ GmbH in the version of 18 December 1978, all employees who joined the company by 10 June 1978 and whose contracts of employment had not been terminated had the right to a company pension. The level of the pension depends on the number of pensionable years of service and the pensionable salary in 1978. For those drawing pensions, in some cases their rights are based on earlier versions of the pension agreement.

At SYTHENGRUND Wasagchemie Grundstücksverwertungsgesellschaft Haltern mbH, there is a pension provision dating from 1 January 1986 in the version of the works agreement of 4 June 1998 of Chemie Sythen GmbH. The level of the pensions depends on the number of pension qualifying years of service and on the pension qualifying earnings. The pension scheme was closed in 1992 for people joining the company after 31 July 1991.

Pension obligations for a total of 183 employees were transferred to H&R Ölwerke Schindler effective 2 January 2004 with the takeover of BP's special product activities. Due to various mergers and takeovers, there are a total of 13 different sets of rules and addenda that may apply to these 183 employees. The basic principles are set forth in the following pension-related directives, statutes, regulations, schemes etc.:

- Pension regulations for employees of Aral AG on non-union rates dated 24 June 1991
- Pension scheme for employees of Aral AG on union rates dated 15 October 1985
- Aral AG pension regulations 1999
- Pension rules dated 1 January 1980 pursuant to the Central Works Agreement dated 30 November 1979
- Additional pension for shift work in accordance with Letter f of the Pension Regulations of 1 January 1980 pursuant to the Central Works Agreement dated 30 November 1979
- 1988 Pension Regulations based on the Central Works Agreement dated 2 December 1987
- Pension Regulations dated 1 January 1988, Section 13 (Articles 40-46) on the basis of the Central Works Agreement dated 2 December 1987
- Pension plan of Burmah Oil (Germany) GmbH dated 1 January 1992
- Salary conversion in accordance with the ARAL pension regulation model 1999
- Transitional payment regulations Raab Karcher dated 1 March 1989
- Central Works Agreement dated 1 February 1993 (1975 Pension Plan)
- Central Works Agreement dated 1 January 1993 (1986 Pension Plan)
- Central Works Agreement dated 1 February 1993 (1990 Pension Plan)

## Notes

Notes to the consolidated balance sheet

The pension amount in the above-mentioned plans is determined based on the pension qualifying years of service and on the pensionable monthly remuneration taking into account the minimum qualifying minimum number of years of service.

H&R Ölwerke Schindler has not only assumed pension obligations for employees of the company with entitlements (so-called Group 1) but has also agreed an exemption obligation for some former employees of BP Lubes Services GmbH (pensioners and employees who left the company, so-called Group 3). The company is entitled to reimbursement from BP of the sum posted for the commitments towards the aforementioned categories of qualified individuals [see also note (9)].

The scope of obligations of H&R Ölwerke Schindler GmbH was taken into consideration as of 31 December 2014 for the individual groups as follows:

€ THOUSAND	31/12/2014	31/12/2013
Group 1	44,956	31,908
Group 3	11,894	9,868

A further category (so-called Group 2) comprises employees of BP who were not taken on by H&R Ölwerke Schindler. For this group of people, H&R Ölwerke Schindler has agreed to reimburse bp for the relevant pension obligations which remain with bp, for an amount of €10,164 thousand. These obligations were netted off in accordance with IAS 1.33 against a receivable from bp from a reimbursement claim for pension obligations assumed amounting to €11,894 thousand, which also arose as part of the takeover of the specialty products business [see note (9)]. The balancing receivable of €1,730 thousand is shown under receivables from BP in other long-term assets.

The development of the liability due to defined benefit plan can be described as follows:

€ THOUSAND	2014	2013
<b>Status as of 1/1</b>	64,376	63,332
Current service cost	716	719
Interest expenses	2,325	2,408
Revaluations	19,485	1,176
Including due to changes in financial assumptions	20,078	1,772
Including due to experiential adjustments	-593	-596
Including due to changes in demographic assumptions	-	-
Payments made	-3,254	-3,259
<b>Status as of 31/12</b>	<b>83,648</b>	<b>64,376</b>

The plan assets of H&R AG are related to a reinsurance policy for a guaranteed pension of a former member of the Board; this policy is recognised at fair value. Planned assets are not listed on any active market. No risks result for H&R AG from these plan assets. Future expected annual contributions of H&R AG to this reinsurance policy amount to €249 thousand and will be due in 2016 for the last time.

The fair value of plan assets developed as follows:

€ THOUSAND	2014	2013
<b>Status as of 1/1</b>	<b>810</b>	<b>555</b>
Interest income	28	22
Revaluations	-6	-16
Contributions to plan	249	249
<b>Status as of 31/12</b>	<b>1,081</b>	<b>810</b>

The development in the carrying amount of the net debt related to benefit oriented pension plans can be described as follows:



€ THOUSAND	2014	2013
<b>Status as of 1/1</b>	<b>63,566</b>	<b>62,777</b>
Current service cost	716	719
Interest expenses	2,297	2,386
Payments made	-3,254	-3,259
Employee contributions to the plan	-249	-249
Revaluations	19,490	1,192
Including return on plan assets	6	16
Including due to changes in financial assumptions	20,077	1,772
Including due to experiential adjustments	-593	-596
Including due to changes in demographic assumptions	-	-
<b>Status as of 31/12</b>	<b>82,566</b>	<b>63,566</b>

The following valuation parameters were used to determine the pension obligations:

	31/12/2014	31/12/2013
Interest rate	2.0%	3.7%
Salary trends	0.0%–4.0%	0.0%–4.0%
Pension trends	0.0%–2.0%	0.0%–2.0%
Retirement age	60/61/63/65	60/61/63/65

The likelihood of leaving is based on the 2005g Heubeck guideline tables. An age-dependent staff turnover probability has been built into the pension provision for employees of H&R Ölwerke Schindler for which tables drawn up by internal experts have been used. By not taking the likelihood of fluctuations into account, the assumption is made by way of simplification that no employee will leave the company before the non-forfeitability deadlines are met and that thereafter the non-forfeitable right to a pension will be exactly financed by the existing provision in each case.

There were no plan changes, curtailments or settlements in financial year 2014.

Payments totalling €3,820 thousand (previous year: €3,814 thousand) are anticipated for this financial year. The duration of the benefit obligations is, on average, 15.9 years.

To the extent that the parameters in the following table should change as stated, this would result in pension obligation changes as shown below.

#### SENSITIVITY OF BENEFIT OBLIGATIONS

	Change in indicators in %		Change in obligation on increasing indicators in € thousand		Change in obligation on decreasing indicators in € thousand	
	2014	2013	2014	2013	2014	2013
Change in discount rate	0.50	0.50	-6,352	-4,519	6,932	5,044
Change in future salary increases	0.50	0.50	1,163	483	-	-
Change in future pension adjustments	0.25	0.25	1,633	1,439	-	-

The above sensitivity analyses are based on the assumption of a change in one parameter while all other parameters remain constant. These are individual scenarios from a broad spectrum of possibilities, so that the actual trend in the commitment will most certainly deviate from these forecasts. In addition, it is unlikely that only one parameter will change, but, rather, in actual fact an interaction of parameter changes can be ex-

pected. The sensitivities were calculated with the same method as the recognition of the benefit obligations in the balance sheet. The methods were not changed as compared to the prior year.

All pension plans within the H&R Group are closed, so that no new employees can gain access to them. Only H&R Ölwerke Schindler GmbH still has active employees with a pension claim. For

**Notes**

Notes to the consolidated balance sheet

this reason, neither effects from a sinking pension level nor from a downward salary trend are to be expected, so that no sensitivity analysis was undertaken in this regard.

**(20) Subscribed capital**

During the financial year, subscribed capital was increased through the issuance of 5,847,042 ordinary shares; as of the balance sheet, it totaled to €91,573 thousand, divided into 35,820,154 ordinary shares (previous year: 29,973,112 ordinary shares). The subscribed capital was fully paid in. Each share provides one voting right.

**APPROVED CAPITAL.** By a decision of the Annual Shareholders' Meeting of 31 May 2011, the Executive Board is entitled, subject to approval by the Supervisory Board, to increase issued capital through one or more issues of ordinary bearer shares without face value in return for cash. Said issuance(s) may occur any time before 30 May 2016, may total up to €1 million in volume (2011 Approved Capital), and must be issued for the purpose of distributing employee shares to the personnel of the Group and/or its affiliated companies. The shareholders' subscription rights are barred.

The Executive Board is authorized, with the approval of the Supervisory Board, to increase the company's share capital by 12 September 2019 by a maximum of €22.4 million. The issue may take place in one or more tranches of ordinary bearer shares without face value in return for cash and/or contributions-in-kind. Furthermore, with the Supervisory Board's approval, the Executive Board may decide on the conditions of the share issue (2014 Approved Capital). In principle, the shareholders are to be granted subscription rights. The latest amendment (restriction on the issue of ordinary shares) was entered in the Commercial Register on 25 September 2014.

**AUTHORIZATION TO ACQUIRE TREASURY SHARES.** The company's Annual Shareholders' Meeting on 27 May 2010 authorized the purchase of the company's own shares up to a total of 10 % of the current share capital in the period up to 26 May 2015. Purchasing treasury shares with the intention of trading them is not permitted. The consideration for the purchase of these shares must not be 10 % higher or lower than the average share price (closing price of H&R AG shares on the Frankfurt Stock Exchange) on the last five days of trading before the shares are purchased. The company did not purchase any of its own shares either in 2014 or in the previous year.

**(21) Additional paid-in capital**

Additional paid-in capital includes the amounts by which the proceeds from the issuance of preferred and ordinary shares exceed their face value. Due to the issuance of ordinary shares in financial year 2014, additional paid-in capital increased by €24,730 thousand, from €18,599 thousand to €43,329 thousand.

**(22) Revaluation reserves**

Revaluation reserves contain reserves for the marking-to-market of securities in the amount of €265 thousand (previous year: €131 thousand) and reserves for cash-flow hedges totaling €-2,797 thousand (previous year: €-3,747 thousand). Expenses after tax reported under other income include reserves for cash-flow hedges of €950 thousand (previous year: €993 thousand) and income of €134 thousand (previous year: expenses of €8 thousand) on reserves for the marking-to-market of securities.

**(23) Retained earnings**

Retained earnings incl. annual Group deficit/surplus amounted to €73,773 thousand as of the reporting date (previous year: €102,833 thousand). Most of this amount consists of cumulative retained earnings of €95,048 thousand (previous year: €110,450 thousand).

At the Annual Shareholders' Meeting on 13 May 2014, it was decided not to distribute any dividends from H&R AG's annual net income as determined in accordance with the German Commercial Code (HGB). The Executive Board and the Supervisory Board will submit a proposal to the Annual Shareholders' Meeting of 19 May 2015 not to distribute dividends for financial year 2014 as the annual financial statements prepared in accordance with the HGB do not show any distributable profits. This proposal is subject to approval by the shareholders at the Annual Shareholders' Meeting.

#### (24) Non-controlling interests

Non-controlling interests include shares of earnings and capital held by shareholders outside the Group; during the year under review, these changed as follows.

€ THOUSAND	2014	2013
<b>Status as of 1/1</b>	<b>-79</b>	<b>-48</b>
Addition from contribution of Chinese businesses	34,261	–
Addition from capital increase	4,974	–
Currency translation differences	852	3
Dividends	–	-26
Proportionate shares of net income or loss	-206	-8
<b>Status as of 31/12</b>	<b>39,802</b>	<b>-79</b>

Most of the non-controlling interests are accounted for by H&R China Holding GmbH and its subsidiaries. The non-controlling interest in this company totals 49%. Because H&R AG holds the majority (51%) of voting rights and this is not offset by any restrictive minority rights, H&R AG exercises control. The table below shows a summary of financial data for H&R China Holding GmbH:

IN T€	31.12.2014
Current assets	72,613
Non-current assets	86,849
Current liabilities	69,958
Non-current liabilities	8,118
Net assets	81,386
Non-controlling interests' proportionate share of net assets	39,879

IN T€	Oct.-Dec. 2014
Earnings	25,403
Expenses	-25,796
<b>Net income/loss</b>	<b>-393</b>
Non-controlling interests' proportionate share of net income/loss	-192
<b>Other net income/loss</b>	<b>1,707</b>
Non-controlling interests' proportionate share of other net income/loss	836
<b>Total result</b>	<b>1,314</b>
Non-controlling interests' proportionate share of total result	644
<b>Current operations cash flow</b>	<b>-4,537</b>
Proportional current operations cash flow of non-controlling interests	-2,223
<b>Capital spending cash flow</b>	<b>-75</b>
Proportional capital spending cash flow of non-controlling interests	-37
<b>Free cash flow</b>	<b>-4,612</b>
Proportional free cash flow of non-controlling interests	-2,260
<b>Funding activity cash flow</b>	<b>18,849</b>
Proportional funding activity cash flow of non-controlling interests	9,236

## Notes to the consolidated income statement

#### (25) Research and development costs

In financial year 2014, research and development activities in the Chemical-Pharmaceuticals Division focused on optimising product qualities in the product areas of formulated oils, paraffins and white oils. Research and development costs were incurred in the Plastics Division for testing and experiments concerning new materials in the plastics area as well as research relating to the possibility of increased implementation of plastic components in various sectors.

Expenses incurred in 2014 for research and development amounted to €1,909 thousand (previous year: €1,906 thousand). For further information regarding research and development costs we refer the reader to the pertinent section in the Management Report.

## Notes

Notes to the consolidated income statement

## (26) Revenue

Sales revenue – less revenue reductions – is recognised at the time when the service is provided or upon the transfer of risk to the customer. The Segment Report gives an overview of the growth of sales by division and by geographical segment [see note (35)].

## (27) Other operating income

€ THOUSAND	2014	2013
Exchange rate gains from foreign currency items	5,822	8,659
Income from services	5,366	5,235
Income from passing on costs	2,986	2,877
Income from release of provisions	1,503	2,457
Income from rents and leases	1,115	818
Internally produced and capitalised assets	357	380
Income from commissions	356	356
Others	1,237	1,472
<b>Total</b>	<b>18,742</b>	<b>22,254</b>

The income from passing on costs results mainly from re-invoicing consumption taxes, project-related costs and other costs to the companies in which there is a participating interest, Westfalen Chemie GmbH & Co. KG and SRS EcoTherm GmbH.

## (28) Cost of materials

€ THOUSAND	2014	2013
Raw materials	700,758	810,247
Supplies	12,866	14,472
Trade goods	129,778	114,844
<b>Expenditure for raw, auxiliary and operating materials and for purchased goods</b>	<b>843,402</b>	<b>939,563</b>
Energy costs	35,843	38,544
Other external services	2,105	3,176
<b>Total expenditure on purchased services</b>	<b>37,948</b>	<b>41,720</b>
<b>Total</b>	<b>881,350</b>	<b>981,283</b>

## (29) Personnel expenses

€ THOUSAND	2014	2013
Wages and salaries	61,680	60,738
Social security payments	9,672	9,383
Benefit oriented pension plan expenses	853	783
Contribution oriented pension plan expenses	454	453
Other social security expenses	48	29
<b>Total</b>	<b>72,707</b>	<b>71,386</b>

Amounts arising from the interest compounding of personnel provisions, particularly pension provisions, are not reported as personnel expenses. They are reported with the interest income/expense as part of the financial result.

## AVERAGE NUMBER OF EMPLOYEES

	2014	2013
ChemPharm Refining	614	626
ChemPharm Sales	221	193
Plastics	578	569
Others	24	28
<b>Total</b>	<b>1.437</b>	<b>1.416</b>

## (30) Other operating expenses

€ THOUSAND	2014	2013
Freight costs, dispatch systems and other distribution costs	18,152	20,371
Third-party goods and services	12,009	11,896
Third-party repairs and maintenance	12,976	11,056
Loss from foreign currency translation	6,430	8,734
Rents and leases	8,031	8,015
IT costs	6,533	6,553
Legal and consultancy costs, costs for year-end accounts and shareholders' meeting	5,523	6,098
Other personnel costs	3,124	3,457
Commissions	2,553	3,076
Insurance premiums, fees and contributions	3,047	2,944
Costs passed on	2,973	2,847
Leasing costs	2,097	2,276
Travel expenses	1,046	895
Waste disposal	534	599
Waste and shortages	400	388
Others	6,922	6,008
<b>Total</b>	<b>92,350</b>	<b>95,213</b>

**(31) Net interest result**

€ THOUSAND	2014	2013
Interest income from short-term bank deposits	267	267
Income from loans	20	13
Other interest and similar income	225	29
<b>Interest income</b>	<b>512</b>	<b>309</b>
Interest expense relating to loan interest	-5,859	-6,301
Interest expenses from derivatives	-3,936	-4,044
Interest expense from the compounding of pension provisions	-2,293	-2,385
Early repayment fee	-	-350
Credit commission	-296	-795
Other interest and similar income	-1,939	-2,597
<b>Total interest expense</b>	<b>-14,323</b>	<b>-16,472</b>
<b>Net interest expense</b>	<b>-13,811</b>	<b>-16,163</b>

These include financial instruments broken down by the valuation categories of IAS 39:

€ THOUSAND	2014	2013
Loans and Receivables (LaR)	463	297
Financial Instruments Held for Trading (FAHfT und FLHfT)	-5,381	-4,039
Financial Liabilities Measured at Amortised Costs (FLAC)	-6,059	-9,659

**(32) Other financial result**

€ THOUSAND	2014	2013
Derivatives	4	3,563
Other financial expenses	-1	-163
Other financial income	148	25
<b>Total</b>	<b>151</b>	<b>3,425</b>

**(33) Taxes on earnings and income**

Since 1 January 2009, the net income of German companies has been subject to a uniform corporation tax rate of 15% plus a solidarity surcharge of 5.5%. In conjunction with a trade tax burden of 12.98% (prior year: 12.74%), this amounts to a combined income tax rate for the Group in Germany of 28.81% (prior year: 28.56%). Income tax rates for companies abroad are between 17% and 30%. The interest due on follow-up tax

payments has been included in interest expense. Deferred income tax expense includes changes in deferred tax assets and liabilities.

Taxes on income paid or owed in individual countries as well as tax accruals and deferrals are shown as income taxes. They are made up as follows:

€ THOUSAND	2014	2013
Current income tax expenses	-4,391	-4,274
Current income tax refunds	-	236
<b>Total current taxes</b>	<b>-4,391</b>	<b>-4,038</b>
Deferred taxes from timing differences	-3,551	753
Deferred taxes from loss carry-forwards	165	6,097
<b>Total deferred taxes</b>	<b>-3,386</b>	<b>6,850</b>
<b>Total</b>	<b>-7,777</b>	<b>2,812</b>

In accordance with IAS 12.34, the tax effect of a loss carried forward as of the reporting date is capitalised if it is sufficiently probable that there will in future be enough taxable profits to offset against the loss. In the financial year 2014, the German Tax fiscal unity group of the H&R AG recognised a loss. In total deferred tax assets of €11,049 thousand (prior year: €11,193 thousand) were recognized which relate to the tax losses carried forward of the H&R AG Fiscal unity group. Moreover deferred tax assets of €368 thousand (prior year: €284 thousand) are recognised for Group companies accounting a loss in the prior or the current year. The utilisation of the deferred tax assets is reliable as there will be sufficient future profits exceeding the effects on the result from the reversal of temporary differences.

As a result of revaluations of benefit oriented pension liabilities, deferred tax assets in the amount of €5.074 thousand (prior year: €387 thousand) were recognised in the other comprehensive income position without profit and loss effect. The termination of derivatives held for hedging purposes was the reason to reclass deferred taxes to the Consolidated income statement decreasing the Income after taxes in the amount of €380 thousand (prior year: €364 thousand). The variation in fair valued financial assets available for sale was the reason for deferred taxes recognised in the other comprehensive income position as non-profit and loss effective in the amount of €52 thousand (prior year: €2 thousand).

## Notes

Notes to the consolidated income statement

In addition to tax losses carried forwards which are considered for deferred tax assets there are corporate tax losses carried forward in the amount of €27,304 thousand (previous year: €5,067 thousand) and trade tax losses carried forward of €21,728 thousand (previous year: €231 thousand), whose realisation is not sufficiently guaranteed and for which no deferred tax assets have therefore been recognised. In accordance with the current tax law there is no risk of a tax loss carried forward expiration. Also no deferred tax assets are recognized for tax deductible temporary differences of T€ 3,375 (prior year: T€ 0).

For timing differences in retained earnings of subsidiaries in the amount of €5,964 thousand (previous year: €4,113 thousand) no deferred tax liabilities are recognised. The H&R Group is able to control the timing of the reversal of the temporary differences. Also the temporary differences will not reverse in the foreseeable future. Deferred tax liabilities of forecasted dividends were not recognised because the amounts are not material.

The tax rate reconciliation between the expected and the reported income taxes is represented as follows:

€ THOUSAND	2014	2013
<b>Earnings before taxes</b>	<b>-7,831</b>	<b>-16,849</b>
<b>Theoretical income tax expense 28.81% (prior year: 28.56%)</b>	<b>-2,256</b>	<b>-4,812</b>
Effects from tax rate differences	-1,161	-1,005
Effects from previous years' taxes	2,216	2,109
Tax effects from the reversing of deferred taxes	59	63
Non-deductible operating expenses	900	697
Goodwill Impairment	-	-217
Tax-exempt income	-292	-7
Foreign withholding tax	240	275
Tax rate change effects	100	-
Deferred tax assets of tax loss carried forwards not recorded	6,929	-
Utilization of tax loss carried forwards	-149	-
Deferred tax asset allowances	1,215	-
Other tax effects	-24	85
<b>Income tax expense per Group income statement</b>	<b>7,777</b>	<b>-2,812</b>

The total deferred tax assets and liabilities according to the Group Financial Statements derive from the following individual balance sheet items:

€ THOUSAND	31/12/2014		31/12/2013*	
	Deferred tax assets	Deferred tax liabilities	Deferred tax assets	Deferred tax liabilities
Intangible assets	1,238	11,894	866	4,235
Fixed assets	342	6,464	288	4,769
Financial assets	570	1,403	461	497
Inventories	250	837	154	60
Receivables and other assets	258	570	262	143
Provisions for pensions	11,165	-	5,824	-
Other provisions	356	86	830	72
Liabilities	1,338	119	2,374	302
Tax losses carried forward	11,611	-	11,446	-
<b>Subtotal</b>	<b>27,128</b>	<b>21,373</b>	<b>22,505</b>	<b>10,078</b>
of which long-term	15,014	19,218	9,820	9,698
Netting	-10,059	-10,059	-9,308	-9,308
<b>Total</b>	<b>17,069</b>	<b>11,314</b>	<b>13,197</b>	<b>770</b>

### (34) Earnings per share

Earnings per share are determined according to IAS 33 (Earnings per Share) by dividing net income by the weighted average number of ordinary shares in issue during the year. The capital increase as at September 25<sup>th</sup> 2014 led to an increase of subscribed capital of H&R Aktiengesellschaft. The average number of ordinary shares developed as follows:

	2014	2013
Number of shares issued at the beginning of the period	29,973,112	29,973,112
Additional shares issued on 25 September	5,847,042	–
Number of shares issued at the end of the period	35,820,154	29,973,112
Average number of shares in circulation	31,526.984	29,973,112

€ THOUSAND	2014	2013
Net profit/loss to shareholders in thousand €	-15,402	-14,029
Ordinary shares	31,526,984	29,973,112
Earnings per share (undiluted) in €	-0.49	-0.47
Earnings per share (diluted) in €	-0.49	-0.47

The diluted earnings per share ratio is equal to the basic earnings per share ratio, because H&R Aktiengesellschaft has not issued any potentially dilutive ordinary shares.

## Additional notes

### (35) Segment reporting

Pursuant to IFRS 8, the reporting operating segments were determined by identifying the individual divisions whose performance is monitored in the context of internal reporting as a basis for management decisions.

The summary listing of the operating segments subject to separate, internal reporting is performed in accordance with IFRS 8.12, which stipulates that all of the following must be comparable within each segment: the nature of products and services; the types of production processes;

the class or category of customers for products and services as well as the methods used to market products and services.

H&R AG has renamed the Chemical-Pharmaceutical Raw Materials Domestic segment as ChemPharm Refining. The ChemPharm Refining segment includes both the chemical-production sites in Germany where lubricant refining takes place and where the production processes, organizational structures and distribution networks are closely interlinked. This segment's main products are paraffins, white oils, plasticizers, base oils, lubricants and other crude-oil-based specialty products.

The Chemical-Pharmaceutical Raw Materials International segment was renamed as ChemPharm Sales. It encompasses foreign companies involved in the processing of chemical-pharmaceutical raw materials and in the distribution of these new products and other merchandise. These are mainly paraffins, plasticizers, wax emulsions and other crude-oil-based specialty products. In the future, the newly consolidated Chinese companies will therefore be part of the ChemPharm Sales segment.

The Plastics Division comprises the development, manufacture and sales of highly precise plastic parts produced using the injection moulding method.

“Other activities” are those associated with non-operating companies as well as segments exempt from mandatory reporting. This includes H&R AG, which as a holding company is responsible for the strategic leadership of the Group companies organised in the various segments and decides on the efficient allocation of funds within the Group. In addition, the other activities segment generates income from IT services and the leasing of land and buildings.

The list of shareholdings shows which segment each Group company belongs to.

The operating development of the segments and further information on their products and activities are described in the combined Management Report.



## Notes

## Additional notes

REMARKS CONCERNING SEGMENTAL DATA. Inter-company sales report the level of sales between the segments. Sales and proceeds between the segments are essentially accounted for on an arm's length basis. The sum of external and internal sales provides the segmental sales figure.

The consolidation column contains eliminations of all intercompany transactions as well as intra-divisional payables and receivables.

The valuation principles for H&R AG's segmental reporting are based on the IFRS guidelines applied in the consolidated financial statements.

The geographical distribution of external sales is calculated according to the locations of the respective customers. The assets and investments are assigned to the regions on the basis of the pertinent company's domicile.

€ THOUSAND	Chemical and Pharmaceutical Raw Materials			
	ChemPharm – Refining		ChemPharm – Sales	
	2014	2013	2014	2013
External sales	757,407	920,040	244,727	231,678
Intercompany sales	11,306	20,984	–	–
Sales by segment	768,713	941,024	244,727	231,678
Depreciation, amortization and impairments	-19,593	-32,177	-2,963	-1,538
of which impairment losses	-69	-12,077	–	–
Interest income	11	33	288	263
Interest expenses	-10,521	-13,302	-1,683	-1,201
Earnings before income taxes	-11,903	-24,830	16,072	14,004
EBIT	-1,394	-11,562	15,791	14,942
EBITDA	18,199	20,615	18,754	16,480
Assets	329,560	353,500	228,005	84,758
Debts	89,779	127,467	58,879	25,691
Capital expenditures	18,147	11,983	4,627	533
Result of shareholdings reported at-equity	124	284	–	–
Holdings in affiliates valued with the at-equity method	578	738	–	–

H&R AG generated sales of €553.7 million with one customer in the Chemical-Pharm Refining Segment (previous year: €639.4 million). External sales in the Chem-Pharm Refining segment

include revenues from services rendered totaling €67,130 thousand (previous year: €32,705 thousand). All other sales revenues are derived from the delivery of products.

## GEOGRAPHICAL INFORMATION

€ THOUSAND	Assets long-term		External sales	
	31/12/2014	31/12/2013	2014	2013
Germany	200,668	204,221	695,827	836,768
Rest of Europe	4,554	4,838	134,035	166,589
Rest of world	122,851	24,400	228,760	211,039
<b>Group</b>	<b>328,073</b>	<b>233,459</b>	<b>1,058,622</b>	<b>1,214,396</b>



Plastics		Others		Reconciliation		Total	
Plastics				Consolidation/Reconciliation			
2014	2013	2014	2013	2014	2013	2014	2013
56,488	62,678	-	-	-	-	1,058,622	1,214,396
-	-	-	-	-11,306	-20,984	-	-
56,488	62,678	-	-	-11,306	-20,984	1,058,622	1,214,396
-2,603	-2,215	-480	-804	-	-	-25,639	-36,734
-492	-	-	-	-	-	-561	-12,077
6	6	10,612	12,809	-10,405	-12,802	512	309
-1,526	-1,576	-10,994	-13,195	10,401	12,802	-14,323	-16,472
-5,647	-3,259	-6,267	-3,046	-86	282	-7,831	-16,849
-4,151	-1,552	-4,335	-6,221	-82	282	5,829	-4,111
-1,548	663	-3,855	-5,417	-82	282	31,468	32,623
37,936	37,964	27,344	27,510	83,772	90,924	706,617	594,656
10,243	8,561	8,921	14,816	289,892	228,959	457,714	405,494
802	610	130	21	-	-	23,706	13,147
-	-	-	85	-	-	124	369
-	-	185	185	-	-	763	923

## RECONCILIATION OF THE OPERATING RESULT TO THE CONSOLIDATED INCOME AFTER TAXES

€ THOUSAND

	2014	2013
Operating result of segments (EBITDA)	35,405	37,758
Reconciliation/Consolidation	-3,937	-5,135
<b>Operating result of H&amp;R AG (EBITDA)</b>	<b>31,468</b>	<b>32,623</b>
Depreciation	-25,639	-36,734
Financial result	-13,660	-12,738
Income Taxes	-7,777	2,812
<b>Income after taxes</b>	<b>-15,608</b>	<b>-14,037</b>

**Notes**

## Additional notes

**(36) Explanations on the consolidated statement of cash flows**

The cash flow statement has been prepared in accordance with the stipulations of IAS 7. It shows the origin and use of cash flows.

The statement of cash flows divides the payment streams into the three areas of operating business, investment activity and financing activity.

The reported financial resources consist of bank deposits, cash positions and cheques.

Net operating expenses, earnings and income from the sale of assets are eliminated from the cash flow from operating activities. Interest paid and interest received as well as income tax paid are allocated to this area. Cash flow from operating activities is calculated using the indirect method.

Cash flow from investment activities includes net investments in intangible, fixed and financial assets, including holdings consolidated for the first time in the financial year.

Cash flow from financing activity includes new and redeemed financial liabilities and liabilities from financial leasing and dividend payments.

The general form of presentation of the statement of cash flows and the utilisation of reporting options are unchanged from the previous period.

The cash flow statement is supplemented by a cash reconciliation.

**(37) Financial instruments****(37.1) General Information**

The original financial instruments primarily comprise other financial investments, receivables, short-term securities and cash and cash equivalents on the assets side. Financial assets available for disposal are reported at fair value. Other financial assets are reported at historical costs. The fair values of financial assets available for disposal are derived from the stock market prices or are calculated on the basis of recognised valuation methods. In the case of other financial assets, we work on the assumption that fair value corresponds to

the book value. On the liabilities side, financial instruments mainly contain liabilities valued at historical cost. The stock of financial instruments is reported in the balance sheet. The level of the financial assets corresponds to the maximum default risk. If default risks are identifiable with respect to financial assets, these risks are reported using value adjustments.

On the liabilities side, financial instruments mainly contain liabilities valued at historical cost. The stock of financial instruments is reported in the balance sheet. The level of the financial assets corresponds to the maximum default risk. If default risks are identifiable with respect to financial assets, these risks are reported using value adjustments.

As an international company, in the course of its ordinary business activities the H&R Group is exposed to risks from raw material prices, currency fluctuations and interest rate changes. Details concerning the risk management system used to deal with these risks can be found in note (46), Risk Management Policy, Capital Management and Hedging Measures.

**(37.2) Information concerning derivatives**

Derivative financial instruments are employed to hedge foreign exchange risks from the operating business and risks from changes in interest rates related to financing transactions. The types of instruments employed are primarily foreign currency forward transactions as well as interest rate hedging transactions such as caps and interest-rate swaps.

If the derivative is a component of a hedging contract (cash flow hedge) pursuant to IAS 39, a fair value modification of these derivatives is reported in other profit/(loss) without any impact on earnings until the underlying transaction is realised. The ineffective portion of these hedging transactions is reported in each case through the income statement in interest earnings. The result from the hedging transaction is booked out of equity and through the income statement at the time when the underlying transaction is realised. There were no balance sheet based hedging operations as at 31 December 2014.

The following tables show the reported fair values of the various derivative financial instruments as of 31 December 2014 and 31 December 2013.

#### DERIVATIVES WITHOUT HEDGE ACCOUNTING 2014

	Nominal value		Currency	Maturity	Carrying amounts 31/12/2014 € thousand
Interest rate swap	€ thousand	40,000	€	to 2016	-2,186
Interest rate swap	€ thousand	40,000	€	to 2018	-4,467
Currency forward	US\$ thousand	8,879	\$	to 2015	6

#### DERIVATIVES WITHOUT HEDGE ACCOUNTING 2013

	Nominal value		Currency	Maturity	Carrying amounts 31/12/2013 € thousand
Interest rate swap	€ thousand	40,000	€	to 2016	-2,338
Interest rate swap	€ thousand	40,000	€	to 2018	-3,942
Interest rate swap	€ thousand	10,000	€	to 2014	-187
Interest rate swap	€ thousand	5,000	€	to 2014	-95
Interest rate swap	€ thousand	5,000	€	to 2014	-95
Currency forward	US\$ thousand	12,078	\$	to 2014	-158

All subsequent changes in the fair value of the derivatives will be recognised immediately in profit or loss. As of 31 December 2014 the amount recognised in comprehensive income up to the end of the hedging relationship was €-3,916 thousand. It will be reversed through profit or loss over the remaining life of the derivatives. In financial year 2013, expenses arising from the reclassification to earnings for the period came to €1,330 thousand (previous year: €1,330 thousand). Correspondingly, pro rata deferred taxes amounting to €380 thousand (previous year: €363 thousand) were recognised as tax income.

In the 2014 financial year, the net loss on financial instruments measured at fair value through profit or loss totalled €244 thousand (previous year: net profit of €3,410 thousand). No reclassifications were made from equity to a non-financial asset or non-financial liability.

The hedging instruments were entered into based on a 3-month EURIBOR rate, which as of the balance sheet date of 31 December 2014 was quoted at 0.078%. An increase in the 3-month EURIBOR

of an average of 100 basis points would have a positive earnings effect of €1,220 thousand (previous year: €1,624 thousand) on the hedged loans while a decline in the EURIBOR of 50 basis points would have a negative earnings effect of €1,220 thousand (previous year: €1,624 thousand).

## Notes

## Additional notes

**(37.3) Maturity analysis**

The H&R Group's liquidity risk consists of contractually agreed obligations to make future interest rate and amortisation payments for financial liabilities and derivative financial instruments.

The maturities of these undiscounted payment streams are shown in the table below:

**2014**

€ THOUSAND	Book value	Cash flows 2015		Cash flows 2016	
		Interests	Redemption	Interests	Redemption
Trade accounts payable	112,415	–	112,415	–	–
Liabilities to banks	208,069	4,698	52,018	4,230	71,904
Finance lease liabilities	960	45	595	9	347
Liabilities arising out of derivatives without balance sheet based hedging relationships	6,653	2,275	2,308	2,269	2,030
Other financial liabilities	9,912	–	9,910	–	–

**2014**

€ THOUSAND	Cash flows 2017-2019		Cash flows 2020-2024		Cash flows 2025 ff.	
	Interests	Redemption	Interests	Redemption	Interests	Redemption
Trade payables	–	–	–	–	–	–
Liabilities to banks	4,928	77,897	178	6,250	–	–
Finance lease liabilities	–	18	–	–	–	–
Liabilities arising out of derivatives without balance sheet based hedging relationships	2,263	2,315	–	–	–	–
Other financial liabilities	–	–	–	2	–	–

**2013**

€ THOUSAND	Book value	Cash flows 2014		Cash flows 2015	
		Interests	Redemption	Interests	Redemption
Trade accounts payable	121,743	–	121,743	–	–
Liabilities to banks	181,541	5,211	13,312	4,867	9,455
Finance lease liabilities	1,442	64	595	19	470
Liabilities arising out of derivatives without balance sheet based hedging relationships	6,815	2,644	2,138	2,275	1,604
Other financial liabilities	1,904	2	1,895	1	4

**2013**

€ THOUSAND	Cash flows 2016-2018		Cash flows 2019-2023		Cash flows 2024 ff.	
	Interest	Amortisation	Interest	Amortisation	Interest	Amortisation
Trade payables	–	–	–	–	–	–
Liabilities to banks	9,076	145,024	518	13,750	–	–
Finance lease liabilities	16	377	–	–	–	–
Liabilities arising out of derivatives without balance sheet based hedging relationships	4,532	3,073	–	–	–	–
Other financial liabilities	–	3	–	2	–	–

**(37.4) Information on categories of financial instruments**

According to IFRS 7, financial assets and liabilities have to be grouped in such a way that a distinction can be made between financial instruments reported at actual cash value and others valued at historical cost.

The following table shows the book values of the individual financial instruments and liabilities for each individual financial instrument category. Together with the details of the financial instruments reported at fair value, the reconciliation against the balance sheet items serves to give the reader an insight into the type and nature of the financial instruments held by H&R AG.

31/12/2014

€ THOUSAND	Valuation category according to IAS 39	Balance sheet valuation acc. to IAS 39					Fair Value (for information)
		Book value	Acquisition costs carried forward	Fair Value without impact on net income	Fair Value with impact on net income	balance sheet assumptions according to IAS 17	
<b>Assets</b>							
Cash and cash equivalents	LaR	101,558	101,558				101,558
Trade accounts receivables	LaR	105,598	105,598				105,598
Other financial assets							
Loans and receivables	LaR	3,068	3,068				3,068
Other securities short-term	FAHfT	163			163		
Financial Assets Available for Sale	AfS	2,128	1,055	1,073			2,128
Other financial assets	LaR	889	889				889
<b>Passiva</b>							
Trade accounts payables	FLAC	112,415	112,415				112,415
Liabilities to banks	FLAC	208,069	208,069				217,859
Other financial liabilities							
Finance lease liabilities	FLAC	960				960	
Derivatives without hedging relationship	FLHfT	6,653			6,653		
Other financial liabilities	FLAC	9,912	9,912				9,912
Loans and Receivables	LaR	211,113	211,113				
Financial Assets Available for Sale	AfS	2,128	1,055	1,073			
Financial Assets Held for Trading	FAHfT	163			163		
Financial Liabilities Measured at Amortised Costs	FLAC	330,396	330,396				
Financial Liabilities Held for Trading	FLHfT	6,653			6,653		

## Notes

## Additional notes

31/12/2013

€ THOUSAND	Valuation category according to IAS 39	Balance sheet valuation acc. to IAS 39					balance sheet assumptions according to IAS 17	Fair value (for information)
		Book value	Acquisition costs carried forward	Fair Value without impact on net income	Fair Value with impact on net income			
<b>Assets</b>								
	LaR	109,624	109,624	-	-	-	109,624	
	LaR	109,725	109,725	-	-	-	109,725	
	LaR	1,721	1,721	-	-	-	1,721	
	FAHFT	297	-	-	297	-		
	AfS	2,048	1,055	993	-	-	2,048	
	LaR	889	889	-	-	-	889	
<b>Liabilities</b>								
	FLAC	121,743	121,743	-	-	-	121,743	
	FLAC	181,541	181,541	-	-	-	189,656	
		1,442	-	-	-	1,442		
	FLHFT	6,815	-	-	6,815	-		
	FLAC	719	719	-	-	-	719	
	LaR	221,959	221,959	-	-	-		
	AfS	2,048	1,055	993	-	-		
	FAHFT	297	-	-	297	-		
	FLAC	304,003	304,003	-	-	-		
	FLHFT	6,815	-	-	6,815	-		

Since trade account receivables and trade account payables, other financial assets and other financial liabilities as well as cash and cash equivalents generally have short-term maturities, their fair value will not deviate significantly from their carrying amount as of the reporting date. The actual cash value of other long-term receivables and liabilities with remaining maturities of more than one year will correspond to the cash value of their associated payments, subject to the relevant interest-rate parameter.

NET RESULTS BY VALUATION CATEGORY. The expenses, income, profits and losses arising from financial instruments can be broken down as follows:

€ THOUSAND	2014	2013
Loans and Receivables (LaR)	49	-17
Financial Instruments Held for Trading (FAHFT und FLHFT)	-30	3,280
Financial Liabilities Measured at Amortised Costs (FLAC)	155	136
<b>Total</b>	<b>174</b>	<b>3,399</b>

The total net profit amounting to €3,399 thousand does not include any interest or dividends.

**(37.5) Additional information concerning financial instruments**

GAUDLITZ GmbH holds financial assets for sale in the form of securities reported at fair value as of the reporting date. The reported market value was €1.073 thousand (previous year: €991 million).

The measurement of fair values on first level is based on quoted (non-adjusted) prices in active markets for similar assets or liabilities. If this

is not applicable, second level measurement is based on comparable market transactions directly or indirectly observable in the market. The third level uses models to measure fair values by means of parameters for the assessment of assets and liabilities that are based on non-observable market data.

Financial instruments of H&R AG recognised at fair value are allocated to the levels as described before as follows:

€ THOUSAND	31/12/2014			31/12/2013		
	Level 1	Level 2	Level 3	Level 1	Level 2	Level 3
<b>Assets</b>						
Financial Assets Available for Sale	1,073	–	–	991	–	–
Financial Assets Held for Trading	163	–	–	297	–	–
<b>Total</b>	<b>1,236</b>	<b>–</b>	<b>–</b>	<b>1,288</b>	<b>–</b>	<b>–</b>
<b>Liabilities and equity</b>						
Derivatives without hedging relationship	–	6,653	–	–	6,815	–
<b>Total</b>	<b>–</b>	<b>6,653</b>	<b>–</b>	<b>–</b>	<b>6,815</b>	<b>–</b>

The Level 2 financial liabilities are interest rate swaps carried on the balance sheet at their fair value. The fair values are determined by means of interest rate curves observable on the market. There were no reclassifications among the individual levels in financial year 2014.

The following table represents the allocation of the fair values of the financial instruments carried on the balance sheet at book value to the different levels:

**ALLOCATION OF FAIR VALUES OF FINANCIAL INSTRUMENTS**

€ THOUSAND	31/12/2014			31/12/2013		
	Level 1	Level 2	Level 3	Level 1	Level 2	Level 3
<b>Liabilities and equity</b>						
Liabilities to banks	–	217,859	–	–	189,656	–
<b>Total</b>	<b>–</b>	<b>217,859</b>	<b>–</b>	<b>–</b>	<b>189,656</b>	<b>–</b>

The fair values are determined by means of interest rate curves observable on the market. The expected payment flows were appropriately discounted. There were no reclassifications among the individual levels in financial year 2014.

No offsetting between financial assets and financial liabilities took place as no netting agreements were in existence.

For the presentation of market risks, IFRS 7 demands sensitivity analyses showing the impact of hypothetical changes in relevant risk variables on earnings and equity. This assumes that the position on the reporting date is representative of the whole year.

The open foreign currency positions of the most significant foreign currencies as of the reporting date are documented below.

## Notes

## Additional notes

## 31/12/2014

		US\$ thousand	GBP thousand	SAR thousand	AUD thousand	THB thousand
Cash and cash equivalents	+	11,724	3,555	74,863	14,151	940,517
Trade accounts receivable	+	6,619	1,260	217,874	5,404	228,620
of which currency hedged	-	8,879	-	-	-	-
Financial liabilities	-	2,357	243	204,460	5,831	279,097
of which currency hedged	+	-	-	-	1,556	-
<b>Net exposure</b>	=	<b>7,107</b>	<b>4,572</b>	<b>88,277</b>	<b>15,280</b>	<b>890,040</b>

## 31/12/2013

		US\$ thousand	GBP thousand	SAR thousand	AUD thousand	THB thousand
Cash and cash equivalents	+	3,529	2,124	30,480	5,849	810,880
Trade accounts receivable	+	12,058	1,532	160,173	5,374	220,552
of which currency hedged	-	9,209	-	-	-	-
Financial liabilities	-	2,001	931	129,710	1,987	333,411
<b>Net exposure</b>	=	<b>4,377</b>	<b>2,725</b>	<b>60,943</b>	<b>9,236</b>	<b>698,021</b>

For the currency risk, a sensitivity analysis is carried out using the US dollar as an example, as this is the most important foreign currency for the Group. The indirect quotation for the US dollar against the euro stood at US\$1.21/€ as of 31 December 2014, as against US\$1.38/€ as of 31 December 2013. Assuming a realistic range of fluctuation of +/-10% in the exchange rate as of the reporting date, the impact in terms of profit (+) or loss (-) would be as follows:

€ THOUSAND	2014		2013	
	US\$ 1.09/€	US\$ 1.34/€	US\$ 1.24/€	US\$ 1.52/€
Impact (before taxes)	650	-532	353	-289

A sensitivity analysis for interest rate risk is performed for loans with floating interest rates. As of the reporting date 31 December 2014 all floating rate loans were hedged against the effects of any changes in interest rates using appropriate instruments. Further information on this topic can be found in note (37.2).

In the operating business, the outstanding balances are continuously monitored at the divisional level, i.e. locally. Insofar as the Hansen & Rosenthal Group handles sales, details are also integrated into their monitoring system. Default risks are addressed by individual impairments and flat-rate impairments (additions).

Non-recoverable receivables are booked out and the difference is posted to the impairment account (used). When a doubtful receivable is realised, the previous impairment is cancelled (reversal).

The maximum default risk is given by the book values of the financial assets reported in the balance sheet, including free-standing derivatives with a positive market value. As of the reporting date, there are no material agreements in place that reduce the maximum default risk.



### (38) Order commitments

Investment expenses for which contractual obligations exist on the reporting date but which have not yet been incurred amount to:

€ THOUSAND	31/12/2014	31/12/2013
Fixed assets	1,712	3,686
Intangible assets	–	141
<b>Total</b>	<b>1,712</b>	<b>3,827</b>

### (39) Contingent liabilities

As of the balance sheet reporting date, the following contingent liabilities existed:

€ THOUSAND	31/12/2014	31/12/2013
Deposits for guarantees	1,187	1,187
Joint liability for pensions	61	72
<b>Total</b>	<b>1,248</b>	<b>1,259</b>

The outstanding liability contributions concern Westfalen Chemie GmbH & Co. KG.

Subsoil contaminated with compounds typical of explosives was discovered some time ago on a piece of land belonging to a Group company that was used to produce explosive materials. The investigations carried out to date have determined that the pollutants cannot be removed using current technology. The company is therefore focusing its ongoing measures on monitoring and securing the pollutants and supporting research projects into developing more advanced chemical/physical treatment methods. As the owner of the properties, the Sythengrund subsidiary is in principle liable for carrying out remediation of the legacy contamination. According to the case law of the German Federal Constitutional Court, liability for environmental pollution is generally limited to the market value of the property in a restored condition (BVerfG NJW 2000, 2573/2576). This liability cap may be adjusted up or down if additional circumstances so dictate. The liability cap could be reduced in light of the fact that the soil contamination is probably attributable to the production of armaments during the first and second world wars. In such a case, the authorities would

have to review whether the government, instead of the property owner, should bear primary liability for the legacy contamination.

Total provisions of €0.7 million have been set aside, based on estimates by independent experts. We believe that the expenditures already made and the provisions set aside are adequate to cover our portion of the remediation costs. It is currently unclear whether new methods will be developed in the future that would allow a clean-up to take place, thereby requiring additional expenses. This matter is the subject of ongoing monitoring by the Board. Negotiations are also being conducted with the Recklinghausen district – the regulating authority – to limit our liability for the risks described.

Part of the operating premises is rented. Clean-up obligations are required when the rental agreement is completed. Since claims for compensation will arise vis-à-vis lessors if they give extraordinary notice of termination or if the long-term rental agreement is not extended, no outflow of resources is assumed and thus no provision has been provided for reinstatement commitments. This circumstance is regularly monitored by the management.

Claims for damages in connection with the fine under competition law: from 2005 onwards, the European competition authority carried out investigations into possible collusive behaviour in the paraffin market between 1994 and 2005. In a ruling dated 1 October 2008, the Commission found various European wax manufacturers guilty of breaches of competition law. Companies in the Hansen & Rosenthal Group and H&R AG were fined a total of €36 million. H&R ChemPharm GmbH, which is part of the H&R Group, is jointly liable for €22 million of this amount. After a detailed examination of the grounds for the ruling, the companies lodged an appeal in December 2008, both against the reasoning and the amount of the fine. Notwithstanding the appeal, the sum of €22 million was paid in early 2009 within the deadline. With notice of 12 December 2014 from the court of the European Union the claim was overruled. Further legal action are subject to examination.

**Notes**

## Additional notes

**(40) Other financial obligations**

The financial obligations resulting from long-term rental and lease contracts as well as other obligations stretching over several years, become apparent from the following table (nominal amounts):

€ THOUSAND	31/12/2014	31/12/2013
Due within one year	8,363	8,164
Due > 1 year and < 5 years	10,939	11,401
Due > 5 years	22,456	23,929
<b>Total</b>	<b>41,758</b>	<b>43,494</b>

Other financial liabilities mainly include a maintenance agreement with XERUON GmbH, Cologne, and a long-term rental agreement with Hamburg Port Authority, Hamburg.

In addition, other financial liabilities at the Salzbergen location include contracts for the delivery of natural gas, compressed air and nitrogen as well as maintenance and servicing contracts regarding the process control system.

**(41) Governance bodies of H&R AG****EXECUTIVE BOARD**

	Membership of Supervisory or Advisory Boards
<b>Niels H. Hansen</b> Chairman of the Executive Board Hamburg	–
<b>Detlev Wösten</b> Member of the Executive Board Refineries Buchholz	Member of the Supervisory Board of Glasgard AG, Lollar/Salzböden
<b>Luis Rauch</b> Chief Financial Officer (until 31/8/2013) Hamburg	–

**SUPERVISORY BOARD**

	Membership of Supervisory or Advisory Boards
<b>Dr Joachim Girg</b> Chairman of the Supervisory Board, Managing Director of H&R Beteiligung GmbH, Hamburg	Member of the Supervisory Board of Hamburger Getreide-Lagerhaus Aktiengesellschaft, Hamburg
<b>Roland Chmiel</b> Deputy Chairman Auditor, Partner of Partnership Weiss-Walter-Fischer-Zernin, Munich	Member of the Supervisory Board of Togonal AG, Munich
<b>Nils Hansen</b> Managing partner of companies of the H&R Group, Hamburg	Member of the Supervisory Board of Otto M. Schröder Bank Aktiengesellschaft, Hamburg
<b>Dr Rolf Schwedhelm</b> Tax lawyer and Partner at Streck Mack Schwedhelm, Cologne	Chairman of the Supervisory Board of German Lawyer Academy Society for Education and Training and Services mbH, Berlin
<b>Anja Krusel</b> (since 31.05.2012) CFO of Microsoft Deutschland GmbH, Munich	–
<b>Dr Hartmut Schütter</b> (since 31/5/2013) Consulting Engineer, Schwedt/Oder	–

**SUPERVISORY BOARD (EMPLOYEE REPRESENTATIVES)**

Membership of Supervisory or Advisory Boards	
<b>Reinhold Grothus</b> Chairman of the Works Council H&R ChemPharm GmbH, Salzbergen	–
<b>Rainer Metzner</b> Sales Manager – Medical Chairman of the Works Council GAUDLITZ GmbH, Coburg	–
<b>Harald Januszewski</b> GAUDLITZ GmbH, Coburg	–

**(42) Disclosures of relationships with related parties according to IAS 24**

Transactions with related parties were carried out on arm's-length terms.

The following goods and services have been rendered for related companies and persons who might exercise a significant degree of influence, or utilised by them:

**TRANSACTIONS WITH HANSEN & ROSENTHAL**

€ THOUSAND	Transactions to Hansen & Rosenthal		Transactions from Hansen & Rosenthal	
	2014	2013	2014	2013
Supplies of chemical pharmaceutical products	393,795	639,382	103,266	28,496
of which Salzbergen	–	227,290	–	–
of which Hamburg	375,123	395,633	–	–
Ancillary costs from delivery transactions (freight costs, road tolls, etc.)	–	–	3,812	4,802
Commission fees	799	528	1,569	1,935
Other services and passed-through third party related costs (e.g. EDP services and personnel costs)	71,201	6,385	1,013	169

All companies of the majority shareholder Nils Hansen, including H&R Beteiligung GmbH as the controlling company, are pooled under Hansen & Rosenthal (H&R). During the current year, there were no business transactions involving H&R Beteiligung GmbH.

The supply of goods for chemical-pharmaceutical products from the Salzbergen site takes place under a long-term distribution and supply contract, by which the relevant Hansen & Rosenthal company purchases the products and then resells them to end customers in its own name and for its own account. In addition, Hansen & Rosenthal receive a commission fee for deliveries from the Hamburg site included in a long-term commission contract for marketing of certain products. Moreover, IT as well as staffing services are provided to the Hansen & Rosenthal Group by subsidiaries of the H&R Group.

Hansen & Rosenthal group sold 51% of its shares of H&R China Holding GmbH to H&R AG and received new shares. Further details can be found in notes (5) and (24).

As part of a €10,150 thousand capital increase at H&R China Holding GmbH, the Hansen & Rosenthal Group made a cash contribution, proportional to its shareholding, of € 4,954 thousand.

## Notes

## Additional notes

The following receivables and liabilities existed as of 31 December 2014:

**RECEIVABLES AND LIABILITIES DUE TO HANSEN & ROSENTHAL**

€ THOUSAND	Receivables from Hansen & Rosenthal		Liabilities to Hansen & Rosenthal	
	31/12/2014	31/12/2013	31/12/2014	31/12/2013
Goods and services	16,004	25,956	14,831	3,517
Other services	28,574	36,404	6,033	86
<b>Total</b>	<b>44,578</b>	<b>62,360</b>	<b>20,864</b>	<b>3,603</b>

Trade account receivables from Hansen & Rosenthal in the amount of €7,482 thousand were sold to banks as part of factoring agreements without recourse.

sand, previous year: €36,398 thousand), where Hansen & Rosenthal, as commission agent, receives payments from customers and forwards them to H&R AG.

Other receivables mainly concern receivables from the commission business (€28,570 thou-

The following services were rendered for joint ventures, or utilised by them:

**TRANSACTIONS WITH JOINT VENTURES**

€ THOUSAND	Provided to joint ventures		Received from joint ventures	
	2014	2013	2014	2013
Purchase of hydrogen and steam	–	–	1,840	1,566
Interest income	15	6	–	–
Rental income	41	41	–	–
Services	1,078	1,578	4,356	4,513
<b>Total</b>	<b>1,134</b>	<b>1,625</b>	<b>6,196</b>	<b>6,079</b>

The following receivables and liabilities existed as of 31 December 2014:

**RECEIVABLES AND LIABILITIES DUE TO JOINT VENTURES**

€ THOUSAND	Receivables from joint ventures		Liabilities owed to joint ventures	
	31/12/2014	31/12/2013	31/12/2014	31/12/2013
Goods and services	488	281	205	189
Other services	375	535	–	–
<b>Total</b>	<b>863</b>	<b>816</b>	<b>205</b>	<b>189</b>

SUPERVISORY BOARD AND EXECUTIVE BOARD. For fulfilling their tasks, the members of the Supervisory Board received a total of €840 thousand (previous year: €1,402 thousand). Of this sum, the performance-related element of the remuneration accounted for €235 thousand (previous year: €276 thousand). Former members of the Executive Board and their surviving dependants received a total remuneration of €208 thousand (previous year: €233 thousand). For former mem-

bers of the Executive Board and their surviving dependants, the pension commitments totalled €3,412 thousand (previous year: €3,289 thousand).

The remuneration of the individual members of the Executive Board and the Supervisory Board of H&R AG is composed as follows:

## EXECUTIVE BOARD REMUNERATION

IN €	Niels H. Hansen		Detlev Wösten		Luis Rauch		Total	
	Chairman of the Executive Board		Member of the Executive Board Refineries		Chief Financial Officer			
	Chairman of the Executive Board since 1 January 2012		Member of the Executive Board since 1 August 2011		Member of the Executive Board from 1 January 2012 to 31 August 2013			
	2014	2013	2014	2013	2014	2013	2014	2013
Fixed compensation*	356,747	284,702	231,747	194,077	–	294,933	588,494	773,712
Fringe benefits**	251	251	16,478	14,741	–	337,770	16,729	352,762
<b>Subtotal</b>	<b>356,998</b>	<b>284,953</b>	<b>248,225</b>	<b>208,818</b>	<b>–</b>	<b>632,703</b>	<b>605,223</b>	<b>1,126,474</b>
Variable remuneration***	92,750	74,375	141,750	126,500	–	75,000	234,500	275,875
<b>Total</b>	<b>449,748</b>	<b>359,328</b>	<b>389,976</b>	<b>335,318</b>	<b>–</b>	<b>707,703</b>	<b>839,723</b>	<b>1,402,349</b>

\* In accordance with the resolution of the Supervisory Board meeting on August, the 22nd, 2013 the Executive Board voluntarily decided for 15% less of their fixed compensation for the months August through December 2013.

\*\* This sum also includes use of company cars and accident insurance contributions as well as payments in relation to the leaving compensation Executive Board member Luis Rauch amounting to € 330 thousand.

\*\*\* The Executive Board did not receive any long-term variable remuneration for years 2012 and 2013.

In the financial year, the members of the Supervisory Board received a total of €293 thousand (previous year: €264 thousand).

## SUPERVISORY BOARD REMUNERATION

IN €	Fixed remuneration		Remuneration for Supervisory Board activities		Variable remuneration		Total	
	2014	2013	2014	2013	2014	2013	2014	2013
Dr Joachim Girm (Chairman)	60,000	56,250	20,000	20,000	–	–	80,000	76,250
Roland Chmiel (Deputy Chairman)	30,000	28,125	15,000	15,000	–	–	45,000	43,125
Nils Hansen	20,000	18,750	10,000	10,000	–	–	30,000	28,750
Dr Rolf Schwedhelm	20,000	18,750	2,500	2,500	–	–	22,500	21,250
Anja Krusel	20,000	18,750	7,500	7,500	–	–	27,500	26,250
Dr Hartmut Schütter	20,000	7,572	5,000	1,555	–	–	25,000	9,127
Reinhold Grothus	20,000	18,750	2,500	2,500	–	–	22,500	21,250
Harald Januszewski	20,000	18,750	–	–	–	–	20,000	18,750
Rainer Metzner	20,000	18,750	–	–	–	–	20,000	18,750
<b>Total Supervisory Board</b>	<b>230,000</b>	<b>204,447</b>	<b>62,500</b>	<b>59,055</b>	<b>–</b>	<b>–</b>	<b>292,500</b>	<b>263,502</b>

The employee representatives on the Supervisory Board receive remuneration that is not related to their work for the Supervisory Board in addition to their Supervisory Board remuneration. This remuneration came to a total of €177 thousand in financial year 2014 (previous year: €174 thousand). Further details are provided in the remuneration report, which forms part of the management report.

In October of 2012, H&R AG established an Advisory Board, which advises the Executive Board. Expenses of €120 thousand were incurred for the activities of the Advisory Board in 2014 (prior year: €90 thousand). In 2014, fees paid to members of the governing bodies of H&R AG within the scope of consultant agreements amounted to €107 thousand (prior year: €105 thousand). As of 31 December 2014, liabilities in the amount of

**Notes**

## Additional notes

€321 thousand (prior year: €297 thousand) existed in regard to members of the governing bodies.

**(43) Declaration of conformity in accordance with Article 161 AktG rung nach § 161 AktG**

The declaration on the German Corporate Governance Code specified by Article 161 of the German Companies Act (AktG) was submitted on 20 February 2015. It is published on the Internet at [www.hur.com](http://www.hur.com) and is included in this annual report.

**(44) Group audit expenses recorded as expenditure in the financial year**

The following fees for services of PricewaterhouseCoopers Aktiengesellschaft Wirtschaftsprüfungsgesellschaft were recognized as expenses:

€ THOUSAND	31/12/2014	31/12/2013
Audits	496	407
Other certification or valuation services	130	43
Tax consultancy services	8	–
Other services	12	–
<b>Total</b>	<b>646</b>	<b>450</b>

Audit fees include the amounts paid for auditing the consolidated financial statements and for the statutory audits of the financial statements of H&R AG and its subsidiaries.

**(45) Exemption from disclosure under Article 264 Paragraph 3 HGB**

The following fully consolidated subsidiaries have elected to make use of the opportunity to be released from the requirement of disclosure in accordance with Article 264 Paragraph 3 in conjunction with Article 325 of the German Commercial Code (HGB), and partly made use of concessions regarding audits and the preparation of their financial statements:

- H&R Ölwerke Schindler GmbH
- H&R Chemisch-Pharmazeutische Spezialitäten GmbH
- GAUDLITZ GmbH
- H&R Lube Blending GmbH
- H&R ChemPharm GmbH
- H&R Lube Trading GmbH

- H&R International GmbH
- H&R InfoTech GmbH
- H&R South Africa GmbH
- SYTHENGRUND Wasagchemie Grundstücksverwertungsgesellschaft Haltern mbH

**(46) Risk management policy, capital management and safeguards**

However, the operating business as well as the financing transactions of the H&R Group, as an internationally active company, are subject to different financial risks. These specifically include liquidity risk and counterparty default risk, as well as risks associated with fluctuations in raw material prices, currency exchange rates and interest rates. These risks are limited through systematic risk management measures, such as hedging transactions.

H&R AG has implemented a Group-wide risk management system, which serves as the basis for identifying, analysing and valuing these risks, so that informed decisions can then be taken with regard to preventing or limiting such risks. The key components of the risk management systems are planning and controlling, Group-internal regulations and reporting. Regular conferences are held to discuss current business developments, operational results, potential risks and opportunities, objectives and management procedures. Derivative financial instruments are also utilised in this context. The purchase of derivative financial instruments for speculative purposes is not permitted. All transactions with derivative financial instruments must be approved by the Executive Board.

The Group companies are subject to strict risk management. Dealing authorisations, responsibilities and supervision procedures are established on a binding basis in internal guidelines. In this respect, derivative financial instruments may not, as a matter of principle, be implemented for speculative purposes, but instead serve to hedge against risks in connection with the operating business. Credit risk exposure to contractual partners is investigated systematically at the time of signing a contract and monitored on an ongoing basis. In addition to this, credit risk is reduced using appropriate types of security.

The Executive Board defines the equity of the Group as the basic parameter for capital management, which in turn serves to ensure that the Group can continue to cover its investment needs and debt service. In this context, the H&R Group tries to achieve a capital structure that optimises the costs of capital provided both by lenders and by investors. Further important basic parameters with regard to our capital structure are net debt

and net gearing which describes the ratio between net debt and equity. These ratios are subject to permanent surveillance by the Executive board.

Due to the bond loans, the syndicated loans and the bilateral loans H&R AG is obliged to meet the financial covenants that are connected to the relation of net debt to operational result (EBITDA) and the financial equity ratio.

#### CAPITAL STRUCTURE

€ MILLION	2014	2013	2012	2011	2010
Net Debt / EBITDA	3.41	2.24	2.97	2.15	1.08
Equity ratio in %	35.2	31.8	34.2	38.0	42.5
Net gearing in %	45.8	42.2	73.4	79.4	49.2

**LIQUIDITY RISKS** The H&R Group ensures that it has sufficient liquidity by monitoring its liquidity status daily and by means of financing facilities that have not been used in full. Compliance with financial covenants is a crucial part of the financing agreements. If these covenants were to be breached again and could not be renegotiated this would jeopardise the continued existence of the Group. We are countering the risk of a repeated breach of financing conditions by means of an extensive, and in the opinion of the Executive Board, sustainable series of activities to reduce debt and improve earnings. They comprise the greater use of factoring, a modified commission model for our distribution partners, which improves margins for H&R AG, converting the Salzbergen site to contract processing and an optimised financing structure.

**DEFAULT RISK** The risks arising from delays in payment or defaults on the part of our customers are limited by our broadly diversified customer base and the low level of dependence on individual debtors. Strict receivables management by our sales partner Hansen & Rosenthal reduces these risks even further. Trade credit insurance has also been taken out for a number of major customers. The default risk for banks with which we have arranged credit lines, hedged transactions or invested funds has increased since the outbreak of the financial crisis. We address this risk by only

completing financial transactions with institutions that have exemplary ratings and by spreading larger transactions among several banks.

**RAW MATERIALS PRICE RISK.** The H&R Group is exposed to price fluctuation risks among other things in the purchasing of raw materials, particularly the purchasing of atmospheric residue and vacuum gas oil. Most supply agreements concluded with customers relating to specialty products manufactured by the Chemical-Pharmaceutical Raw Materials Division's specialty refineries incorporate prices fixed for a period of three months at the most. A specialty refinery's production process, from the delivery of raw materials to the supply of the finished product to the customer, can take up to eight weeks. This means that rapid increases in raw materials costs cannot be passed on immediately to markets but only with a time delay. Relevant price developments are subject to constant monitoring and analysis. Rising raw materials prices may result in windfall losses in earnings, and falling raw materials prices may lead to windfall profits, which will, as a rule, balance out over time.

**FOREIGN CURRENCY RISKS.** The international alignment of the H&R Group means that its operating activities give rise to currency risks, among other things, that result from exchange-rate fluctuations between the company's currency and

**Notes**

## Additional notes

other currencies. These arise particularly in the purchasing area as a result of US dollar transactions. Such risks are hedged using forward transactions in the trading business. Hedging is not performed in the production process, as the length of time entailed in the production process means that the intended hedge may be reversed by the time that the currency forward transaction has concluded.

**INTEREST RATE RISKS.** The H&R Group employs variable interest-rate facilities, among other things, as part of its financing activities. Interest hedging instruments are implemented to limit risks arising from changes in market interest rates. These concern interest rate caps and interest rate swaps. Such transactions may be entered into on a decentralised basis within the H&R Group but require the prior approval of the Executive Board. Further information concerning financial instruments can be found in note (37).

**(48) Events after the reporting date**

Effective 1 January 2015, H&R AG sold two parcels of land from the portfolio of SYTHENGRUND WASAGCHEMIE Grundstücksverwertungsgesellschaft Haltern mbH. The company reported a gain of €295,000 on the properties, which were formerly used in connection with the production of explosives.

**(49) Approval of the financial statements**

The financial statements were approved by the Executive Board on 27 February 2015, and released for publication.

Salzbergen, 27 February 2015

The Executive Board

Niels H. Hansen

Chairman  
of the Executive Board

Detlev Wösten

Member  
of the Executive Board

**Attestation by the legal representatives**

We hereby affirm that, to the best of our knowledge and according to the applicable accounting standards, the consolidated financial statements convey a true picture of the financial position and financial performance and the results of operations of the Group and that the combined management report presents the course of business including operating profits and the situation of the Group in such a way that a true and fair view is presented and the material opportunities and risks to the projected development of the Group are described.

Salzbergen, 27 February 2015

The Executive Board

Niels H. Hansen

Chairman  
of the Executive Board

Detlev Wösten

Member  
of the Executive Board



## Auditor's Report

We have audited the consolidated financial statements prepared by the H&R Aktiengesellschaft, Salzbergen, comprising the statement of financial position, the income statement and statement of comprehensive income, statement of changes in equity, cash flow statement and the notes to the consolidated financial statements, together with the group management report, which is combined with the management report of the H&R Aktiengesellschaft, Salzbergen for the business year from January 1st to December 31st 2014. The preparation of the consolidated financial statements and the combined management report in accordance with the IFRSs, as adopted by the EU, and the additional requirements of German commercial law pursuant to § (Article) 315a Abs. (paragraph) 1 HGB ("Handelsgesetzbuch": German Commercial Code) are the responsibility of the parent Company's Board of Managing Directors. Our responsibility is to express an opinion on the consolidated financial statements and the combined management report based on our audit.

We conducted our audit of the consolidated financial statements in accordance with § 317 HGB and German generally accepted standards for the audit of financial statements promulgated by the Institut der Wirtschaftsprüfer (Institute of Public Auditors in Germany) (IDW). Those standards require that we plan and perform the audit such that misstatements materially affecting the presentation of the net assets, financial position and results of operations in the consolidated financial statements in accordance with the applicable financial reporting framework and in the combined management report are detected with reasonable assurance. Knowledge of the business activities and the economic and legal environment of the Group and expectations as to possible misstatements are taken into account in the determination of audit procedures. The effectiveness of the accounting-related internal control system and the evidence supporting the disclosures in the consolidated financial statements and the combined management report are examined primarily on a test basis within the framework of the audit. The audit includes assessing the annual financial statements of those entities included in consolidation, the determination of the entities to be included in consolidation, the accounting and consolidation principles used

and significant estimates made by the Company's Board of Managing Directors, as well as evaluating the overall presentation of the consolidated financial statements and the combined management report. We believe that our audit provides a reasonable basis for our opinion.

Our audit has not led to any reservations.

In our opinion based on the findings of our audit the consolidated financial statements comply with the IFRSs as adopted by the EU and the additional requirements of German commercial law pursuant to § 315a Abs. 1 and give a true and fair view of the net assets, financial position and results of operations of the Group in accordance with these provisions. The combined management report is consistent with the consolidated financial statements and as a whole provides a suitable view of the Group's position and suitably presents the opportunities and risks of future development.

Hamburg, February 27<sup>th</sup>, 2015

PricewaterhouseCoopers  
Aktiengesellschaft  
Wirtschaftsprüfungsgesellschaft

Niklas Wilke                      ppa. Christoph Fehling  
(German Public Auditor)      (German Public Auditor)





## Glossary

### Barrel

Unit of measurement for liquid; in relation to oil products, a barrel contains 159 litres.

### Blending

In the production of lubricants, blending refers to the mixing of oil and additives to form automotive and industrial lubricants.

### Brent

Leading type of oil from the North Sea.

### Cash flow

Key financial figure: cash balance of inflow and outflow of funds; split between current operations, investment activity and financing activity.

### CONCAWE Standard

Safety figures LWIF (lost workday injury frequency) and LWIS (lost workday injury severity). The LWIF figure shows the frequency of accidents (number of work accidents with at least 1 day lost for every 1 million working hours). The LWIS figure shows the severity of accidents (number of days lost per work accident).

### Earnings per Share

Key financial figure: net income for year divided by the weighted average number of outstanding shares; shows how high the profit is for each share.

### EBITDA

(Earnings before interest, taxes, depreciation and amortisation) Key financial figure: defined as consolidated earnings before interest earnings, taxes on income as well as depreciation on tangible assets and amortisation of goodwill. In the case of H&R, operation income.

### Equity Ratio

Key financial figure: shows the ratio of equity to total assets and represents the finance structure.

### Free cash flow

Key performance indicator: the sum of cash flow from operating activities and cash flow from investing activities; provides information about the liquid funds held after capital expenditure has been deducted.

### German Corporate Governance Code

Recommendations and suggestions on conduct from the governmental commission of the same name on corporate management and supervision for listed companies in Germany.

### Group I Refinery

Refineries can be divided into various groups (Groups I to IV). This is done by reference to various properties of the base oil, such as the sulphur content and the viscosity index.

### Net Debt

Differing from the financial indicator of net financial debt, which consist of financial liabilities less liquid funds, current financial assets and derivative financial instruments measured at fair value, the net debt definition as basis of calculation for the covenants contains alternate parameter, founding on the financial agreements; provides information on the amount of debt remaining if all liquid funds were used to repay existing liabilities.

**Net Gearing Ratio**

Key performance indicator: the ratio of net financial debt to equity; provides an insight into the financing structure.

**Net Working Capital**

Key performance indicator: net working capital is defined as trade receivables plus inventories less trade payables.

**Paraffin**

Products of special refinery production: paraffin is oil-based wax which is used in over 100 different industries and sectors for manufacturing a wide variety of products.

**Plasticisers**

Product of special refinery production: extracts are used as softening agents in the rubber and caoutchouc industry (in particular in tyre production).

**Propane Deasphalting Unit (PDU)**

Extraction unit which produces deasphalted oil and asphalt from vacuum residue using propane as solvent.

**Return on Capital Employed (ROCE)**

Key performance indicator: the ratio of EBIT to average capital employed (equity plus net financial debt, pension provisions and other non-current provisions); crucial for value-based corporate management at H&R AG.

**Return on Equity**

Key performance indicator: the ratio of profit (consolidated net profit before minority interests) to average equity; provides information about the amount of interest paid on capital from equity providers.

**Special Refinery Activities**

Production of highly refined raw materials for the chemical and pharmaceutical industries using oil-based materials.

**Syndicated Loan**

Granting of a fixed credit line for a specified period of time by a consortium of several banks.

**Tool**

Designation for the injection mould in the manufacture of plastic parts.

**Value Creation**

Increase in value of goods used in the production process.

**WACC**

Weighted Average Cost of Capital

**White Oil**

Product of special refinery production: highly refined and purified oil which is used especially as an input material in the cosmetics and polystyrene industries.

## List of graphics and tables

## List of graphics and tables\*

Number	Graphic	Page	Number	Table	Page
G. 01	Performance of the H&R share, DAX, SDAX	40	T. 01	The H&R Group in figures	U3
G. 02	Highest and lowest prices of the H&R share, full year 2014	41	T. 02	The segments in figures	U3
G. 03	Shareholder structure as of 31/12/2014	42	T. 03	Executive committee	27
G. 04	Presentation of Group structure	47	T. 04	Meeting and telephone conferences	28
G. 05	Exchange rates US\$ per € in 2014	53	T. 05	Directors' dealings 2014	35
G. 06	Oil prices 2009–2014	53	T. 06	Executive Board remuneration	38
G. 07	Revenue by segment in 2014	58	T. 07	Executive Board remuneration	38
G. 08	Revenue by region in the chemical-pharmaceutical raw materials domestic segment in 2014	58	T. 08	Supervisory Board remuneration	39
G. 09	Revenue by region in the chemical-pharmaceutical raw materials international segment in 2014	59	T. 09	Basic data on the H&R share	41
G. 10	Revenue by region in the plastics segment in 2014	59	T. 10	Key share data	42
G. 11	Investment by region 2014	62	T. 11	Research-Coverage of the H&R share	43
G. 12	Assets and liabilities	63	T. 12	Main sites in the H&R Group	47
G. 13	Global economic growth forecast	79	T. 13	Free cash flow	50
G. 14	Risk management control system	84	T. 14	Capital structure	51
			T. 15	Earnings and volume growth	51
			T. 16	Research and development costs	52
			T. 17	Forecast for financial year 2014	55
			T. 18	Development of revenue and earnings	57
			T. 19	Development of main items in the income statement	58
			T. 20	Key figures for the segments (IFRS)	59
			T. 21	Main financing instruments in the H&R Group	60
			T. 22	Financial position	61
			T. 23	Capital expenditure in the segments	61
			T. 24	Net capital expenditure volume	62
			T. 25	Employees by division	64
			T. 26	Occupational safety at the H&R refineries	65
			T. 27	Emissions by H&R refineries	67
			T. 28	Earnings position of H&R AG under HGB	70
			T. 29	Financial and asset position of H&R AG	71
			T. 30	Comparison of actual values with forecast	79
			T. 31	Potential financial impact	86
			T. 32	Corporate risks	86

\* The tables in the consolidated financial statements are not listed.

## Six-year overview H&amp;R Group key figures (IFRS)

		2014	2013	2012	2011	2010	2009
Sales volume (main products) <sup>1)</sup>	KT	697	734	839	872	932	812
Revenue	€ MILLION	1,058.6	1,214.4	1,228.9	1,209.5	1,056.8	762.3
Operating result (EBITDA)	€ MILLION	31.5	32.6	49.4	89.1	103.4	65.6
EBIT	€ MILLION	5.8	-4.1	25.5	68.1	82.0	44.7
Earnings before taxes	€ MILLION	-7.8	-16.8	1.6	54.5	73.6	36.2
Consolidated earnings (before minority interests)	€ MILLION	-15.6	-14.0	0.4	38.5	52.0	25.1
Group profit/(loss) after minority interests	€ MILLION	-15.4	-14.0	0.5	38.5	52.0	25.0
Consolidated earnings per share (undiluted)	€	-0.49	-0.47	0.02	1.29	1.74	0.83
Dividend per share	€	0	0	0	0.6	0.65	0.45
Market capitalisation as at 31/12	€ MILLION	270.1	260.7	354.4	496.1	630.9	449.0
Balance sheet total	€ MILLION	706.6	594.7	623.1	636.6	532.4	462.4
Net Working Capital	€ MILLION	127.4	104.2	188.9	265.0	202.2	161.9
Equity	€ MILLION	248.9	189.2	213.3	236.7	226.4	181.7
Equity capital share	%	35.2	31.8	34.2	37.2	42.5	39.3
Net indebtedness	€ MILLION	107.3	73.1	146.3	183.4	110.4	117.1
Net gearing	%	45.8	38.6	68.6	77.5	48.8	64.5
Operating cash flow	€ MILLION	-0.4	88.9	84.7	-11.8	52.1	21.5
Free cash flow	€ MILLION	-10.5	72.8	50.9	-54.2	19.3	-2.1

<sup>1)</sup> Chemical-Pharmaceutical Raw Materials Division.

## Adjusted key figures (IFRS)

		2014	2013	2012	2011	2010	2009
Adjusted operating income (EBITDA)	€ MILLION	31.5	32.6	49.4	89.1	103.4	65.6
Adjusted EBIT	€ MILLION	5.8	-4.1	25.5	68.1	82	44.7
Adjusted pre-tax earnings	€ MILLION	-7.8	-16.8	1.6	54.5	73.6	36.2
Adjusted EBITDA margin	%	3.0	2.7	4	7.4	9.8	8.6
Adjusted return on equity	%	n.a.	n.a.	0.1	16.3	25.6	14.4

## Financial calendar



Our financial calendar is updated on an ongoing basis. Please visit our website [www.hur.com](http://www.hur.com) in the Investor Relations section for the latest events.

---

13 February 2015	Publication of provisional figures for financial year 2014
17 March 2015	Publication of Final Figures 2014, Press and Analysts' Conference
15 May 2015	Publication of Q1 Report 2015
19 May 2015	Annual Shareholders' Meeting, Hamburg
14 August 2015	Publication of Q2 Report 2015
13 November 2015	Publication of Q3 Report 2015

---



## Contact

If you have further questions concerning our company or if you would like to sign up for the company mailing list, please contact our Investor Relations Team:

### H&R AG

Investor Relations  
Am Sandtorkai 50  
20457 Hamburg  
www.hur.com

### Ties Kaiser

Phone: +49 (0) 40-43218-321  
Fax: +49 (0) 40-43218-390  
Email: ties.kaiser@hur.com

## Imprint

### Published by:

#### H&R AG

Neuenkirchener Straße 8  
48499 Salzbergen  
Germany

### Concept/Design:

Berichtsmanufaktur GmbH, Hamburg

This Annual Report was published on  
17 March 2015.

## Disclaimer

### Forward-looking statements

This document contains forward-looking statements that reflect management's current views with respect to future events. Such statements are subject to risks and uncertainties that are beyond H&R's ability to control or estimate precisely, such as future market and economic conditions, the behavior of other market participants, the ability to successfully integrate acquired businesses and achieve anticipated synergies and the actions of government regulators. If any of these or other risks and uncertainties occur, or if the assumptions underlying any of these statements prove incorrect, then actual results may be materially different from those expressed or implied by such statements. H&R does not intend or assume any obligation to update any forward-looking statements to reflect events or circumstances after the date of these materials.

### Variations for technical reasons

For technical reasons (e. g. conversion of electronic formats) there may be variations between the accounting documents contained in this annual report and those submitted to the electronic Federal Gazette (Bundesanzeiger). In this case, the version submitted to the electronic Federal Gazette shall be binding.

This English version of the annual report is a translation of the original German version; in the event of variations, the German version shall take precedence over the English translation.

**H&R AG**

Neuenkirchener Straße 8  
48499 Salzbergen  
Germany

Phone: +49 (0)59 76-9 45-0  
Fax: +49 (0)59 76-9 45-308

Email: [info@hur.com](mailto:info@hur.com)  
Website: [www.hur.com](http://www.hur.com)